

Ceiling Concealed Split Systems

Models:

MCC / M5CC 010C/CR
 MCC / M5CC 015C/CR
 MCC / M5CC 020C/CR
 MCC / M5CC 025C/CR
 MCC / M5CC 028C/CR
 MCC 030C/CR
 MCC / M5CC 038C/CR
 MCC 040C/CR
 MCC / M5CC 050C/CR
 MCC / M5CC 060C/CR

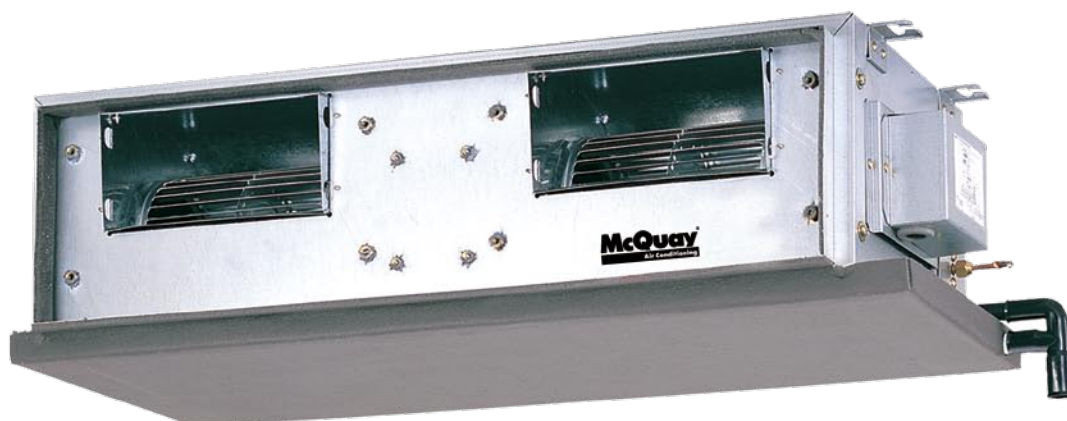

Большая библиотека технической документации

<https://splitsystema48.ru/instrukcii-po-ekspluatcii-kondicionerov.html>

каталоги, инструкции, сервисные мануалы, схемы.

Table of Contents

Nomenclature	1
- Product Line Up	
Features	8
Application Information	9
- Operating Range	
- Refrigerant Circuit Diagram	
- Chiller Panel Controller	
- Precautions and Installation	
Sound Data	27
Selection Process	34
- Fan Performance Charts	
Engineering and Physical Data	52
- Specifications	
Performance Data	123
Dimensional Data	166
Electrical Data	171
Wiring Diagrams	185
Servicing and Maintenance	212
Troubleshooting	214
Exploded View and Part List	219

This manual supercedes MCC - 2007

Note: Installation and maintenance are to be performed only by qualified personnel who are familiar with local codes and regulations, and experienced with this type of equipment.

Caution: Sharp edges and coil surfaces are a potential injury hazard. Avoid contact with them.

Warning: Moving machinery and electrical power hazards. May cause severe personal injury or death. Disconnect and lock off power before servicing equipment.

"McQuay" is a registered trademark of McQuay International. All rights reserved.

©2007 McQuay International. All rights reserved throughout the world.

Bulletin illustrations cover the general appearance of McQuay International products at the time of publication.

We reserve the right to make change in design and construction at any time without notice.



Nomenclature

Indoor

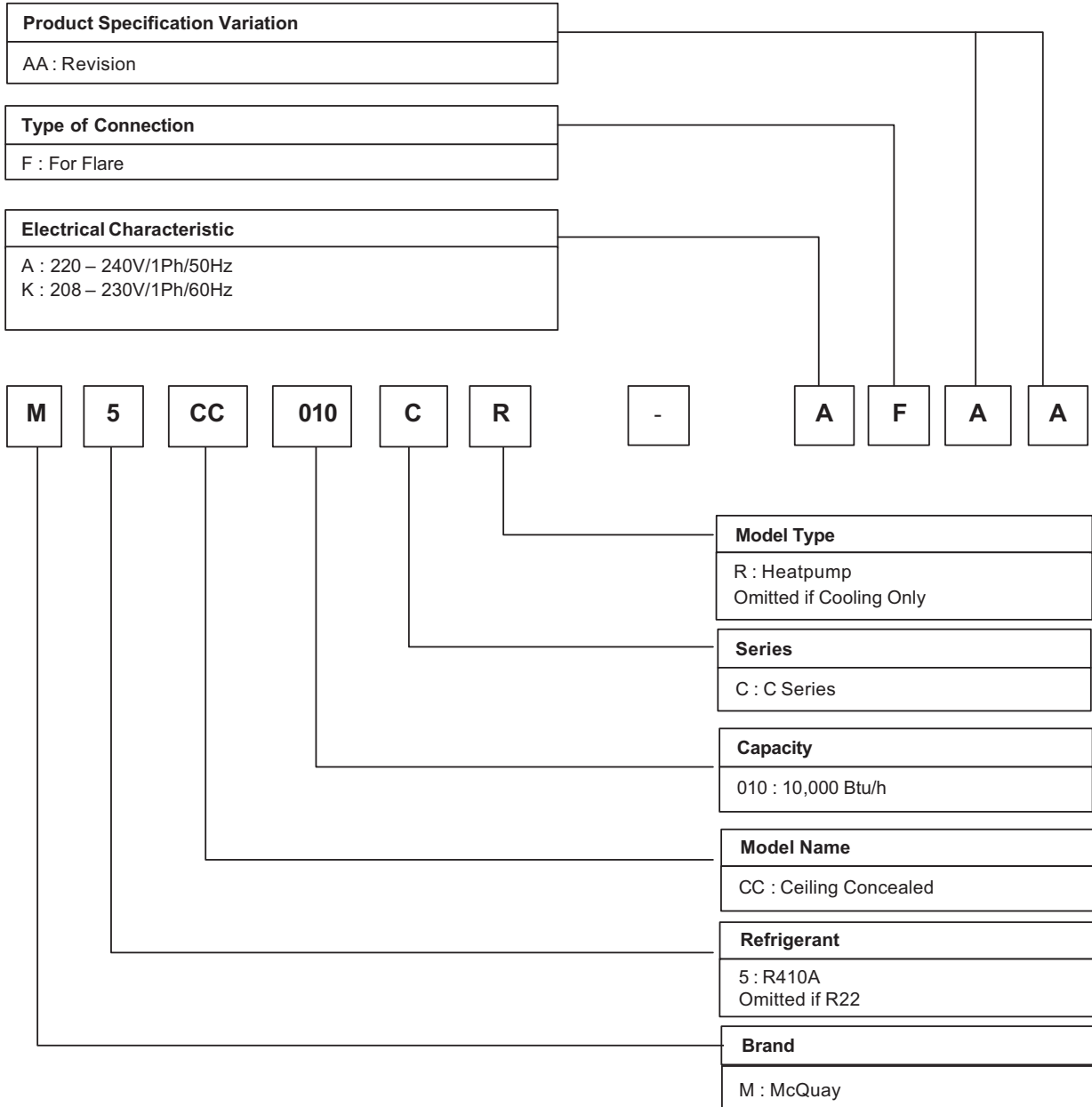

Outdoor

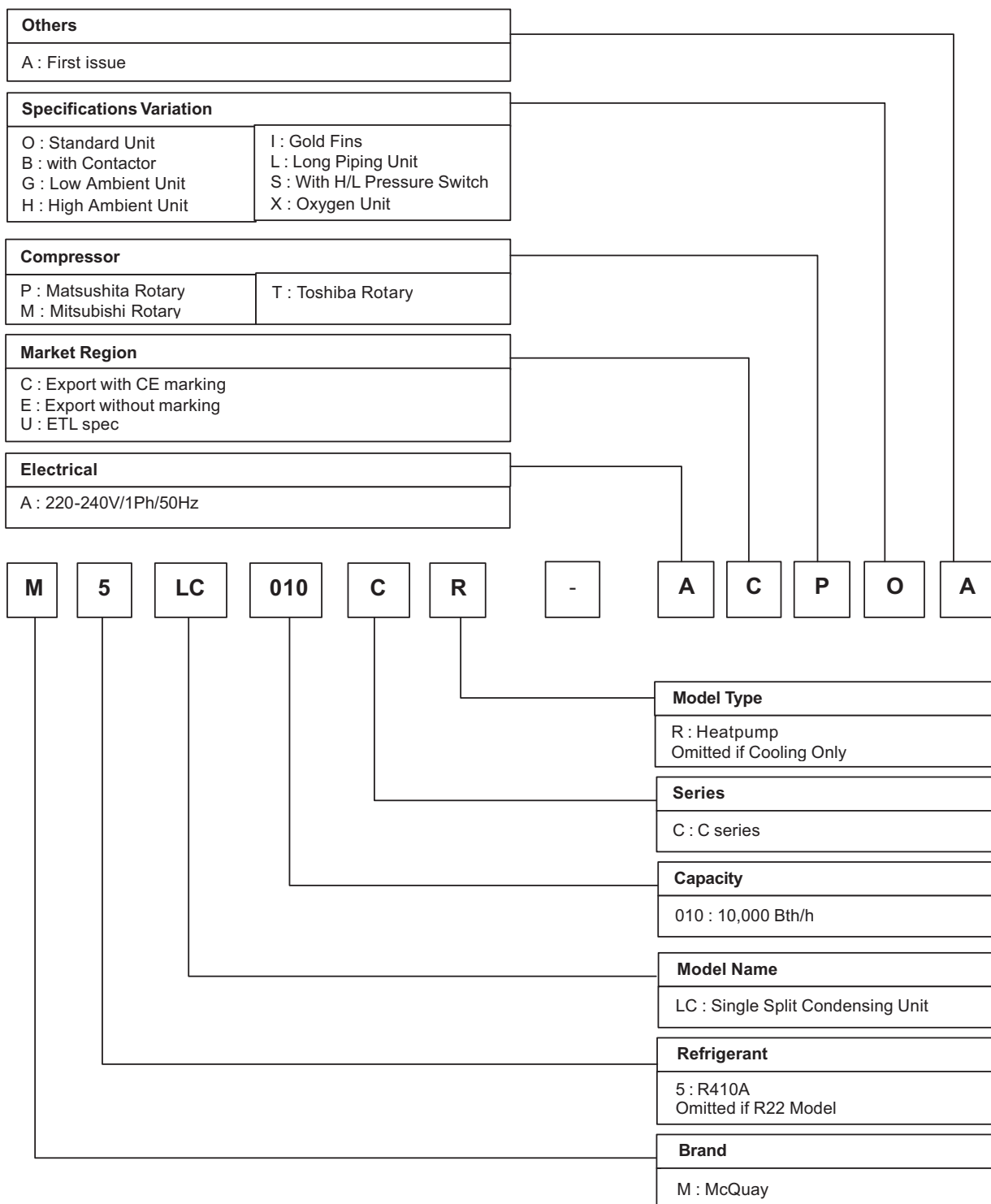

Outdoor

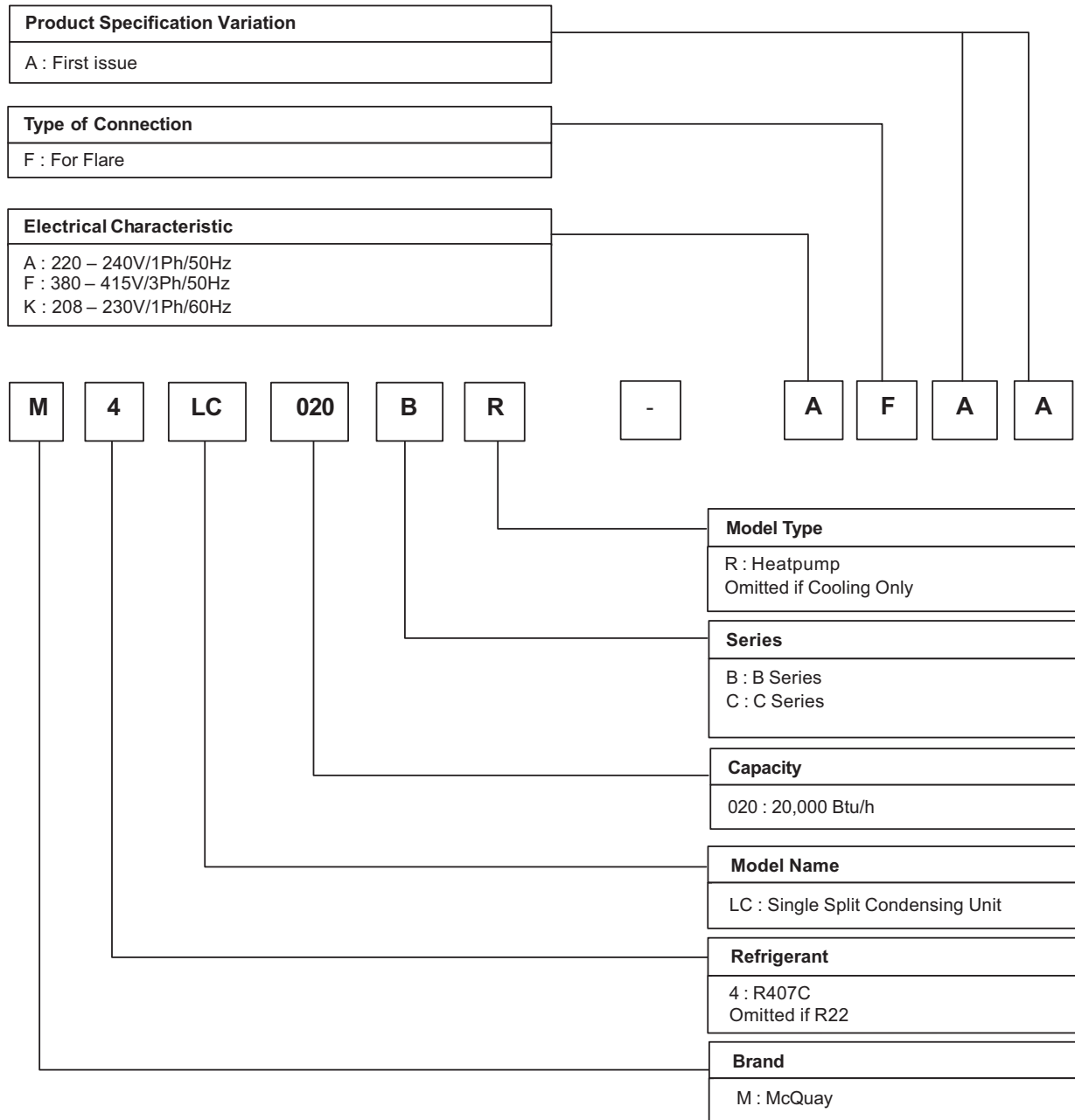

Product Line Up
Indoor Unit
MCC-C Series Product Line Up (R22)

Cooling Only Model

MCC		CLASSIFICATION															
		NONMENCLATURE		Control	Handset		Marking			Refrigerant Control		Filter		Drain Pan		Low Static Model	Built-in Filter Rail
		L2 08A	SLM3	NETWORK 3	CE Mark	W/out Marking	ETL	Cap. Tube	W/out Cap. Tube	Air Filter	W/out Air Filter	Metal Drain Pan	EPS Drain Pan				
Cooling Model	010C	AFDC	X	X		X				X	X			X			
		AFDD	X		X	X				X	X			X			
		AFLB	X	X		X				X	X			X	X		
	015C	AFLC	X	X		X				X	X		X	X			
		AFDC	X	X		X				X	X			X			
		AFDD	X		X	X				X	X			X			
	020C	AFLB	X	X		X				X	X			X	X		
		AFLC	X	X		X				X	X		X	X			
		AFDC	X	X		X				X	X			X			
	025C	AFDD	X		X	X				X	X			X			
		AFLB	X	X		X				X	X			X	X		
		AFLC	X	X		X				X	X		X	X			
	028C	AFAC	X	X		X				X	X					X	
		AFCD	X		X	X				X	X					X	
	030C	AFBC	X	X		X				X	X					X	
		AFCD	X		X	X				X	X					X	
	038C	AFLB	X	X		X				X	X			X	X		
		AFAC	X	X		X				X	X					X	
	040C	AFCD	X		X	X				X	X					X	
		AFLB	X	X		X				X	X			X	X		
	050C	AFBC	X	X		X				X	X				X	X	
		AFCD	X		X	X				X	X				X	X	
	060C	AFLB	X	X		X				X	X				X	X	
		AFCD	X		X	X				X	X				X	X	
	Heat Pump Model	010CR	AFDC	X	X		X				X	X			X		
			AFDD	X		X	X				X	X			X		
			AFLB	X	X		X				X	X			X	X	
		015CR	AFLC	X	X		X				X	X			X	X	
			AFDC	X	X		X				X	X			X		
			AFDD	X		X	X				X	X			X		
		020CR	AFLB	X	X		X				X	X			X	X	
			AFDC	X	X		X				X	X			X		
			AFDD	X		X	X				X	X			X		
		025CR	AFLB	X	X		X				X	X			X	X	
			AFDC	X	X		X				X	X			X		
			AFDD	X		X	X				X	X			X		
		028CR	AFAA	X	X		X				X	X					X
			AFCD	X		X	X				X	X					X
		030CR	AFBB	X	X		X				X	X					X
			AFCD	X		X	X				X	X					X
		38CR	AFLB	X	X		X				X	X			X	X	
			AFAA	X	X		X				X	X					X
040CR		AFCD	X		X	X				X	X					X	
		AFLB	X	X		X				X	X			X	X		
050CR		AFBB	X	X		X				X	X				X	X	
		AFCD	X		X	X				X	X				X	X	
060CR		AFLB	X	X		X				X	X			X	X		
		AFCD	X		X	X				X	X				X	X	

Indoor Unit M5CC-C Series Product Line Up (R410A)

M5CC	NONMENCLATURE	CLASSIFICATION								
		Control		Handset		Marking	Refrigerant Control	With Air Filter	With EPS Drain Pan	Built in Filter Rail
		L2 08A	SLM	Netware III	CE Mark	W/out Cap.Tube				
Cooling Model	010C	AFBA	X	X		X	X	X	X	
	015C	AFBA	X	X		X	X	X	X	
	020C	AFBA	X	X		X	X	X	X	
	025C	AFBA	X	X		X	X	X	X	
	028C	AFBA	X	X		X	X	X		X
	038C	AFAA	X	X		X	X	X		X
	050C	AFAA	X	X		X	X	X		X
060C	AFAA	X	X		X	X	X		X	
Heatpump Model	010CR	AFBA	X	X		X	X	X	X	
	015CR	AFBA	X	X		X	X	X	X	
	020CR	AFBA	X	X		X	X	X	X	
	025CR	AFBA	X	X		X	X	X	X	
	028CR	AFBA	X	X		X	X	X		X
	038CR	AFAA	X	X		X	X	X		X
	050CR	AFAA	X	X		X	X	X		X
060CR	AFAA	X	X		X	X	X		X	

Outdoor Unit MLC-C Product Line Up (R22)

MLC	Nomenclature	Classification														
		Refrigerant Ctrl + Fin			Special		Safety Devices					Grille	Compressor		Marking	
		Cap. Tube	TXV	Gold Fin	High Ambient Kit	Low Ambient Kit	Contact	High Pressure Switch	Low Pressure Switch	Nantong Press. SW	Phase Sequencer	Drain Elbow	Copeland Scroll Comp.	Rotary	CE Marking	ETL
Cooling Model	010C	ACPOB	X											X	X	
		ACPIB	X		X									X	X	
	015C	ACPOD	X											X	X	
		ACPID	X		X									X	X	
	018C	ACPOD	X											X	X	
		ACPBD	X				X							X	X	
		ACPID	X		X									X	X	
	020C	ACPOD	X											X	X	
		ACPID	X		X									X	X	
		ACPBD	X				X							X	X	
	025C	ACPOD	X											X	X	
		ACPBD	X				X							X	X	
		ACPID	X		X									X	X	
	028C	ACHOB												X	X	
		ACHBB					X							X	X	
		ACHIB			X									X	X	
	030C	AFGE					X	X	X	X			X		X	
		AFGG			X		X	X	X	X			X		X	
		FFGE					X	X	X	X	X		X		X	
		FFGG			X		X	X	X	X	X		X		X	
	035C	AFGE					X	X	X	X			X		X	
		AFGG			X		X	X	X	X			X		X	
	040C	AFGE					X	X	X	X			X		X	
		AFGG			X		X	X	X	X			X		X	
FFGE						X	X	X	X	X		X		X		
FFGG				X		X	X	X	X	X		X		X		
050C	FFGN				X	X	X	X	X	X		X		X		
	FFGP				X	X	X	X	X	X		X		X		
	FFGQ			X	X	X	X	X	X	X		X		X		
	FFGT			X	X	X	X	X	X	X		X		X		
061C	FFFE					X	X	X	X	X		X		X		
	FFFG			X		X	X	X	X	X		X		X		
Heat Pump Model	010CR	ACPOB	X								X		X	X		
		ACPIB	X		X						X		X	X		
	015CR	ACPOA	X									X		X	X	
		ACPIA	X		X							X		X	X	
	018CR	ACPOD	X									X		X	X	
		ACPID	X		X							X		X	X	
	020CR	ACPOD	X									X		X	X	
		ACPID	X		X							X		X	X	
	025CR	ACPOD	X									X		X	X	
		ACPID	X		X							X		X	X	
	028CR	ACHOB	X									X		X	X	
		ACHIB	X		X							X		X	X	
	030CR	AFFB	X	X			X	X		X		X	X		X	
		AFFD	X	X	X		X	X		X		X	X		X	
		FFFB	X	X			X	X		X	X	X	X		X	
		FFFD	X	X	X		X	X		X	X	X	X		X	
	035CR	AFFB	X	X			X	X				X	X		X	
		AFFD	X	X	X		X	X				X	X		X	
	040CR	AFFB	X	X			X	X		X		X	X		X	
		AFFD	X	X	X		X	X		X		X	X		X	
		FFFB	X	X			X	X		X	X	X	X		X	
		FFFD	X	X	X		X	X		X	X	X	X		X	
	050CR	FFFF	X	X			X	X		X	X	X	X		X	
		FFFG	X	X	X		X	X		X	X	X	X		X	
061CR	FFFB	X				X	X		X	X	X	X		X		
	FFFD	X		X		X	X		X	X	X	X		X		

Outdoor Unit

M5LC-C SERIES PRODUCT LINE UP

M5LC	Nomenclature	Classification														
		Refrigerant Ctrl + Fin			Special		Safety Devices				Grille	Compressor		Marking		
		Cap. Tube	TXV	Gold Fin	High Ambient Kit	Low Ambient Kit	Contact	High Pressure Switch	Low Pressure Switch	Nantong Press. SW	Phase Sequencer	Drain Elbow	Copeland Scroll Comp.	Rotary	CE Marking	ETL
Cooling Model	010C	ACPOB	X										X	X		
		ACPIB	X	X									X	X		
	015C	ACPIC	X	X									X	X		
		ACPOC	X										X	X		
	020C	ACPIC	X	X									X	X		
		ACPOC	X										X	X		
		FCPOC	X				X				X		X	X		
	025C	ACPIC	X	X									X	X		
		ACPOC	X										X	X		
		FCPOC	X				X				X		X	X		
	028C	ACPOA	X										X	X		
		ACPIA	X	X									X	X		
		FCPOA	X				X				X		X	X		
	035C	ACCOB	X				X	X	X				X		X	
		ACCGB	X	X			X	X	X				X		X	
		FCCOB	X				X	X	X	X	X		X		X	
		FCCGB	X	X			X	X	X	X	X		X		X	
	040C	ACCOB	X				X	X	X				X		X	
		FCCOB	X				X	X	X	X	X		X		X	
		FCCGB	X	X			X	X	X	X	X		X		X	
ACCGB		X	X			X	X	X				X		X		
050C	FCCOB	X				X	X	X		X		X		X		
	FCCGB	X	X			X	X	X		X		X		X		
061C	FCCOB	X				X	X	X		X		X		X		
	FCCGB	X	X			X	X	X		X		X		X		
Heat Pump Model	010CR	ACPOB	X								X		X	X		
		ACPIB	X	X								X		X	X	
	015CR	ACPOC	X									X		X	X	
		ACPIC	X									X		X	X	
	020CR	ACPIC	X	X								X		X	X	
		ACPOC	X									X		X	X	
		FCPOC	X				X				X		X		X	
	025CR	ACPIC	X	X								X		X	X	
		ACPOC	X									X		X	X	
		FCPOC	X				X				X		X		X	
	028CR	ACPOA	X									X		X	X	
		ACPIA	X	X								X		X	X	
		FCPOA	X				X				X		X		X	
	035CR	ACCOB	X				X	X	X			X	X		X	
		ACCGB	X	X			X	X	X			X	X		X	
		FCCOB	X				X	X	X	X	X		X		X	
		FCCGB	X	X			X	X	X	X	X		X		X	
	040CR	ACCOB	X				X	X	X			X	X		X	
		ACCGB	X	X			X	X	X			X	X		X	
		FCCOB	X				X	X	X	X	X		X		X	
FCCGB		X	X			X	X	X	X	X		X		X		
050CR	FCCOB	X				X	X	X		X		X		X		
	FCCGB	X	X			X	X	X		X		X		X		
061CR	FCCOB	X				X	X	X		X		X		X		
	FCCGB	X	X			X	X	X		X		X		X		

Features

Space Saving, Elegance and Prestige

The unit is installed above the ceiling with only the supply and return air grille exposed to view. This ceiling concealed type of design has made it an “Evergreen” model without sacrificing the precious floor space.

The air-conditioned space will appear as elegant and prestigious as centralized air-conditioned area but with only a fraction of the cost. This model is ideal for small offices, hotel rooms, hospitals and restaurant applications.

Double Protection Drainage System

High humidity inside the ceiling area is always the main cause of water leaking. By introducing “Built In” double drain pans solution, i.e. primary drain pan and secondary drain pan, water leaking will not be a problem anymore. The high quality Polystyrene (PS) primary drain pan come with a layer of thermal forming High Impact Polystyrene (HIPS) coating.

The primary drain pan is specially designed, with mould in gradient, for better condensate water drainage. Furthermore, the drain pan is made of PS, which is a very good insulation material to prevent sweating. The secondary drain pan will act as a drip pan to block any water that might be dripped down thus offering an additional protection to the ceiling. In such a case, additional drain pan will not be necessary during installation which means more cost saving. A drain socket is supplied to connect both drain pans to the drainage pipe.

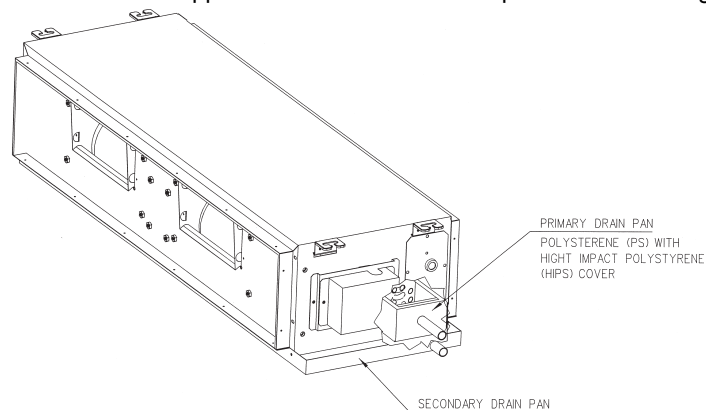

Easy and Flexible Installation

The physical height of the unit is only 261mm / 378mm, it is therefore offering greatest flexibility in selecting installation location.

With its special designed installation accessories, the installation job become easy and better air distribution can be achieved without extra spending on duct works.

ROOM LAYOUT 1

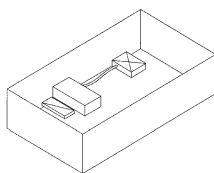

ROOM LAYOUT 2

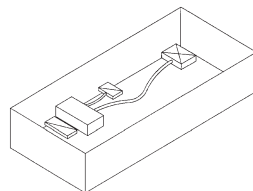

ROOM LAYOUT 3

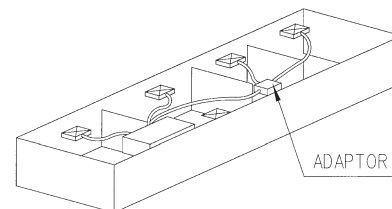

Easy Maintenance

The simple design concept has a friendly maintenance and servicing in mind. Just loosening a few screws, remove secondary drain pan and drain guide, you can access to all the internal parts from the bottom of the unit. No water will splash down when removing the secondary drain pan makes the servicing work never easier before.

Medium Static Pressure with a Low Noise Level

This new series has a static pressure between 0 to 15 mmAq depend on duct work installation. The casing is well insulated internally to reduce the noise level.

Application Information

Ensure the operating temperature is in allowable range.

Cooling only

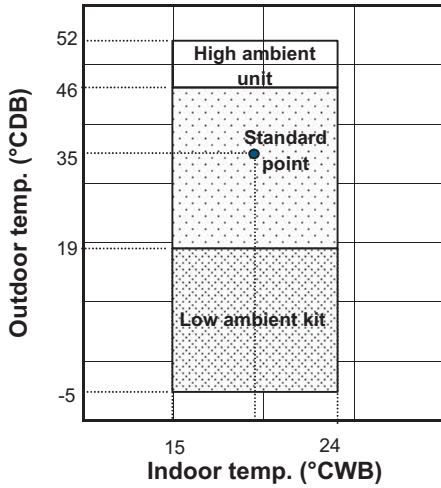

Caution :

The use of your air conditioner outside the range of working temperature and humidity can result in serious failure.

Heat pump

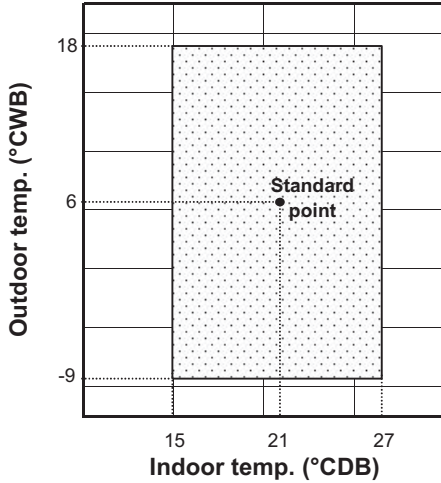

Heating

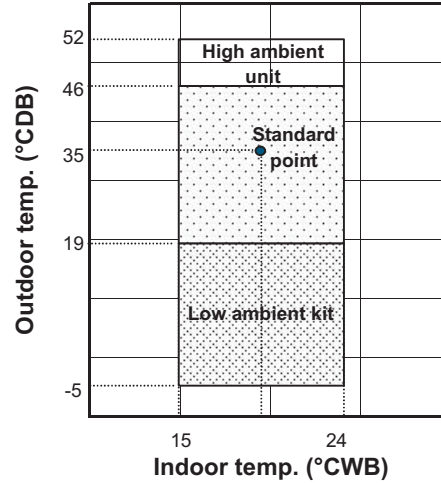

Cooling



Note :

-  Standard operating range.
-  With High ambient unit. (Optional item)
Please refer to local dealer for unit of this specification.
-  With Low ambient kit. (Optional item)
Please refer to local dealer for unit of this specification.

Refrigerant Circuit Diagrams

Model: MCC 010 / 015C – MLC 010 / 015C M5CC 010 / 015C – M5LC 010 / 015C
MCC 020C – MLC 018 / 020C M5CC 020C – M5LC 020C
M5CC 025C – M5LC 025C

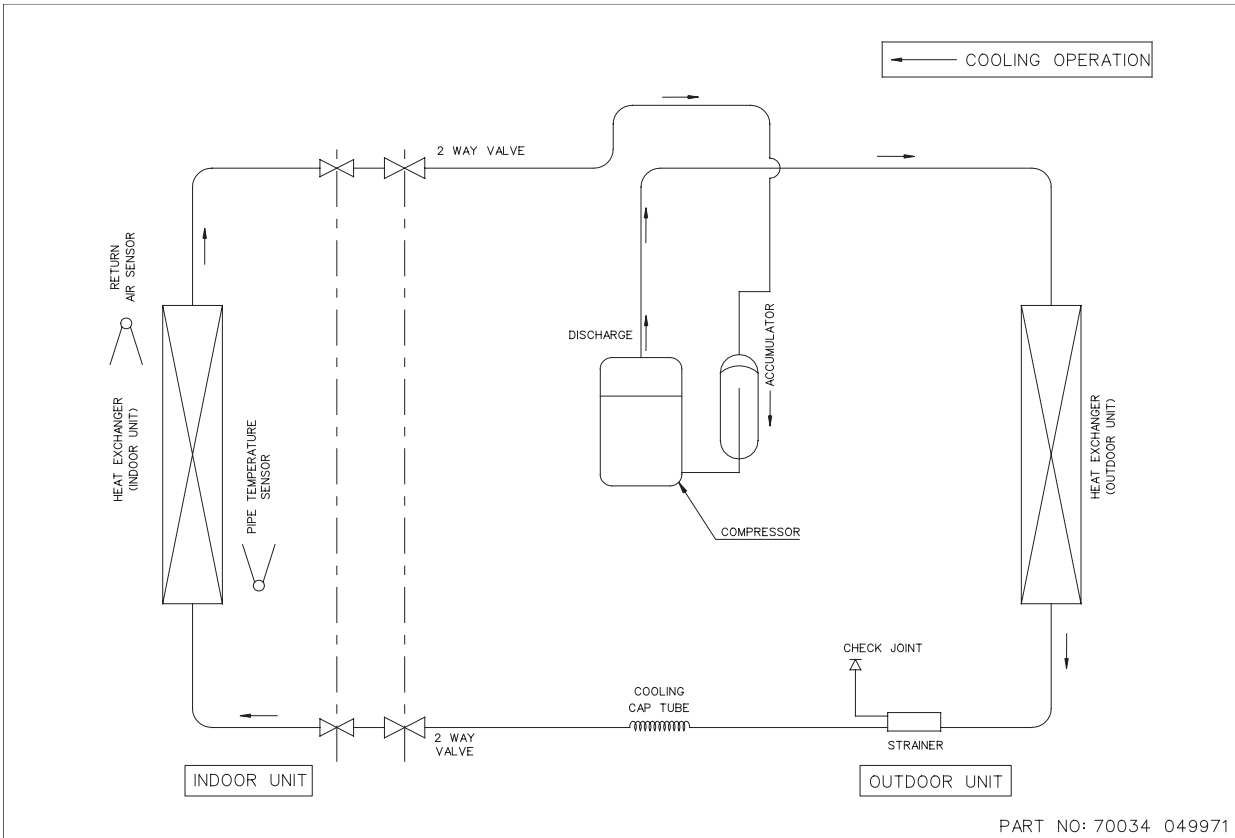

Model : MCC 025C – MLC 025C
M5CC 028C – M5LC 028C

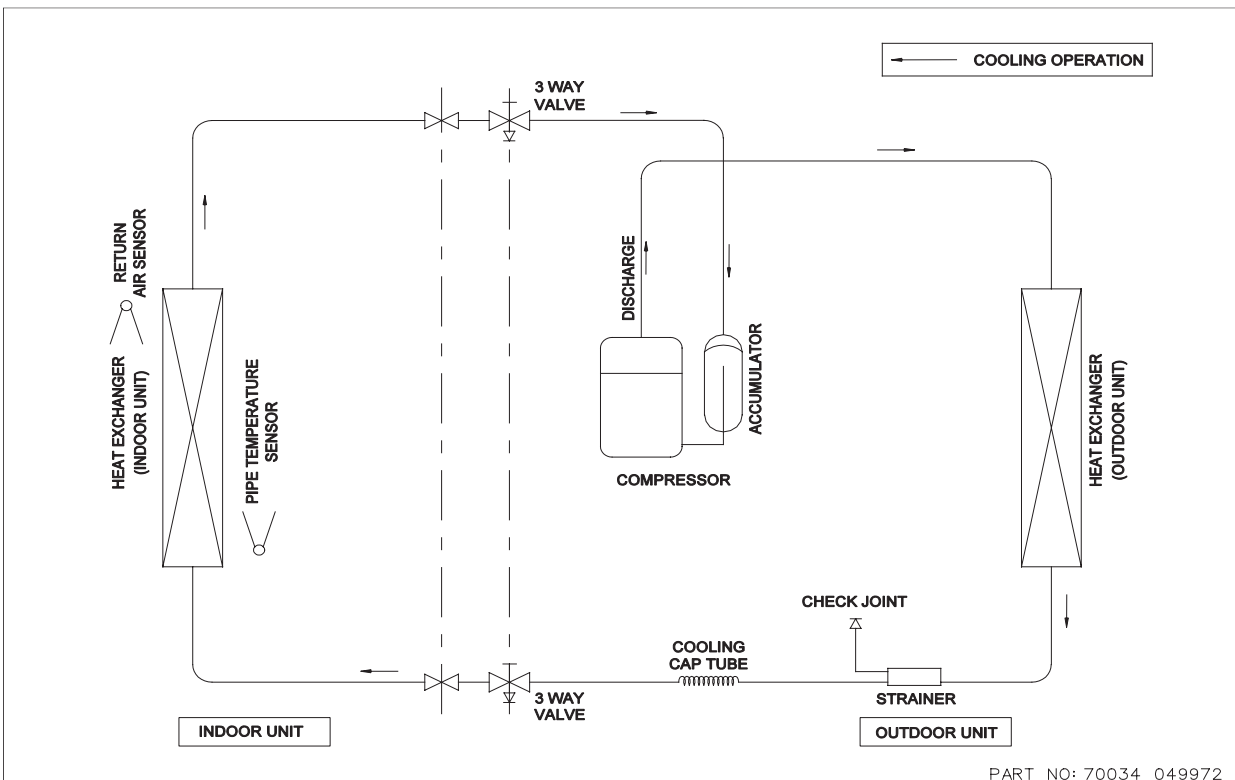

**Model : MCC 028C – MLC 028C
MCC 030C – MLC 028C**

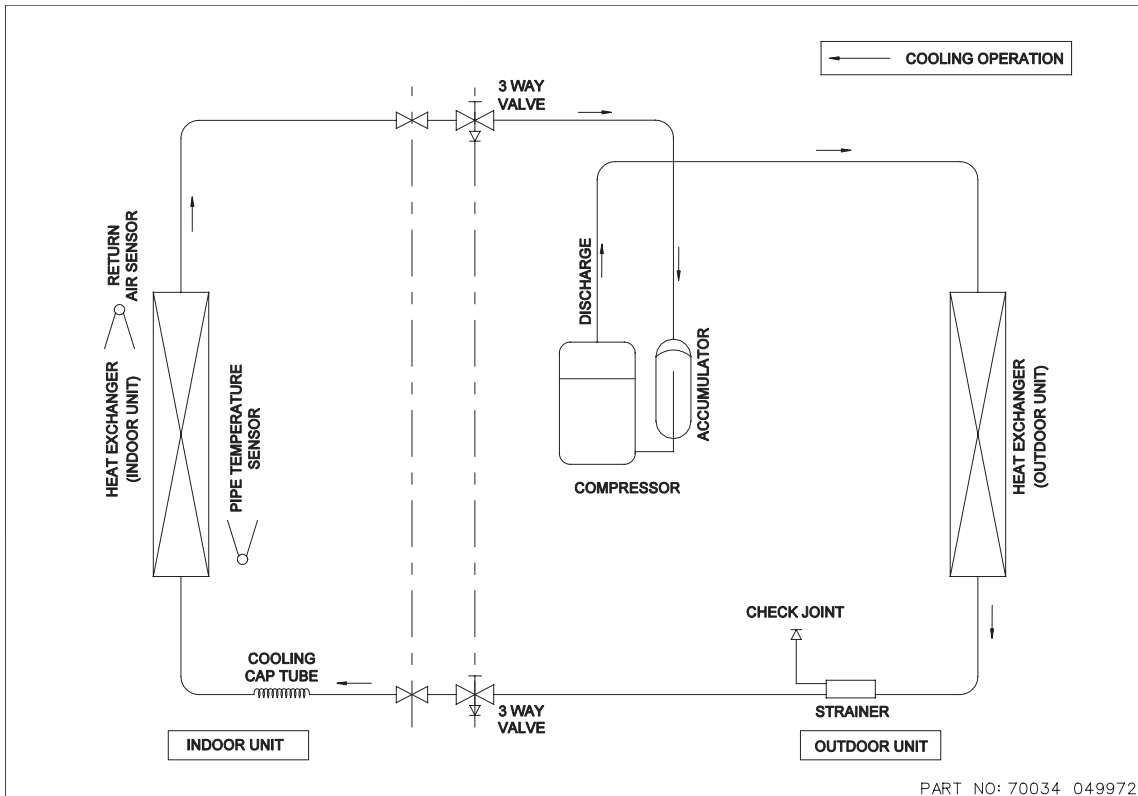

**Model : MCC 028C – MLC 030C MCC 050C – MLC 050C
MCC 060C – MLC 061C
MCC 038 / 040C – MLC 035 / 040C**

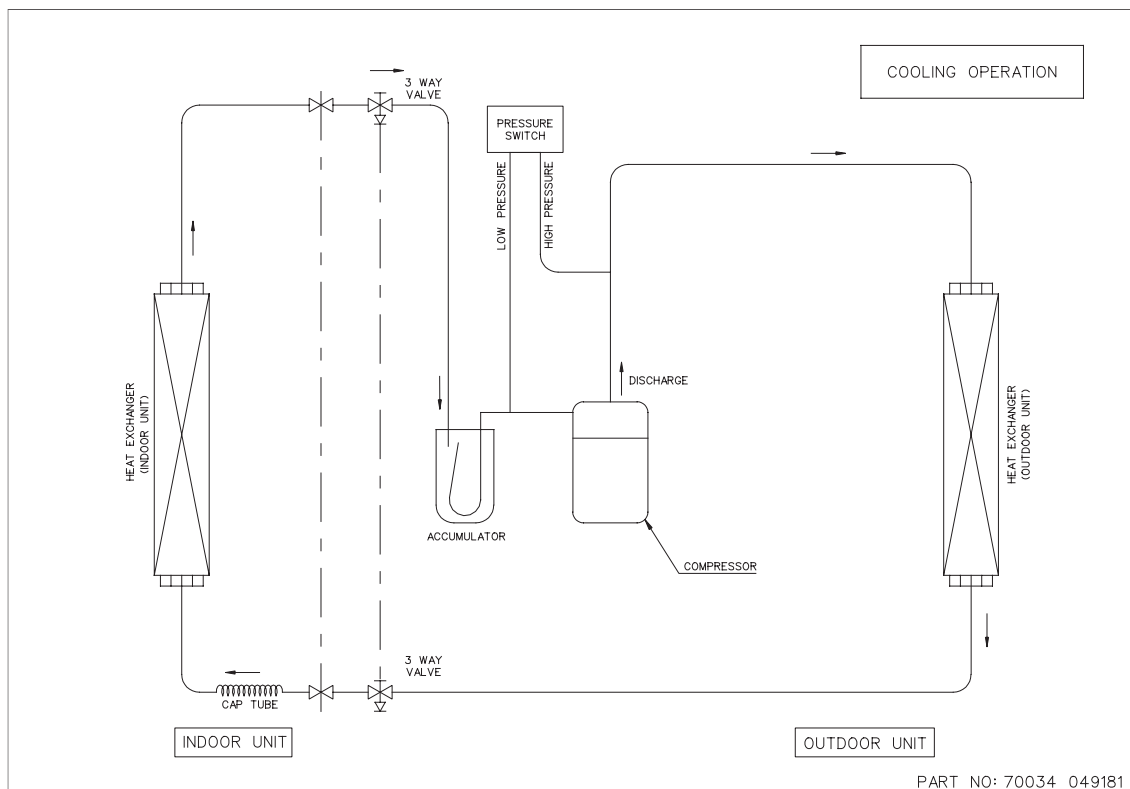

Model : M5CC 038C - M5LC 035C
M5CC 040C - M5LC 040C

M5CC 050C - M5LC 050C
M5CC 060C - M5LC 061C

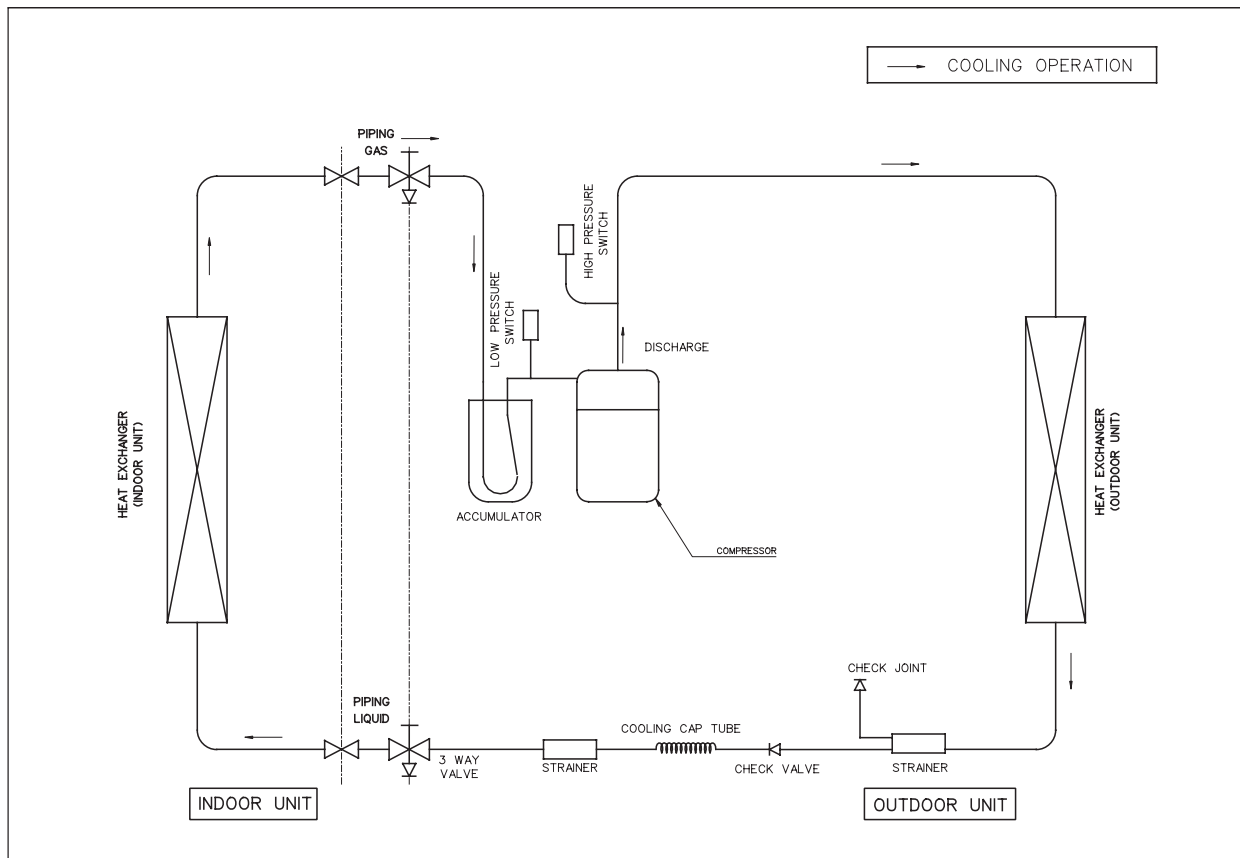

Model : MCC / M5CC 010CR – MLC / M5LC 010CR

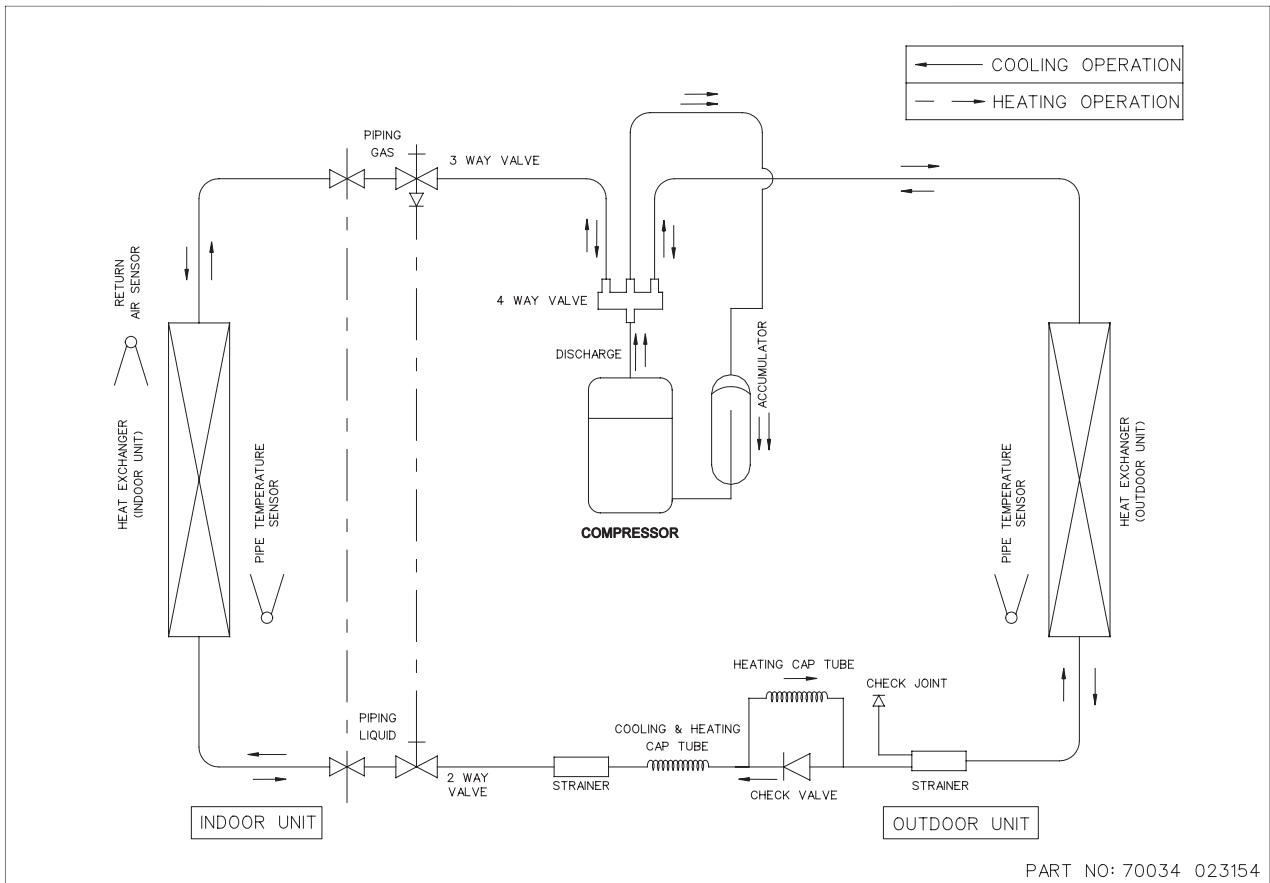

Model : MCC / M5CC 015CR – MLC / M5LC 015CR

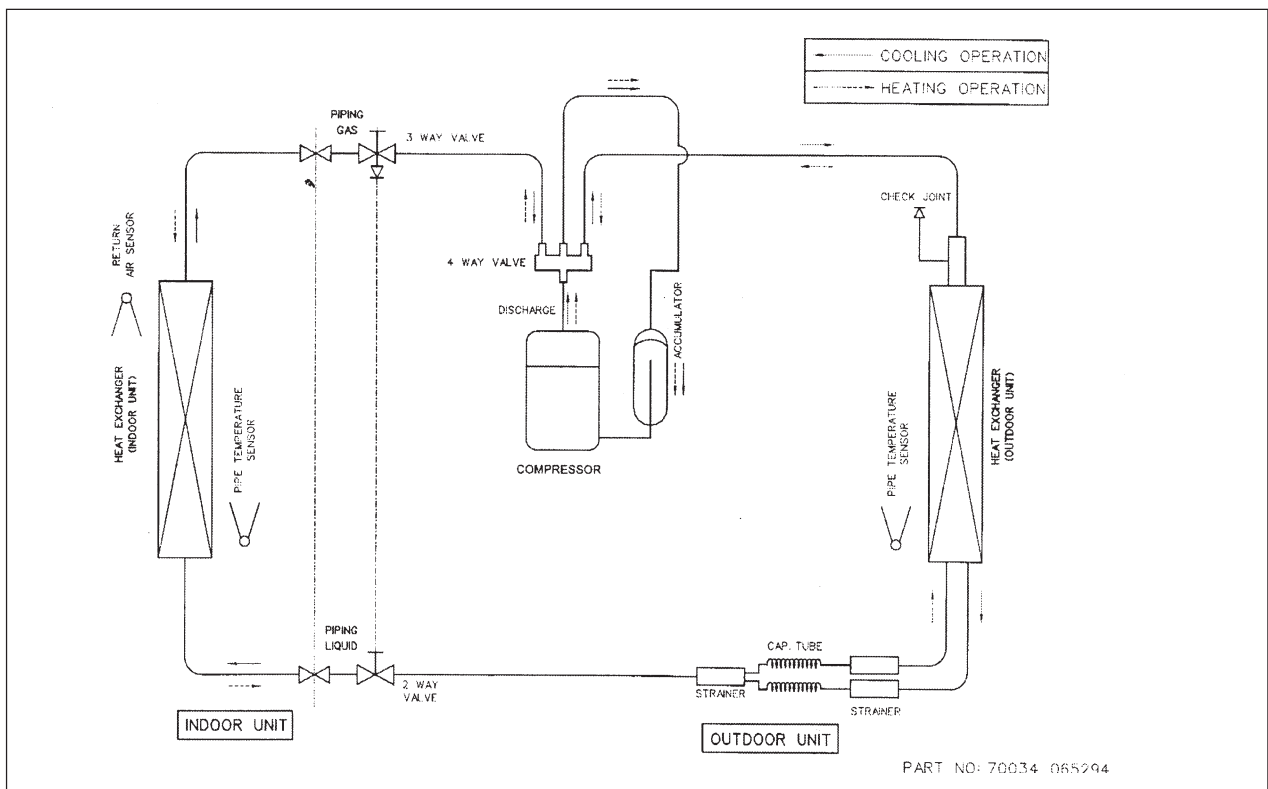

**Model : MCC 020CR – MLC 018 / 020CR
M5CC 020CR – M5LC 025CR
M5CC 025CR - M5LC 025CR**

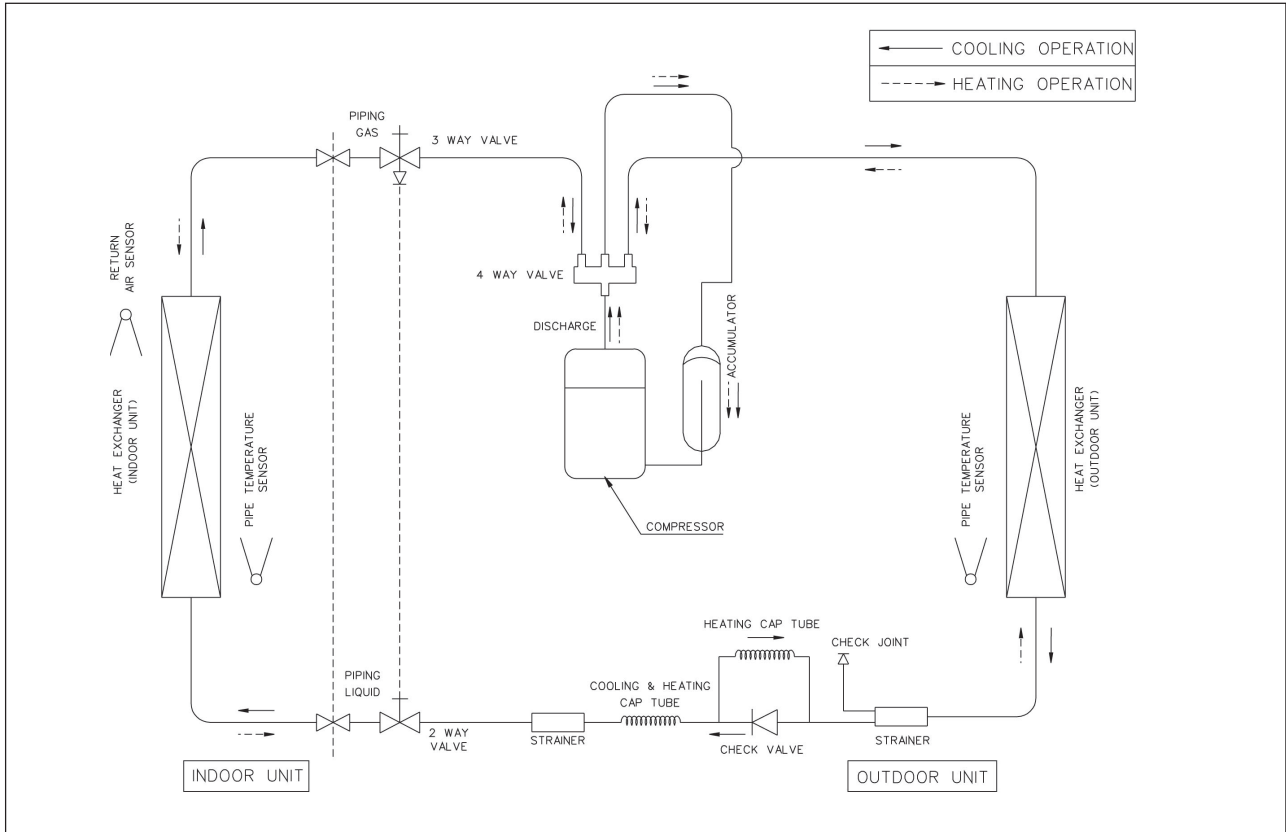

**Model : MCC 025CR – MLC 025CR
MCC 028 / 030CR – MLC 028CR**

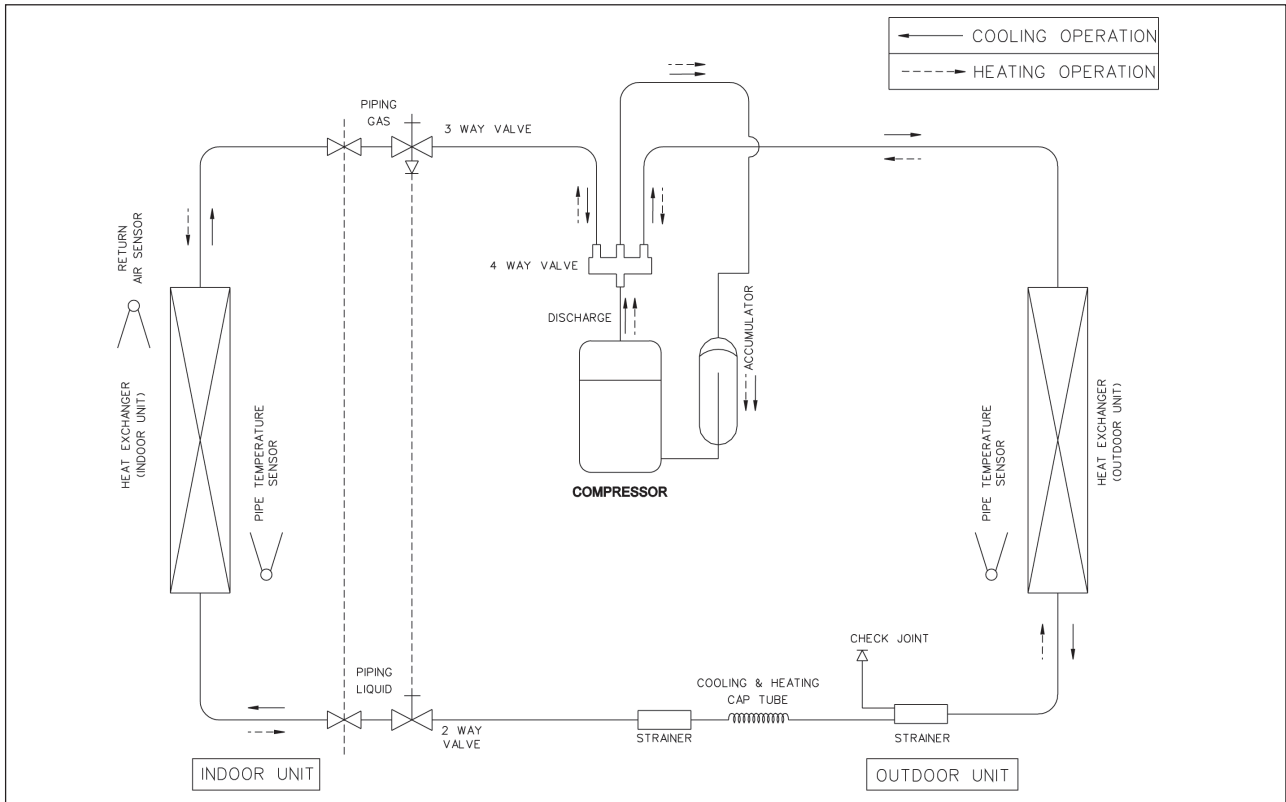

Model : M5CC 028CR – M5LC 028CR

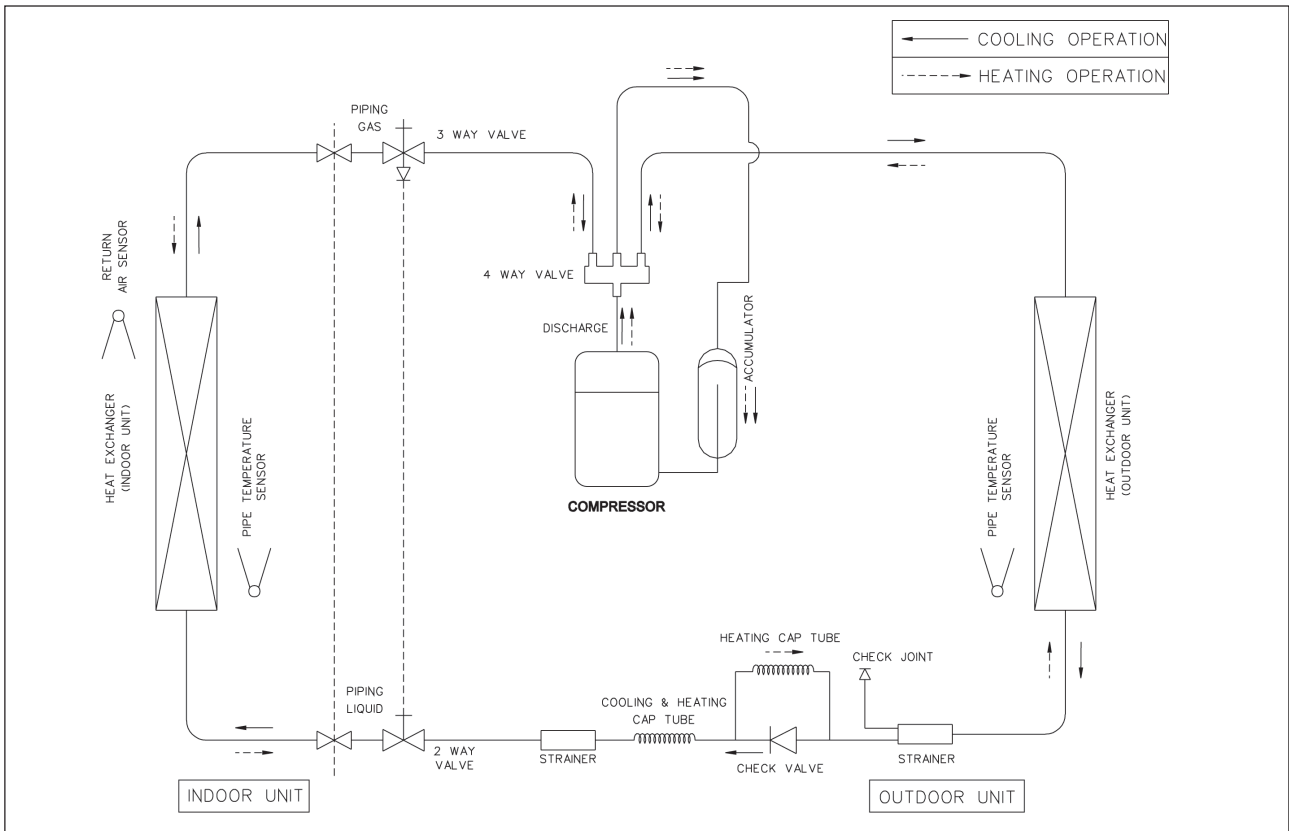

**Model : MCC 028 / 030CR – MLC 030CR
MCC 038 / 040CR – MLC 035 / 040CR**

MCC 050CR – MLC 050CR

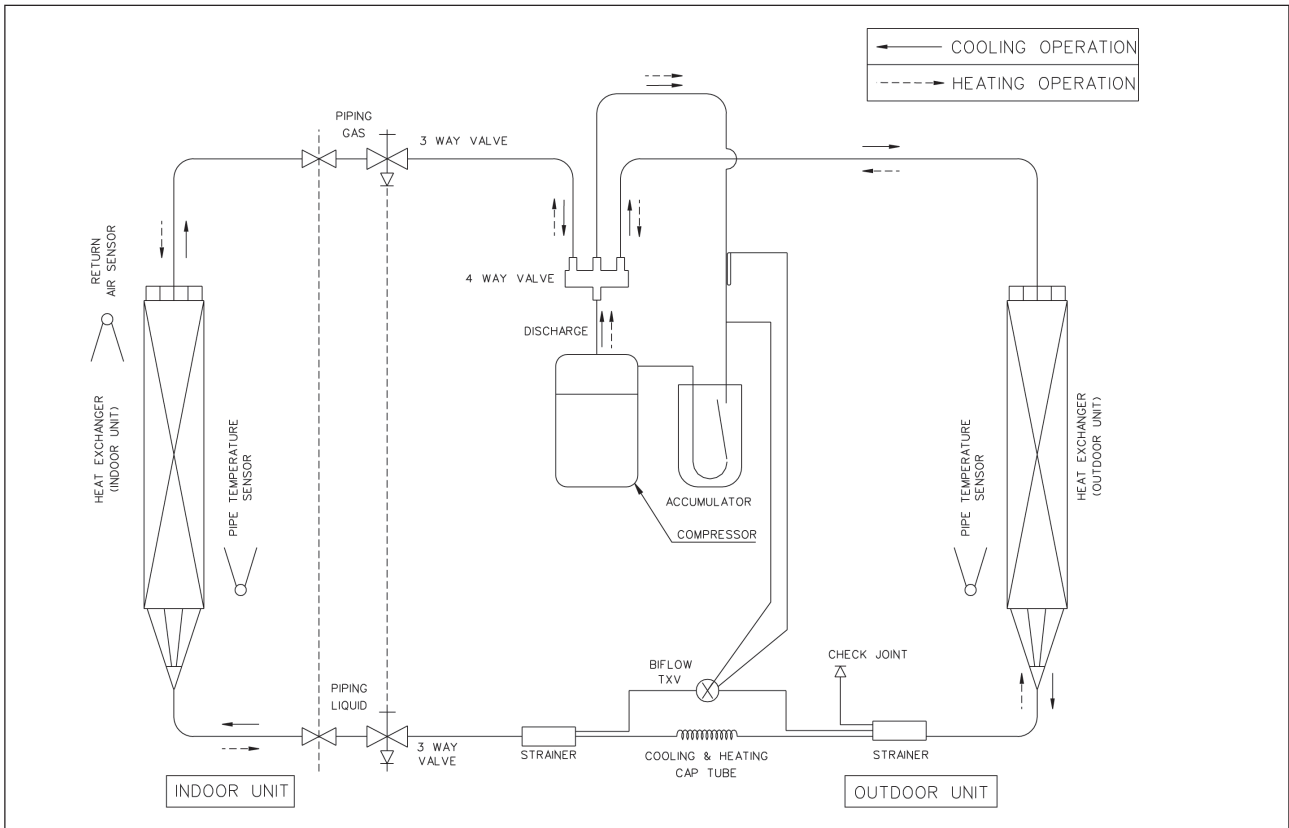

Model : MCC 060CR – MLC 061CR

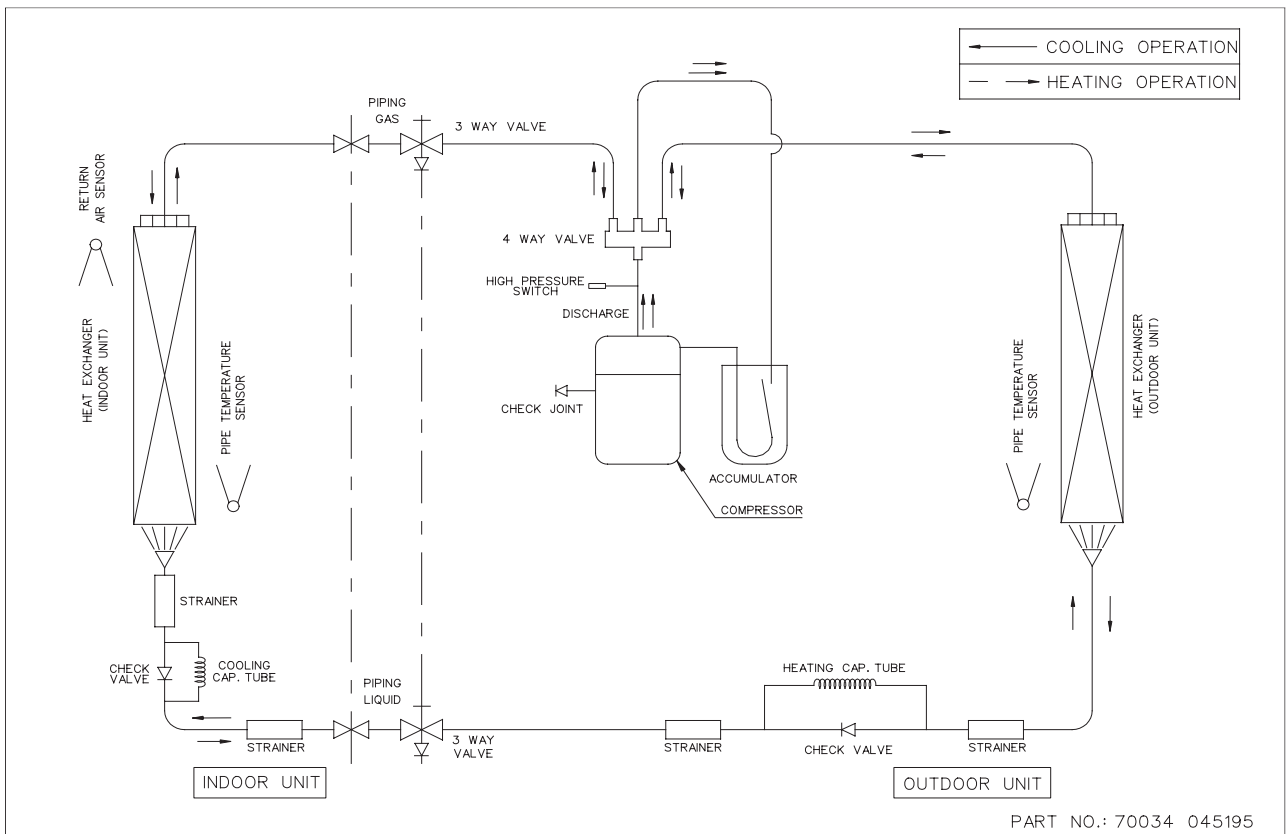

PART NO.: 70034 045195

Model : M5CC 028CR - M5LC 035CR
M5CC 038CR - M5LC 040CR

M5CC 050CR - M5LC 050CR
M5CC 060CR - M5LC 061CR

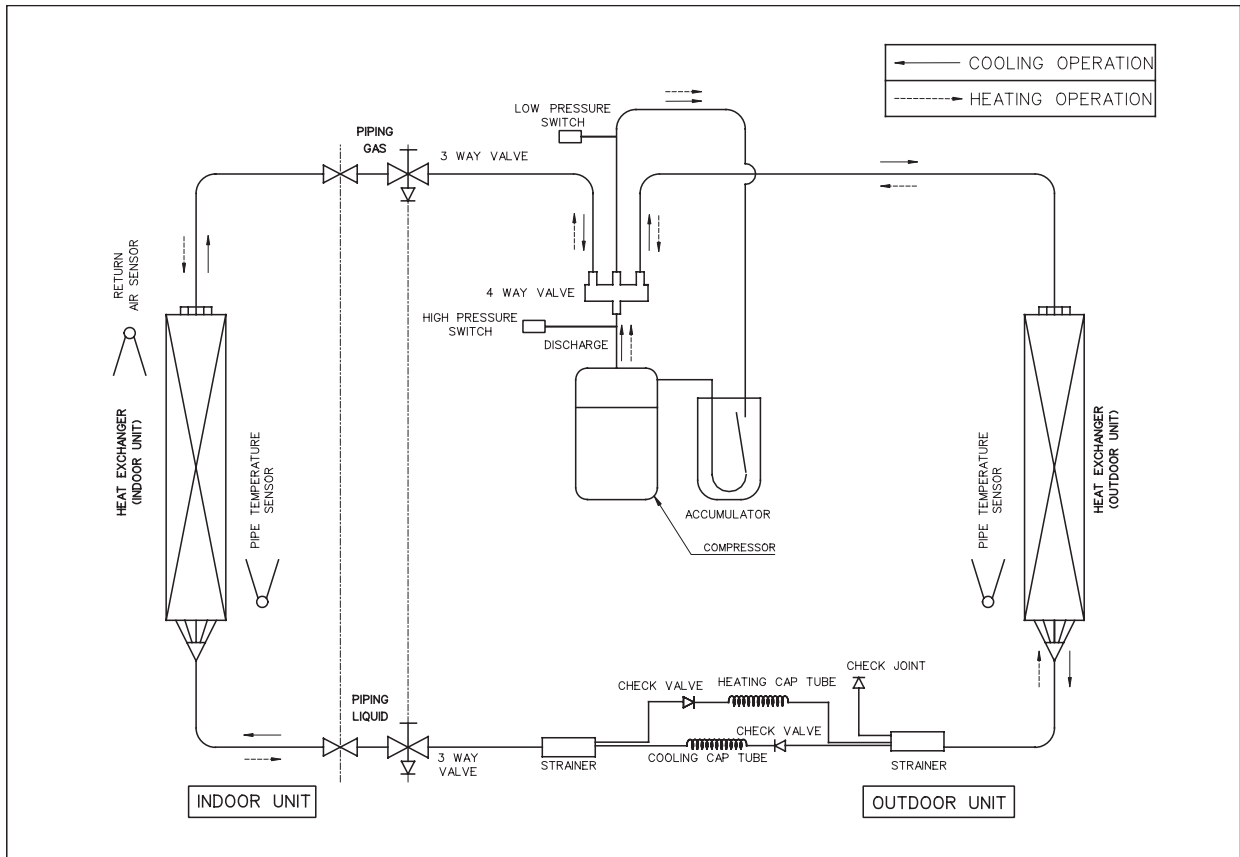

Controllers

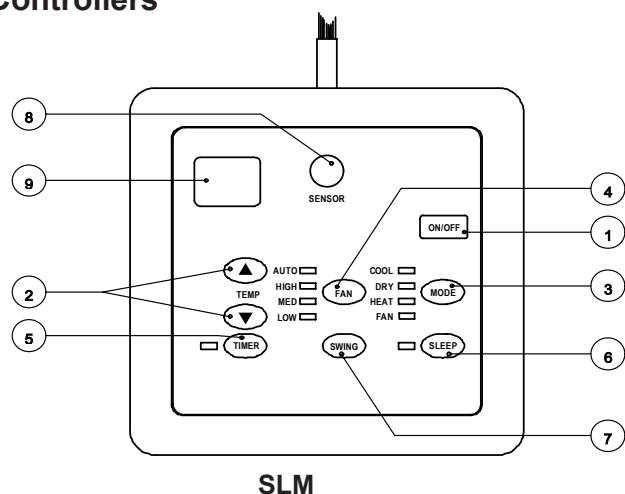

SLM

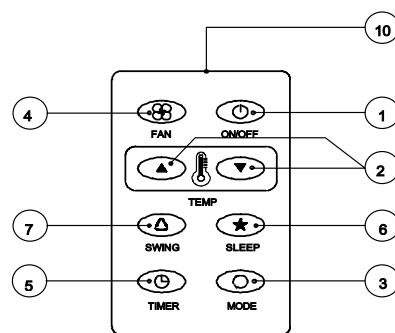

AC-5300 (OPTIONAL)

1. "ON/OFF" switch

- Press to start the air conditioner unit.
- Press again to stop the unit.

2. Temperature setting

- Set the desired room temperature.
- Press button to increase or decrease the set temperature. Setting range are between 16°C to 30°C (60°F to 80°F).

3. Operation Modes

- Press the "mode" button for select the type of operating mode.
- Cooling Only :
COOL, DRY, FAN
- Heat Pump :
AUTO, COOL, DRY, HEAT, FAN
(AUTO mode is represented by both COOL and HEAT LED light on)

4. Fan Speed selection.

- Press the button until the desired fan speed is achieved.

5. Timer.

- Press the set button to select the switch timer of the air conditioner unit (the setting range is between 1 to 10 hours).

6. "Sleep mode"

- Press button to activate the sleep function
This function can only be activated under "cool" or heating mode operation. When it is activated under "cool" mode operation, the set temperature will increase 0.5°C after 30 minutes, 1°C after 1 hour and 2°C after 2 hours
If it is activated under "HEAT" mode operation, the set temperature will be decreased 0.5°C after 30 minutes, 1°C after 1 hour and 2°C after 2 hours.

7. Air Swing

- Press button to activate the automatic air swing function.

8. Sensor

- Infra red sensor to receive signals from wireless controller.

9. LED Display

- To display the set temperature (in °C) and timer delay setting (in hours).

10. Transmission source

- To transmit signals to the air conditioner.

Operating State and Fault Table

Cooling / Heatpump Model (Universal Board)

Error Code at 7 Segment Display	Operation / Faulty Indication
Blink E1	Room sensor contact loose / short
Blink E2	Indoor coil sensor contact loose
Blink E3	Outdoor coil sensor contact loose
Blink E4	Compressor overload / Indoor coil sensor short / Outdoor coil sensor short
Blink E5	Gas leak
Blink E6	N/A
Blink Heat LED	Outdoor defrost (for Heatpump only)

Phase Sequencer

The unit with Scroll Compressor can only rotate in one direction. For this reason, a protective device (phase sequencer) is fitted to prevent incorrect wiring of the electrical phases. When the three phases are not connected correctly, the phase sequencer operates, and the unit will not start. This device is located in the control box of the outdoor unit.

The following table shows the LED indicator light for phase sequencer under normal operation and fault conditions.

	LED_P (Red)	LED_R (Yellow)	LED_S (Yellow)	LED_T (Yellow)
Normal Operation	On	-	-	-
Reverse Phase	Blink	Blink	Blink	Blink
S & T Phase Missing	Blink	-	Blink	Blink
T Phase Missing	Blink	-	-	Blink
S Phase Missing	Blink	-	Blink	-
R Phase Missing	-	-	-	-
Overload	Blink	-	-	-
Sensor Missing	Blink	On	On	On

- Notes:
1. "-" means LED off.
 2. When R phase missing, no LED or buzzer will indicate the error, but relay 71 (Common) and 81 (NO) will cut off.
 3. The unit will check the discharge sensor availability only during power up.
 4. All errors can only recover through **manually reset**.



Caution

Sharp edges and coil surfaces are potential injury hazard. Avoid from contact with them.

(1) Installation of Indoor Unit

Preliminary Survey

- Electrical supply and installation is to confirm to local authority's (e.g. National Electrical Board) codes and regulations.
- Voltage supply fluctuation must not exceed $\pm 10\%$ of rated voltage. Electricity supply lines must be independent of welding transformers which can cause high supply fluctuation.
- Ensure that the location is convenient for wiring, piping and drainage.
- The indoor unit must be installed in such that free from any obstacles in path of cool air discharge and warm air return, and must allow spreading of air throughout the room (near the centre of the room).
- Clearance must be provided for the indoor unit from the wall and obstacles as shown in the figure.
- Use the hanger supplied with the unit.
- Ensure the support is strong enough to withstand the weight of the unit.
- Use the supplied drain socket to connect the drain pipe (the drain socket is only available for 10C/CR to 25C/CR)

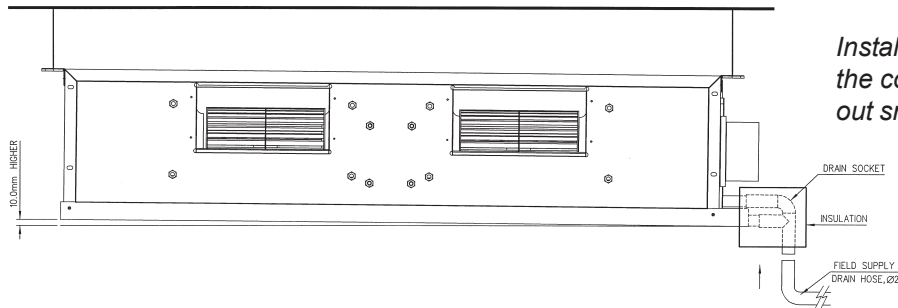

The diagrams below show the screws position for duct work connection.

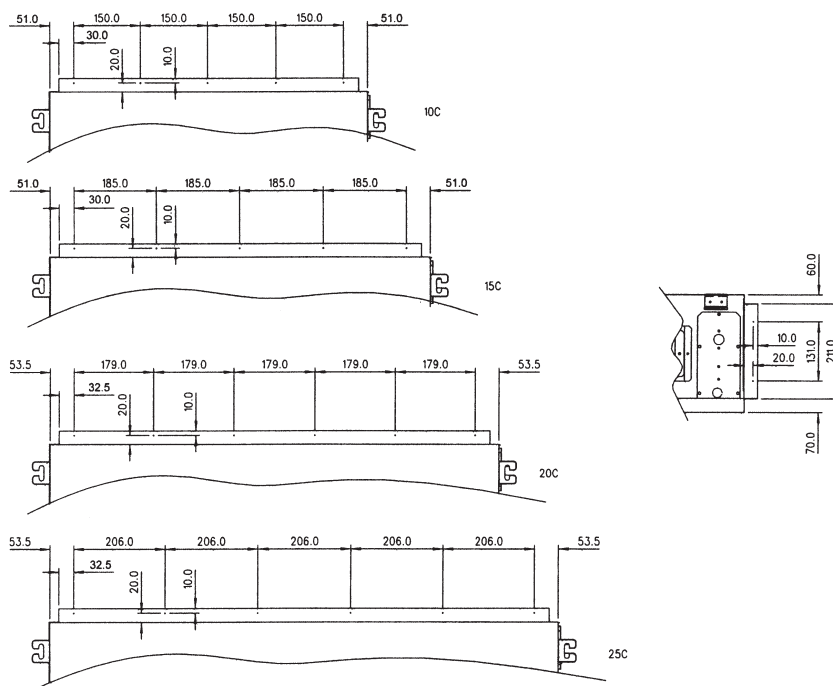

(2) Installation of Outdoor Unit

As condensing temperature rises, evaporating temperature rises and cooling capacity drops. In order to achieve maximum cooling capacity, the location selected for outdoor unit should fulfill the following requirements:

- Install the condensing (outdoor) unit in a way such that hot air distributed by the outdoor condensing unit cannot be drawn in again (as in the case of short circuit of hot discharge air). Allow sufficient space for maintenance around the unit.

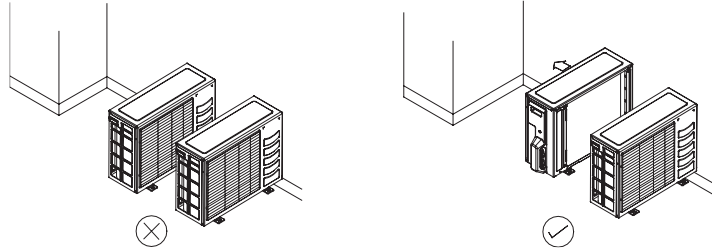

- Ensure that there is no obstruction of air flow into or out of the unit. Remove obstacles which block air intake or discharge.
- The location must be well ventilated, so that the unit can draw in and distribute plenty of air thus lowering the condensing temperature.

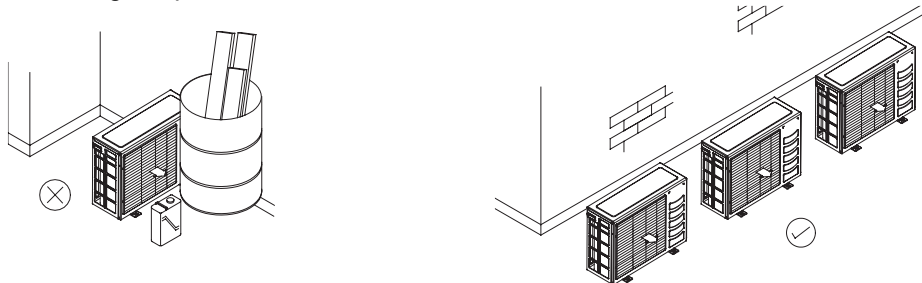

- A place capable of bearing the weight of the outdoor unit and isolating noise and vibration.
- A place protected from direct sunlight. Otherwise use an awning for protection, if necessary.

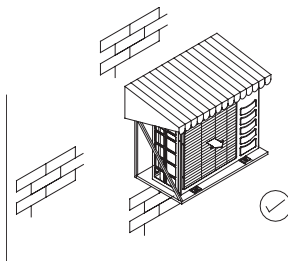

- The location must not be susceptible to dust or oil mist.

Installation Clearance

- Outdoor units must be installed such that there is no short circuit of the hot discharge air or obstruction to smooth air flow. Select the coolest possible place where intake air should not be hotter than the outside temperature (max. 45°C).



All Model	A	B	C	D
Minimum Distance	300 mm	1000 mm	300 mm	500 mm

CAUTION : If the condensing unit is operated in an atmosphere containing oils (including machine oils), salt (coastal area), sulphide gas (near hot spring, oil refinery plant), such substances may lead to failure of the unit.

(3) Refrigerant Piping

Maximum Pipe and Maximum Number of Bends

- When the pipe length becomes too long, both the capacity and reliability drop. As the number of bends increases, system piping resistance to the refrigerant flow increases, thus lowering the cooling capacity, and as the result the front compressor may become defective. Always choose the shortest path and follow the recommendation as tabulated below:

Model	Indoor	010 / 015C/CR	020 / 025C/CR	028 / 030C/CR		038 / 040 / 050C/CR	060C/CR
	Outdoor	010 / 015C/CR	020 / 025C/CR	028C/CR	030C/CR	035 / 040 / 50C/CR	061C/CR
Maximum Length, m		15	15	15	45	45	35
Maximum Elevation, m		8	8	8	25	25	25
Maximum No. of Bends		10	10	10	10	10	10

Piping Sizes (Flare connection type)

Piping sizes are as follows:

R22

Model	MLC 010C/CR	MLC 015C/CR	MLC 018/020C/CR	MLC 025C/CR
Liquid (mm/in)	6.35 / 1/4	6.35 / 1/4	6.35 / 1/4	9.52 / 3/8
Suction (mm/in)	9.52 / 3/8	12.70 / 1/2	15.88 / 5/8	15.88 / 5/8

Model	MLC 028 / 030C/CR	MLC 035 / 040C/CR	MLC 050C/CR	MLC 061C/CR
Liquid (mm/in)	9.52 / 3/8	9.52 / 3/8	9.52 / 3/8	12.70 / 1/2
Suction (mm/in)	15.88 / 5/8	19.05 / 3/4	19.05 / 3/4	19.05 / 3/4

R410A

Model	M5LC 010C/CR	M5LC 015C/CR	M5LC 020C/CR	M5LC 025C/CR
Liquid (mm/in)	6.35 / 1/4	6.35 / 1/4	6.35 / 1/4	6.35 / 1/4
Suction (mm/in)	9.52 / 3/8	12.70 / 1/2	12.70 / 1/2	15.88 / 5/8

Model	M5LC 028 / 035C/CR	M5LC 040C/CR	M5LC 050C/CR	M5LC 061C/CR
Liquid (mm/in)	9.52 / 3/8	9.52 / 3/8	9.52 / 3/8	9.52 / 3/8
Suction (mm/in)	15.88 / 5/8	15.88 / 5/8	15.88 / 5/8	19.05 / 3/4

Piping Connection to The Units

- Align the centre of the piping and tighten the flare nut sufficiently with fingers.
- Finally tighten the flare nut with torque wrench unit the wrench clicks.
- When tightening the flare nut with torque wrench, ensure the direction for tightening follows the arrow on the wrench.

Pipe Size (mm/in)	Torque (Nm)
6.35 (1/4)	18
9.52 (3/8)	42
12.70 (1/2)	55
15.88 (5/8)	65
19.05 (3/4)	78

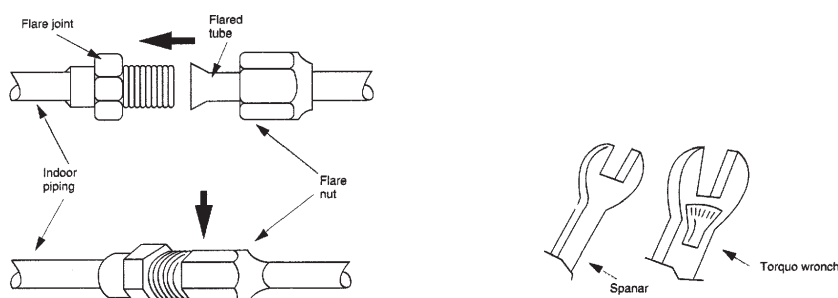

4) Wiring

ELECTRICAL CONNECTIONS

- Wiring regulations on wire diameters differ from country to country. Please refer to your LOCAL ELECTRICAL CODES for field wiring rules. Be sure that installations comply with the rules and regulations.

GENERAL PRECAUTIONS

- Ensure that the rated voltage of the unit corresponds to the name plate before carrying out proper wiring according to the wiring diagram.
- Provide a power outlet to be used exclusively for each unit. A power supply disconnects and a circuit breaker for over-current protection should be provided in the exclusive line.
- The unit must be **GROUND**ED to prevent possible hazards due to insulation failures.
- All wiring must be firmly connected.
- All wiring must not touch the hot refrigerant piping, compressor or any moving parts of fan motors.

(5) Vacuuming and Charging

The pre-charged outdoor unit does not need any vacuuming or charging. However once it is connected, the connecting pipe line and the indoor unit need to be vacuumed before releasing the R22/R407C/R410A from the outdoor unit.

- Open the service port core cap.
- Connect pressure gauge to the service port.
- Connect the line to vacuum pump. Open the charging manifold valve and turn the pump on. Vacuum to -0.1 MPa (-760mmHg) or lower. (Evacuation time varies by the pump but averagely in 1 hour).

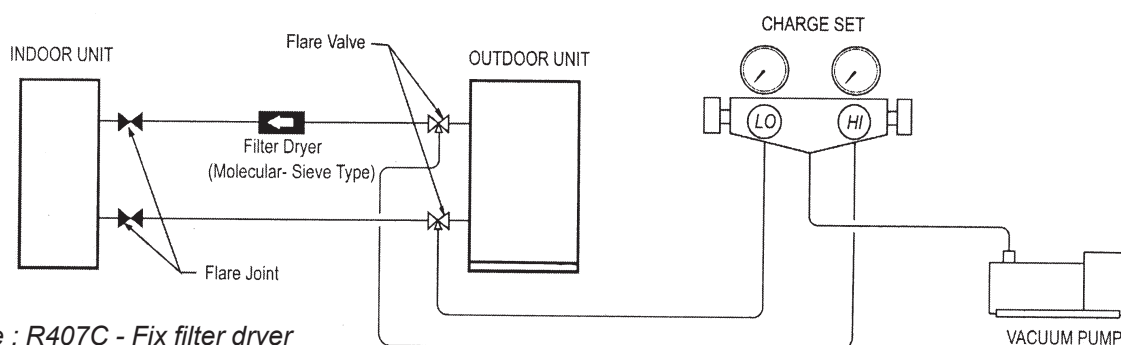

Note : R407C - Fix filter dryer
R22 - Nil
R410A - Nil

- After evacuation, unscrew the spindle (diagram B) for the gas to run to indoor unit.

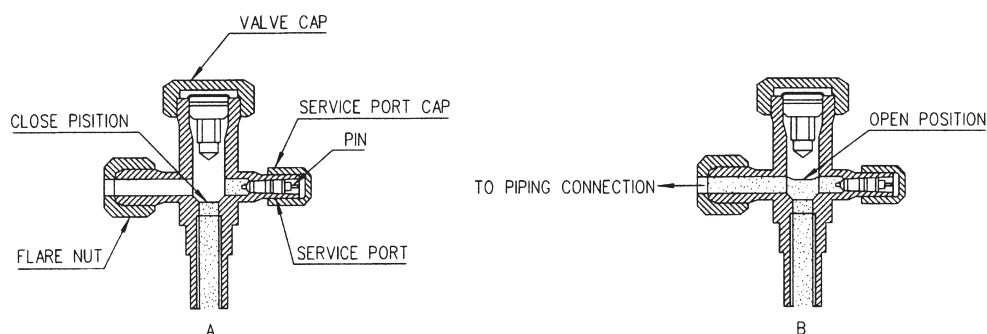

CAUTION FOR R407C / R410A

Do not top-up when servicing leak, as this will reduce the unit performance. Vacuum the unit thoroughly and then charge the unit with fresh R407C according to the amount recommended in the specification.

(6) Additional Charge

- The refrigerant charge has already charged into the outdoor unit. For the piping length of 7.6m, additional refrigerant charge after vacuuming is not necessary.
- When the piping length is more than 7.6m, please use the table below (unit in gram).

R22

Model	10m	12m	15m	25m	35m	45m
010C/CR	38 / 54	69 / 99	-	-	-	-
015C/CR	37 / 55	69 / 100	-	-	-	-
018C/CR	38 / 54	69 / 98	116 / 166	-	-	-
020C/CR	37 / 54	69 / 98	115 / 165	-	-	-
025C/CR	93 / 134	171 / 245	287 / 412	-	-	-
028C/CR	94 / 133	172 / 244	289 / 411	-	-	-
030C/CR	133 / 133	244 / 243	410 / 409	964 / 961	1518 / 1514	2072 / 2067
035C/CR	129 / 134	237 / 246	399 / 413	938 / 972	1476 / 1530	2015 / 2088
040C/CR	133 / 134	244 / 246	410 / 413	964 / 972	1518 / 1530	2072 / 2088
050C/CR	130 / 135	238 / 248	400 / 417	941 / 980	1482 / 1543	2022 / 2106
061C/CR	245 / 255	448 / 468	754 / 786	1773 / 1849	2791 / 2912	-

R410A

Model	10m	12m	15m	25m	35m	45m
010C/CR	23 / 38	43 / 70	-	-	-	-
015C/CR	20 / 40	37 / 74	-	-	-	-
020C/CR	25 / 37	45 / 68	76 / 115	-	-	-
025C/CR	63 / 88	115 / 161	193 / 270	-	-	-
028C/CR	98 / 98	180 / 180	303 / 303	-	-	-
040C/CR	61 / 97	112 / 178	189 / 299	445 / 703	700 / 1107	956 / 1511
050C/CR	50 / 87	92 / 157	155 / 267	363 / 628	572 / 989	781 / 1350
061C/CR	94 / 163	173 / 298	290 / 502	682 / 1179	1075 / 1857	-

The additional refrigerant charge amount recommended is a guideline for longer piping application. The actual charge required may be different from the guideline due to different application and variation in site conditions.

Diagram shows typical charging method:

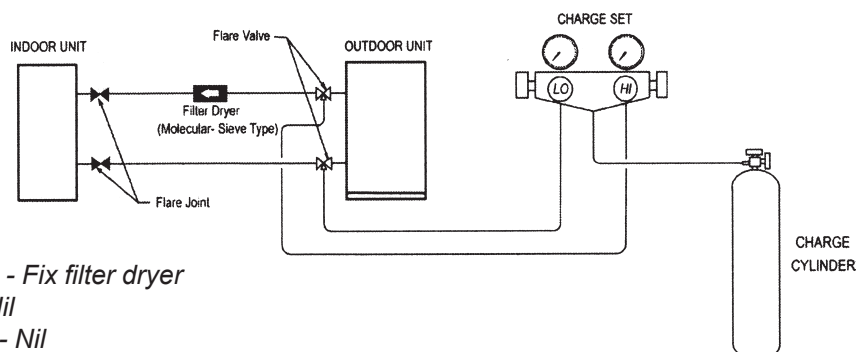

CAUTION FOR R407C / R410A

Avoid prolong exposure of an opened compressor, or the internal part of refrigerant piping to moist air. The POE oil in the compressor and piping can absorb moisture from air.

Special Precautions when Dealing with Refrigerant R410A Unit

1) What is new Refrigerant R410A?

R410A is a new HFC refrigerant which does not damage the ozone layer. The working pressure of this new refrigerant is 1.6 times higher than conventional refrigerant (R22), thus proper installation / servicing is essential.

2) Components

Mixture of composition by weight : R32(50%) and R125(50%)

3) Characteristic

- R410A liquid and vapor components have different compositions when the fluid evaporates or condenses. Hence, when leak occurs and only vapor leaks out, the composition of the refrigerant mixture left in the system will change and subsequently affect the system performance. **DO NOT** add new refrigerant to leaked system. It is recommended that the system be evacuated thoroughly before recharging with R410A.
- When refrigerant R410A is used, the composition will differ depending on whether it is in gaseous or liquid phase.
Hence when charging R410A, ensure that only liquid is being withdrawn from the cylinder or can. This is to make certain that only original composition of R410A is being charged into the system.
- POE oil is used as lubricant for R410A compressor, which is different from the mineral oil used for R22 compressor.
Extra precaution must be taken to avoid exposing the R410A system to moist air.

4) Check List Before Installation / Servicing

- Tubing
Refrigerant R410A is more easily affected by dust or moisture compared with R22, make sure to temporarily cover the ends of the tubing prior to installation
- Compressor oil
No additional charge of compressor oil is permitted.
- Refrigerant
No other refrigerant other than R410A
- Tools (size of service port is different from R22 system)
Tools specifically for R410A only (must not be used for R22 or other refrigerant)
 - i) Gauge manifold and charging hose
 - ii) Gas leak detector
 - iii) Refrigerant cylinder/charging cylinder
 - iv) Vacuum pump c/w adapter
 - v) Flare tools
 - vi) Refrigerant recovery machine

5) Handling and Installation Guidelines

Like R22 systems, the handling and installation of R410A system are closely similar. All precautionary measures; such as ensuring no moisture, no dirt or chips in the system, clean brazing using nitrogen, and thorough leak check and vacuuming are equally important requirements. However, due to its hygroscopic POE oil, additional precautions must be taken to ensure optimum and trouble-free system operation.

- a) During installation or servicing, avoid prolong exposure of the internal part of the refrigerant system to moist air. Residual POE oil in the piping and components can absorb moisture from the air.
- b) Ensure that the compressor is not exposed to open air for more than the recommended time specified by its manufacturer (typically less than 10 minutes). Remove the seal-plugs only when the compressor is about to be brazed.
- c) The system should be thoroughly vacuumed to 1.0 Pa (700mmHg) or lower. This vacuuming level is more stringent than R22 system so as to ensure no incompressible gas and moisture in the system.

- d) When charging R410A, ensure that only liquid is being withdrawn from the cylinder or can. This is to ensure that only the original composition of R410A is being delivered into the system. The liquid composition can be different from the vapor composition.

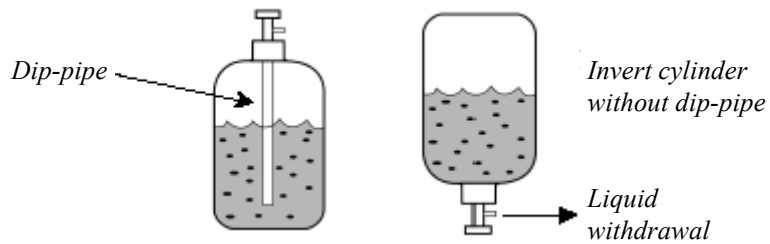

- e) Normally, the R410A cylinder or can is being equipped with a dip-pipe for liquid withdrawal. However, if the dip-pipe is not available, invert the cylinder or can so as to withdraw liquid from the valve at the bottom.

Sound Data

Sound Power

Model	Ext. Static (mmAq)	Speed	1/1 Octave A-weighted Sound Power (dB), ref 1pW							Overall A (dBA)
			125Hz	250Hz	500Hz	1kHz	2kHz	4kHz	8kHz	
MCC 010C/CR	5	High	57	54	52	52	51	46	44	57
	4	Medium	54	51	50	49	48	43	39	54
	3	Low	51	48	47	46	44	39	35	51
MCC 015C/CR	5	High	60	58	57	56	54	48	44	61
	4	Medium	56	55	54	53	50	44	40	58
	3	Low	52	50	49	48	44	37	34	52
MCC 020C/CR	6.5	High	63	62	61	61	59	55	51	65
	6	Medium	61	61	59	60	58	53	49	64
	3.5	Low	57	56	56	56	53	48	44	60
MCC 025C/CR	5.5	High	63	52	61	62	59	56	53	66
	4	Medium	61	60	59	60	57	53	50	64
	3	Low	58	57	56	57	54	49	47	61
MCC 028C/CR	10	Super High	62	65	61	63	60	57	56	67
	8	High	59	61	58	61	57	54	52	64
	7	Medium	56	57	55	57	54	50	48	61
	6	Low	52	53	51	53	50	45	41	57
MCC 030C/CR	21	Super High	68	69	71	72	69	66	65	76
	17	High	65	66	68	69	65	63	60	73
	13	Medium	61	62	64	65	61	58	55	69
	9	Low	56	58	60	61	57	53	49	64
MCC 038C/CR	14	Super High	74	75	74	75	72	70	69	80
	12	High	70	70	71	72	68	66	64	76
	11	Medium	67	67	68	70	65	62	60	73
	9	Low	65	64	65	66	61	58	56	70
MCC 040C/CR	21	Super High	69	71	72	74	71	68	67	78
	18	High	65	68	70	72	68	66	64	76
	13	Medium	65	65	67	68	64	62	59	72
	9.5	Low	59	61	63	64	60	57	54	68
MCC 050C/CR	18	Super High	70	71	73	74	72	69	67	78
	16	High	67	69	71	72	69	66	64	76
	14	Medium	66	66	69	69	66	63	61	73
	11	Low	63	64	66	67	62	60	57	70
MCC 060C/CR	18	Super High	70	71	73	75	73	70	68	79
	16	High	69	70	72	74	71	69	68	78
	14	Medium	69	68	70	71	67	65	63	75
	10	Low	64	65	67	67	63	61	59	71

Duct Discharge Sound Power Level: Test with 5ft length discharge duct, terminated flush with internal wall of reverberation room.

Sound Pressure

Model	Ext. Static (mmAq)	Speed	1/1 Octave A-weighted Sound Pressure (dBA), ref 20µPa							Overall A (dBA)	Noise Criteria
			125Hz	250Hz	500Hz	1kHz	2kHz	4kHz	8kHz		
MCC 010C/CR	5	High	33	30	30	29	22	16	10	33	27
	4	Medium	31	28	28	26	20	13	8	30	24
	3	Low	28	25	24	22	16	10	7	26	20
MCC 015C/CR	5	High	39	36	34	32	27	18	11	37	31
	4	Medium	35	34	32	29	23	14	9	34	27
	3	Low	32	29	28	25	17	11	8	29	23
MCC 020C/CR	6.5	High	42	39	36	34	28	22	17	38	33
	6	Medium	41	37	34	31	26	20	15	36	30
	3.5	Low	40	36	32	29	23	18	13	34	27
MCC 025C/CR	5.5	High	42	41	37	34	31	29	23	40	33
	4	Medium	41	40	36	33	29	28	22	39	32
	3	Low	36	35	33	31	26	27	21	36	30
MCC 028C/CR	10	Super High	48	45	42	38	34	29	26	44	37
	8	High	45	42	39	35	31	26	22	41	34
	7	Medium	42	38	37	32	28	22	17	38	32
	6	Low	36	33	33	27	23	16	11	34	27
MCC 030C/CR	21	Super High	54	50	46	45	40	34	30	49	44
	17	High	50	45	43	42	37	31	26	46	41
	13	Medium	45	40	40	38	32	26	20	42	37
	9	Low	42	36	37	33	28	22	15	38	32
MCC 038C/CR	14	Super High	56	57	53	50	46	41	36	55	49
	12	High	54	51	48	46	41	36	31	51	45
	11	Medium	51	48	46	45	37	32	26	48	44
	9	Low	47	45	44	41	34	28	22	45	40
MCC 040C/CR	21	Super High	56	49	49	46	41	37	32	51	45
	18	High	54	47	47	45	39	35	29	49	44
	13	Medium	49	42	43	41	35	31	24	45	40
	9.5	Low	45	39	41	37	30	26	18	41	36
MCC 050C/CR	18	Super High	56	50	50	49	44	38	33	53	48
	16	High	54	49	49	48	43	37	32	52	47
	14	Medium	53	47	46	47	40	35	29	50	46
	11	Low	51	45	44	44	36	32	26	47	43
MCC 060C/CR	18	Super High	57	50	51	51	46	39	35	55	50
	16	High	55	49	49	50	44	37	33	53	49
	14	Medium	53	46	47	47	39	34	28	50	46
	10	Low	51	43	44	43	35	30	24	47	42

Microphone position: 1.4m below the centre of the unit. (GB Standard - GB/D17758)

Tested with 2m length duct at the air discharge outlet and air return inlet.

Measuring Location:

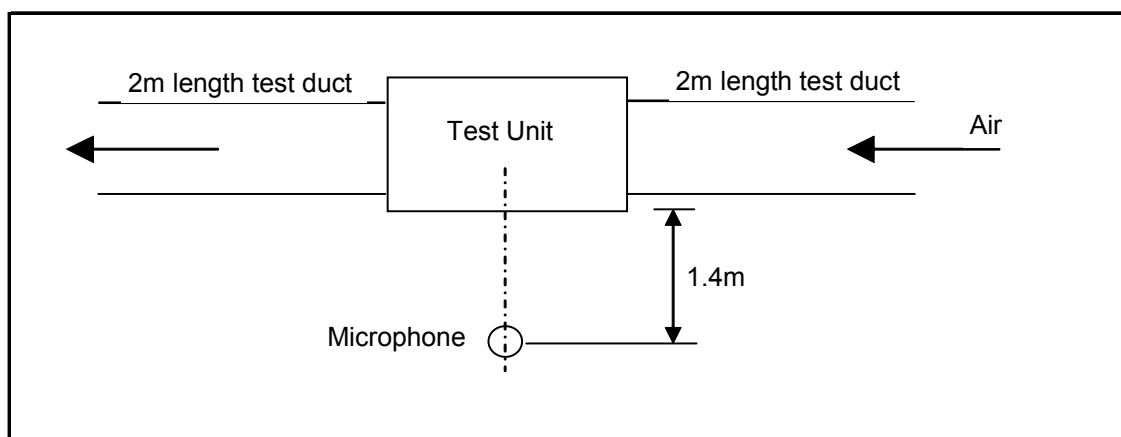

NC Curves

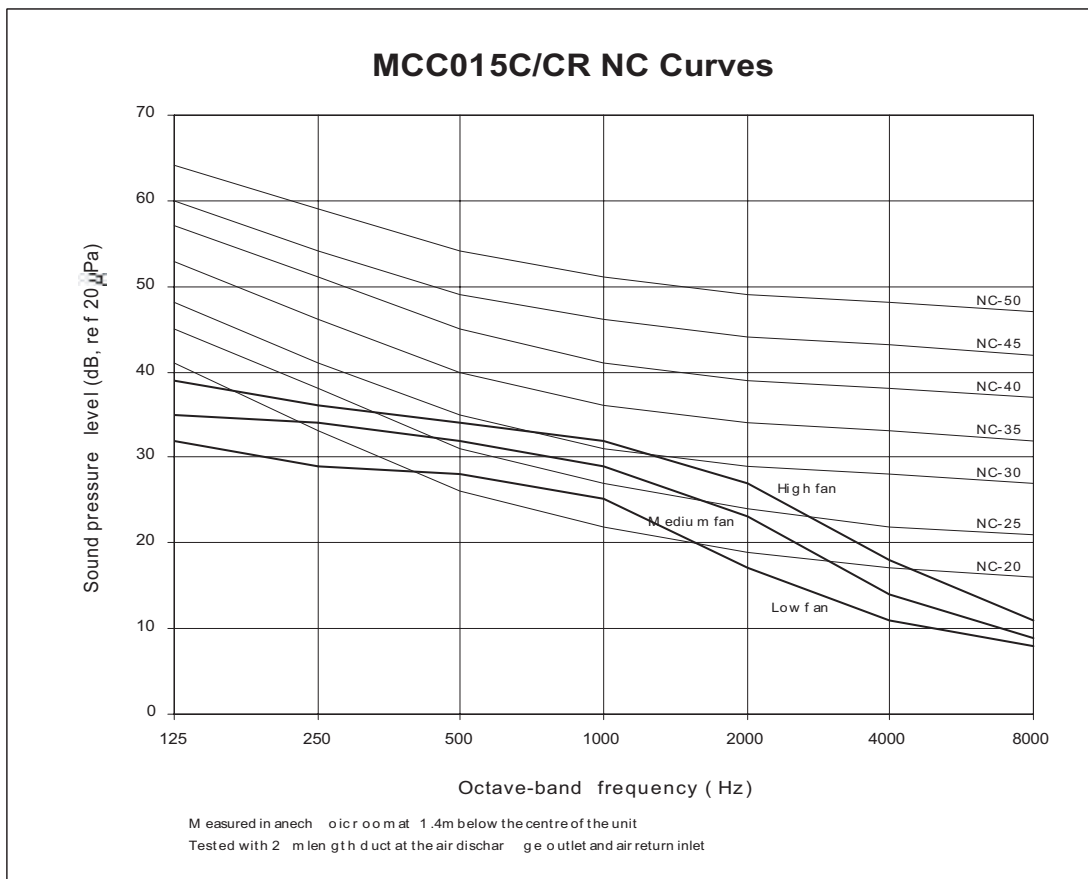
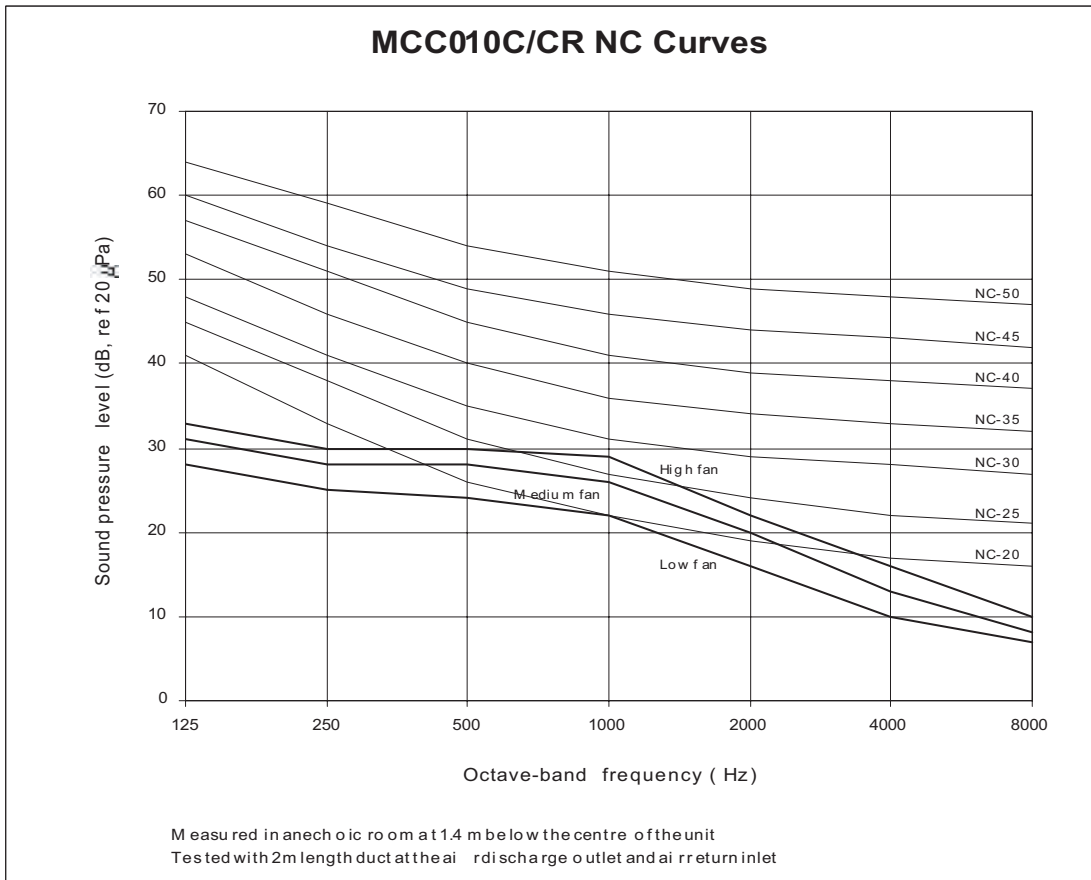

MCC020C/CR NC Curves

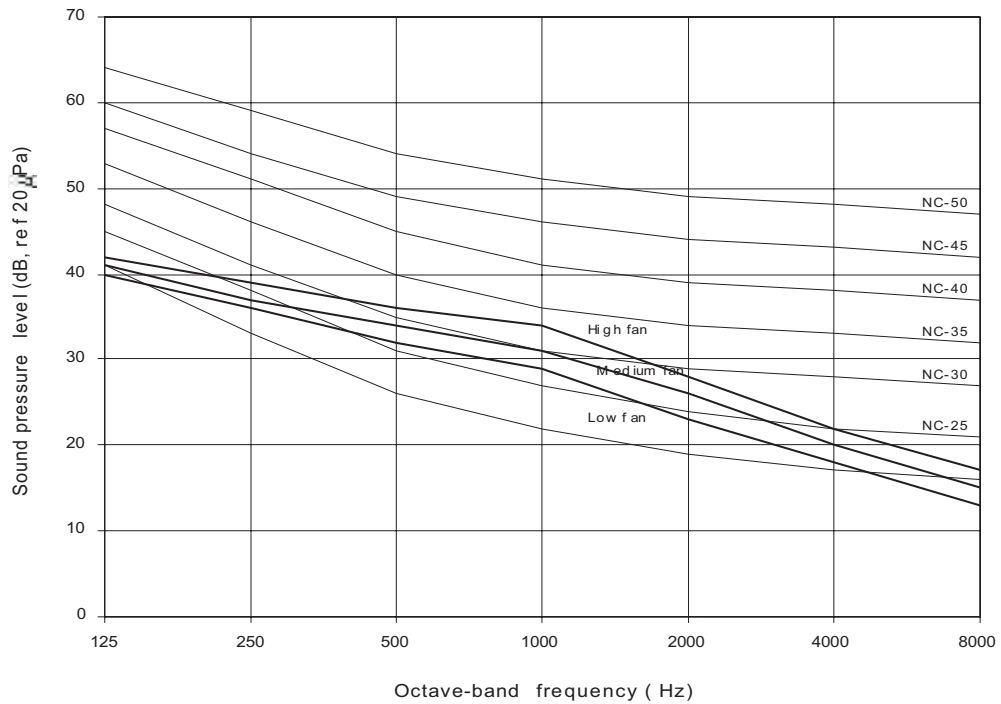

Measured in anechoic room at 1.4m below the centre of the unit
 Tested with 2m length duct at the air discharge outlet and air return inlet

MCC025C/CR NC Curves

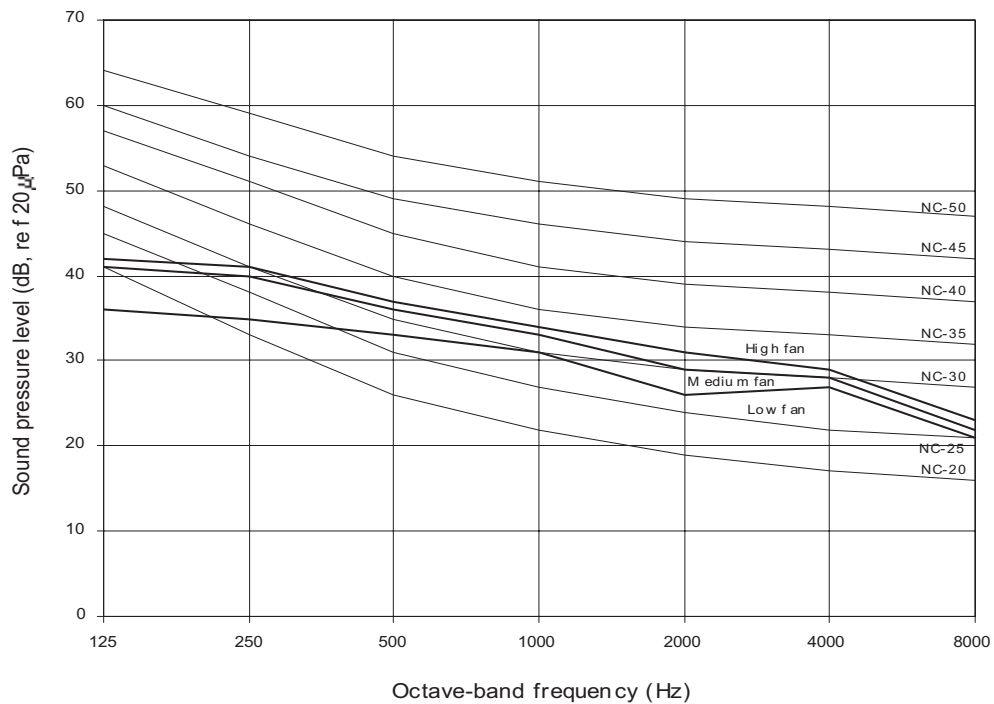

Measured in anechoic room at 1.4m below the centre of the unit
 Tested with 2m length duct at the air discharge outlet and air return inlet

MCC028C/CR NC Curves

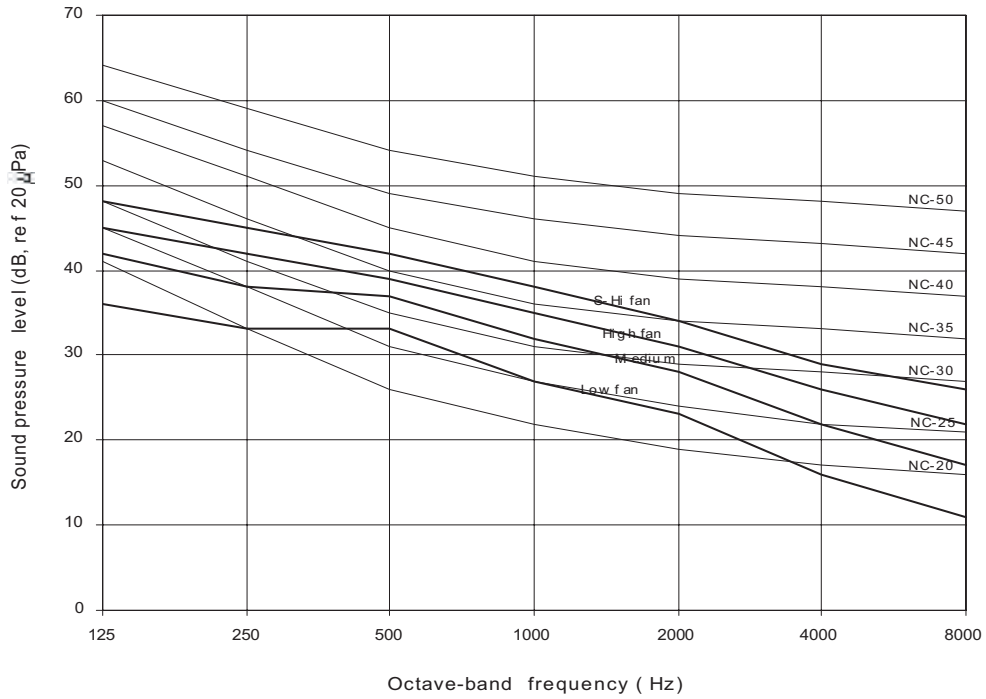

Measured in anechoic room at 1.4m below the centre of the unit
 Tested with 2m length duct at the air discharge outlet and air return inlet

MCC030C/CR NC Curves

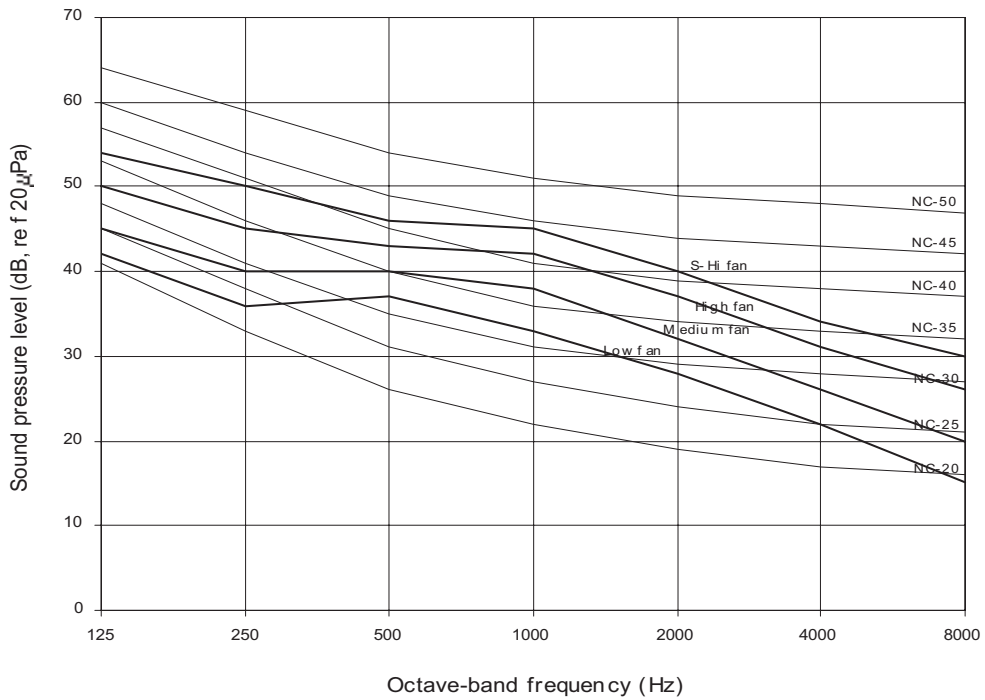

Measured in anechoic room at 1.4m below the centre of the unit
 Tested with 2m length duct at the air discharge outlet and air return inlet

MCC038C/CR NC Curves

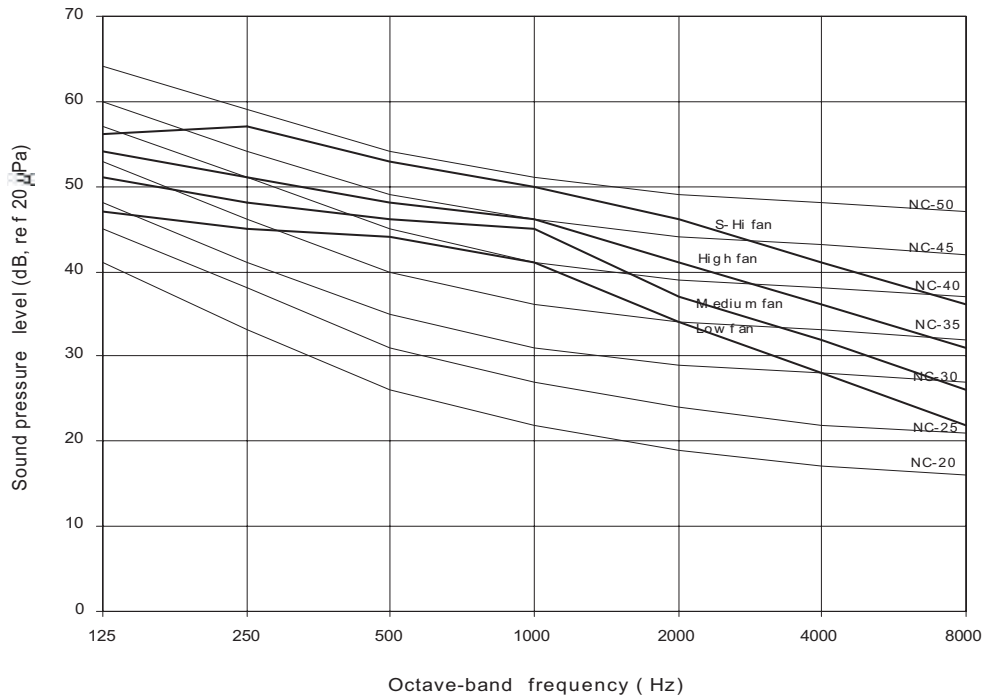

Measured in anechoic room at 1.4m below the centre of the unit
 Tested with 2m length duct at the air discharge outlet and air return inlet

MCC040C/CR NC Curves

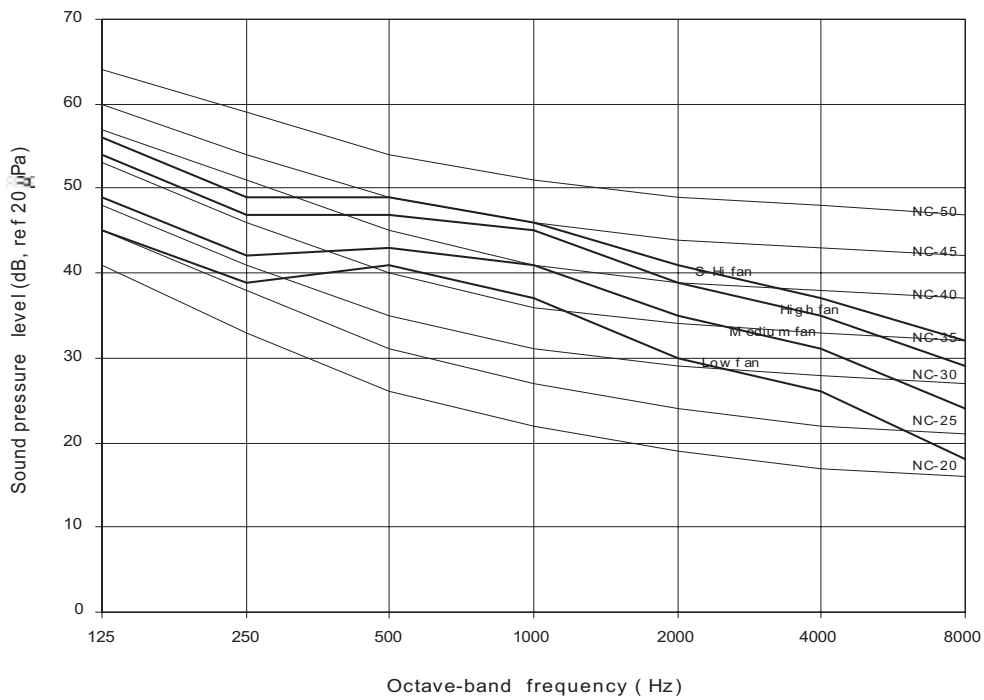

Measured in anechoic room at 1.4m below the centre of the unit
 Tested with 2m length duct at the air discharge outlet and air return inlet

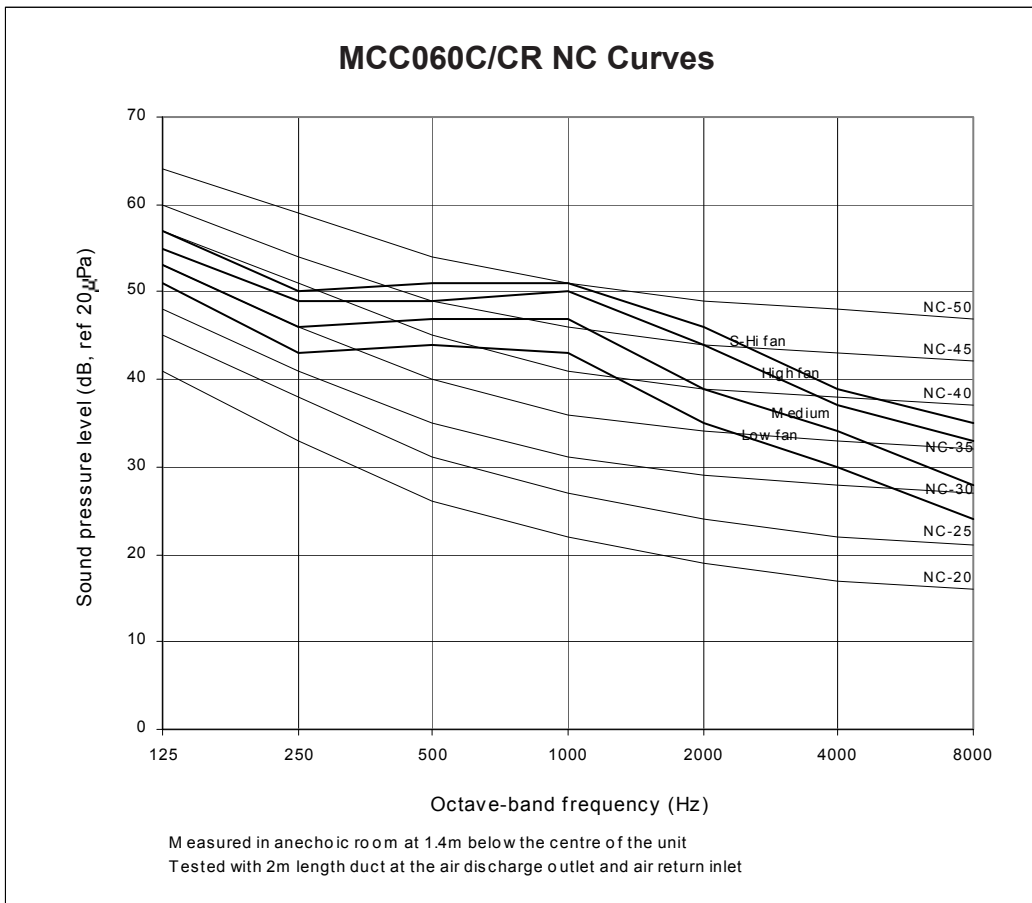
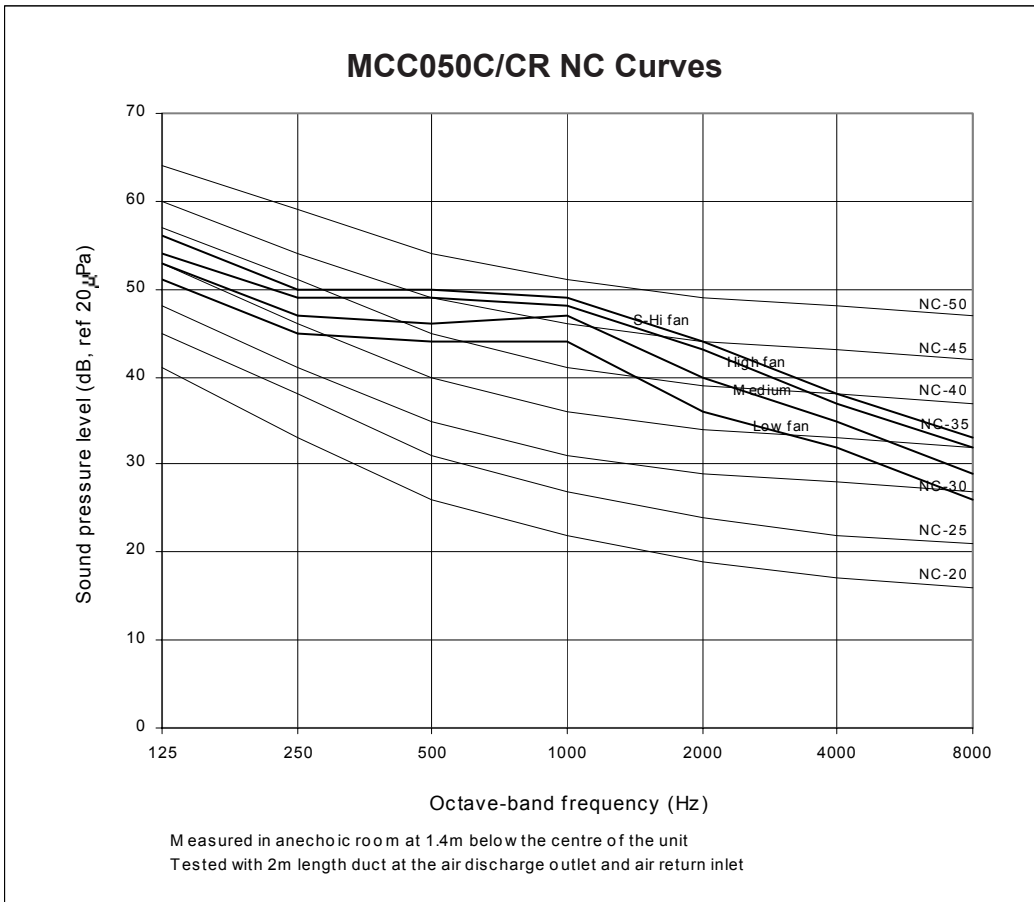

Selection Process

**FAN PERFORMANCE CURVE
MCC 010C/CR
(High Static Motor)**

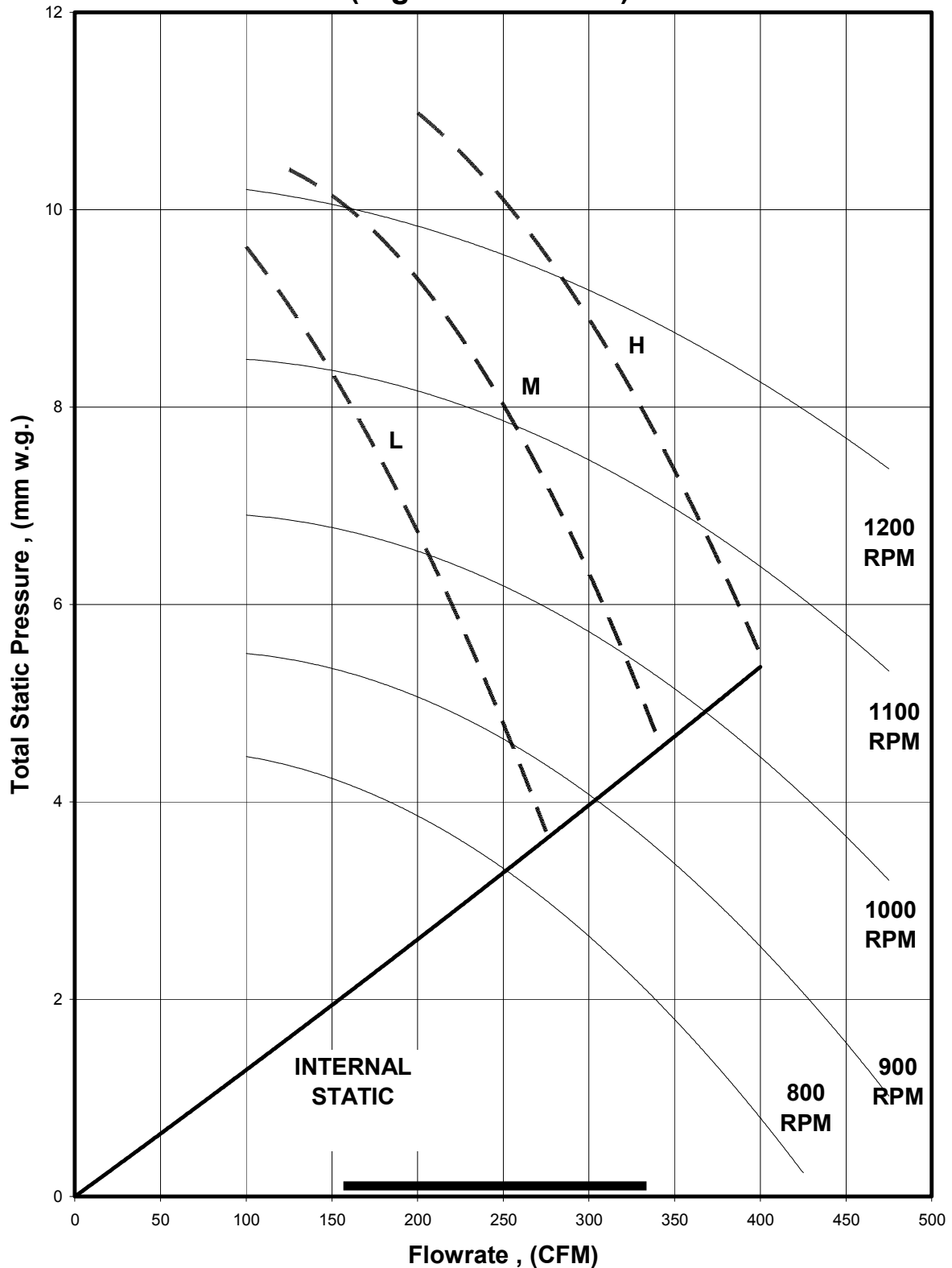

FAN PERFORMANCE CURVE MCC 015C/CR (High Static Motor)

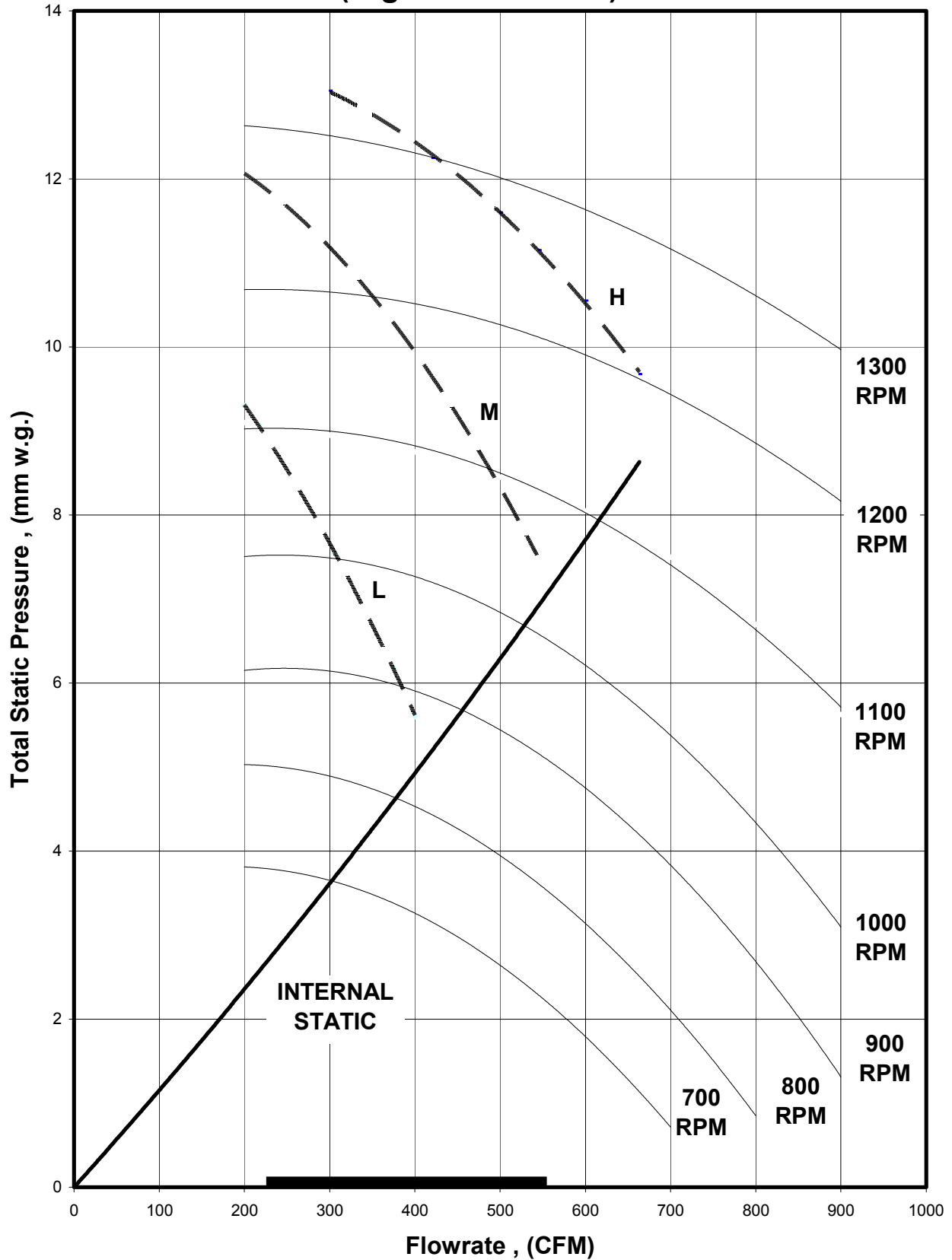

FAN PERFORMANCE CURVE MCC 020C/CR (High Static Motor)

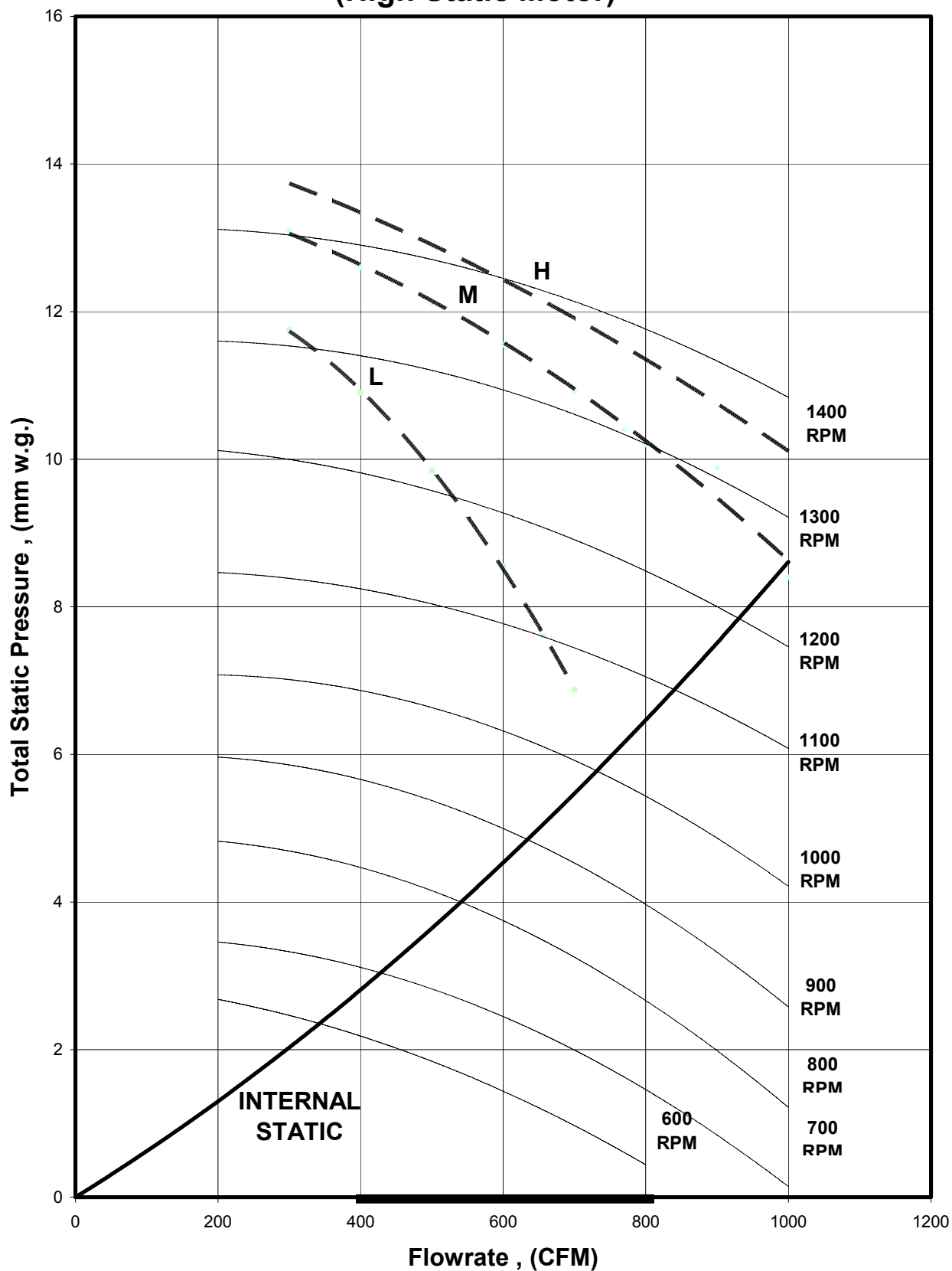

FAN PERFORMANCE CURVE MCC 025C/CR (High Static Motor)

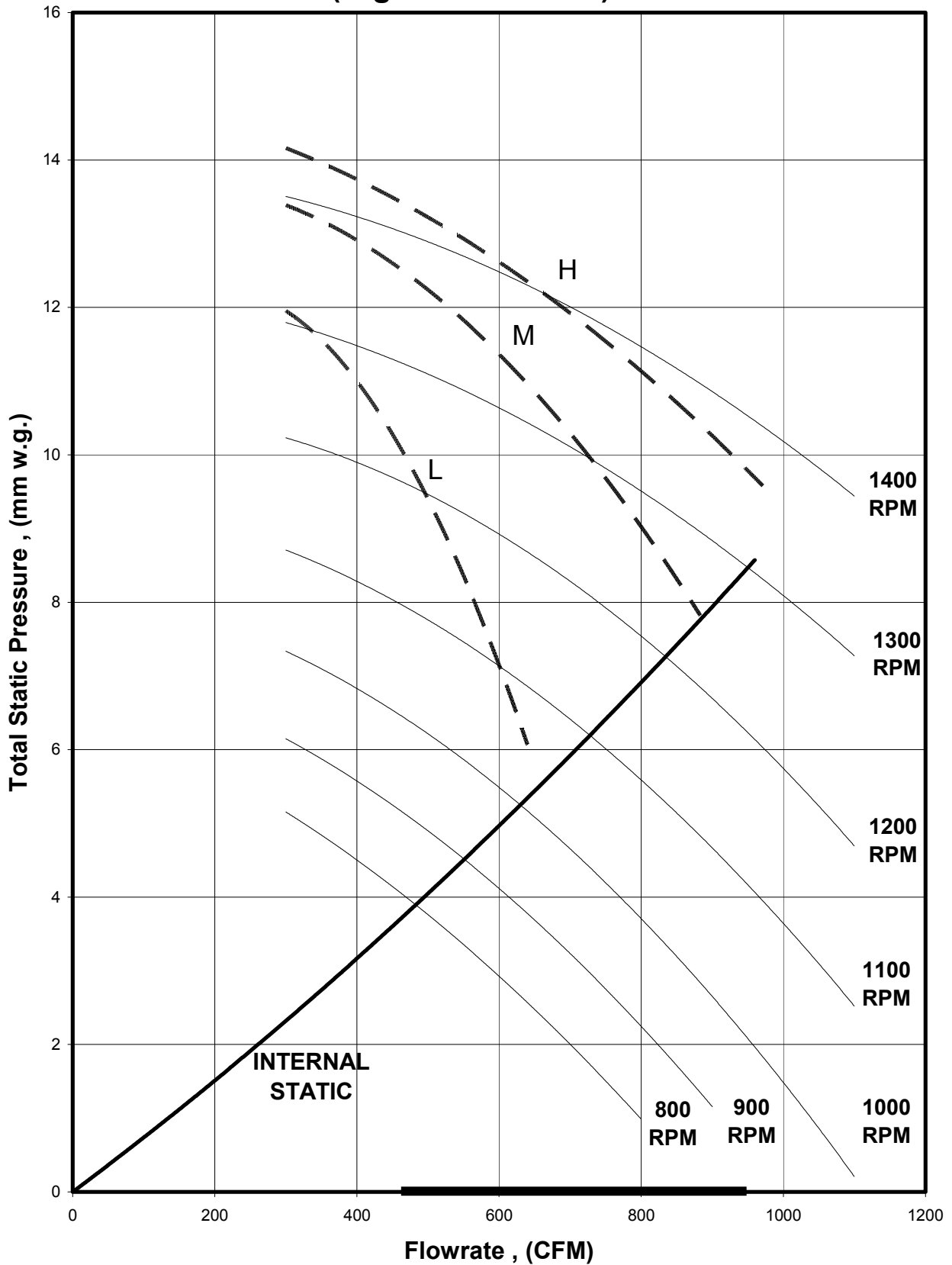

FAN PERFORMANCE CURVE MCC 028C/CR (High Static Motor)

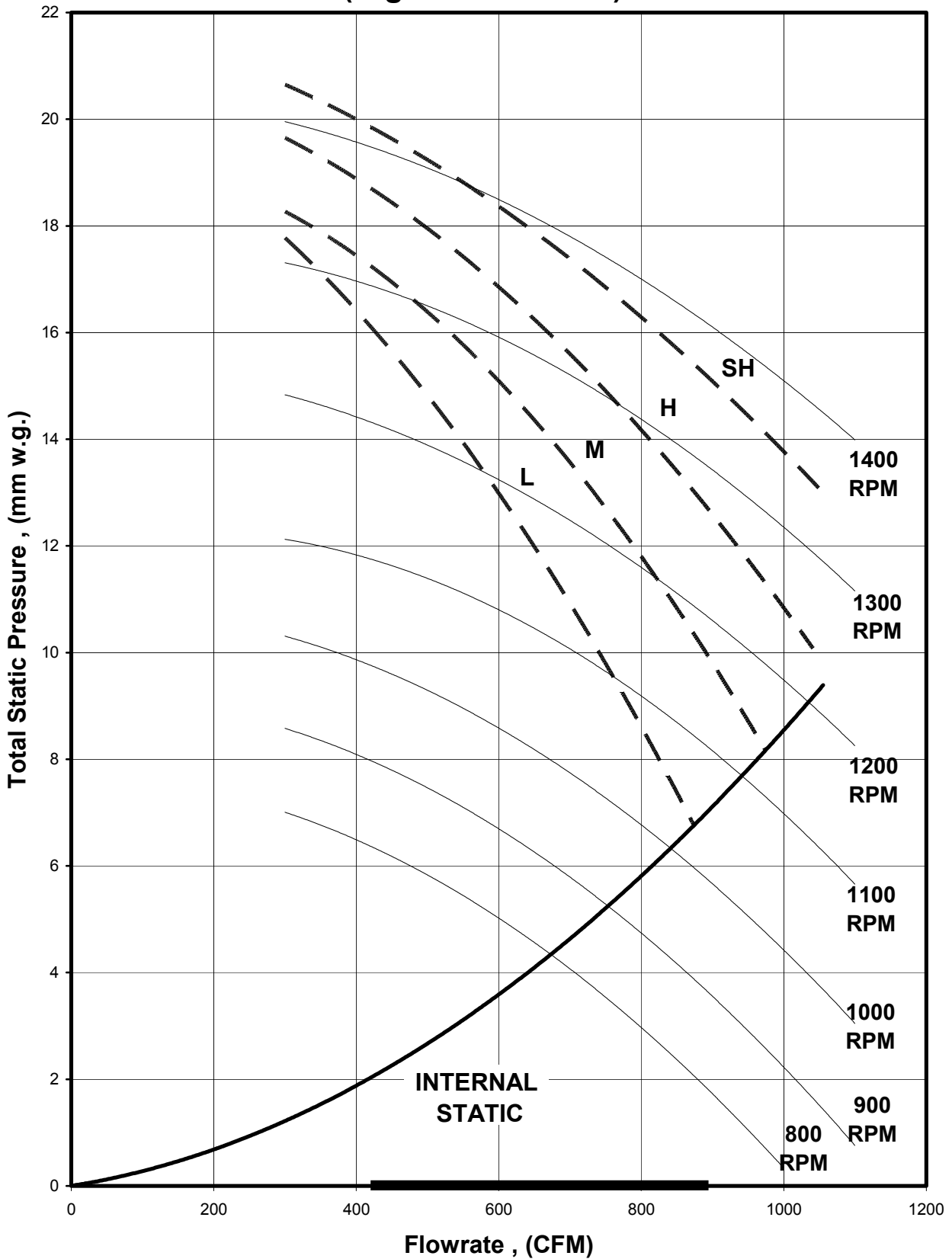

FAN PERFORMANCE CURVE MCC 030C/CR (High Static Motor)

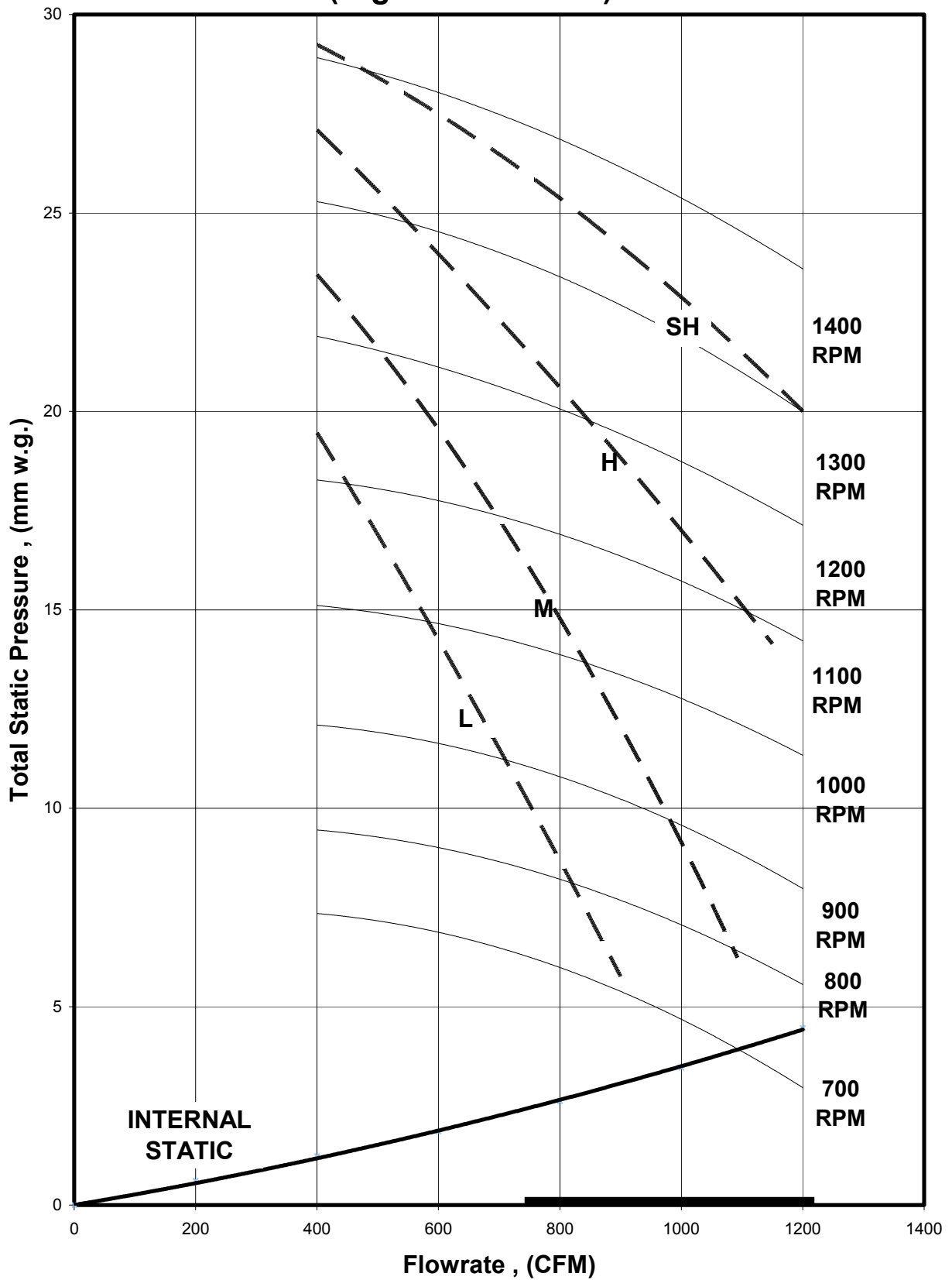

FAN PERFORMANCE CURVE MCC 038C/CR (High Static Motor)

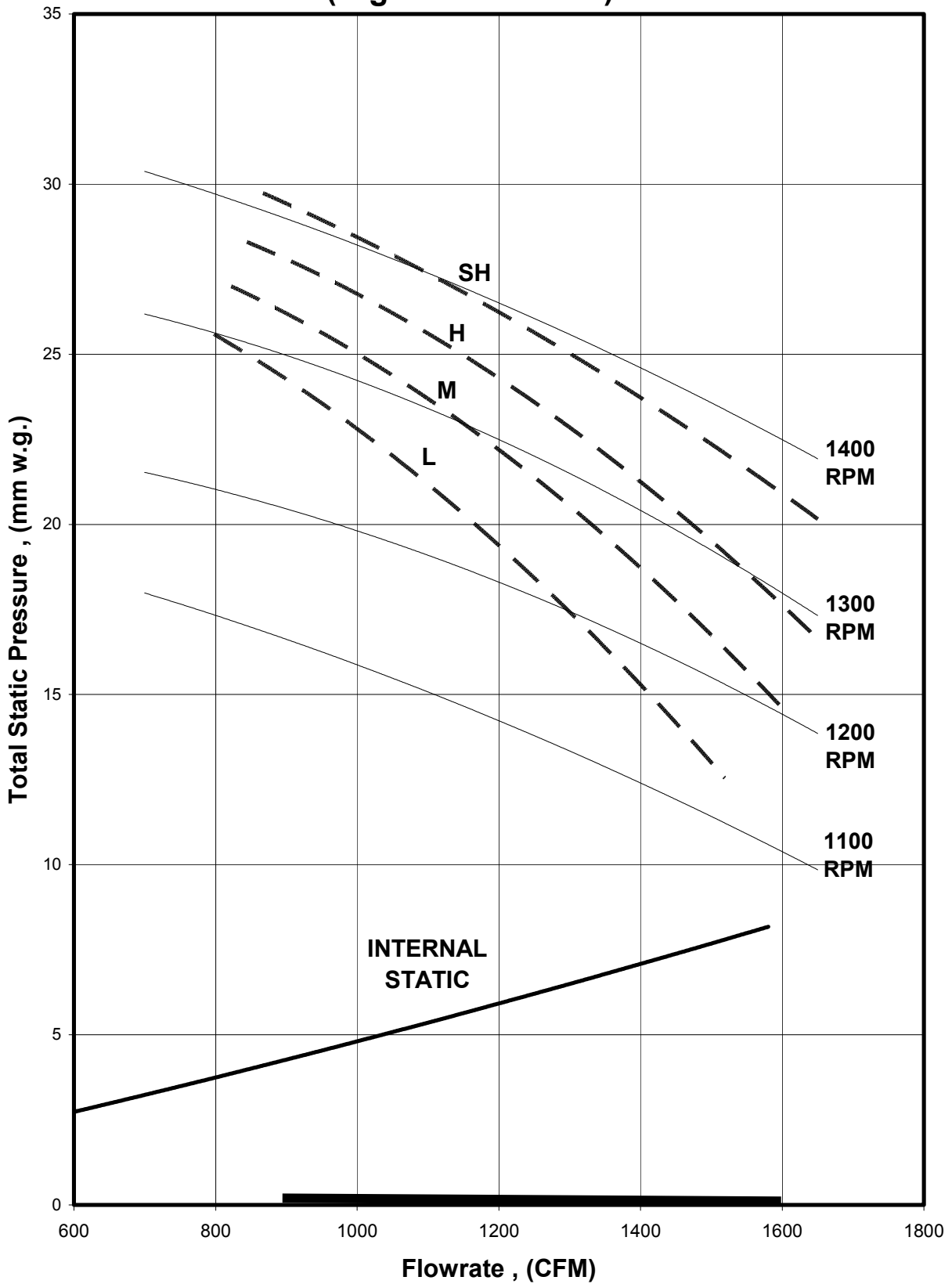

FAN PERFORMANCE CURVE

MCC 040C/CR

(High Static Motor)

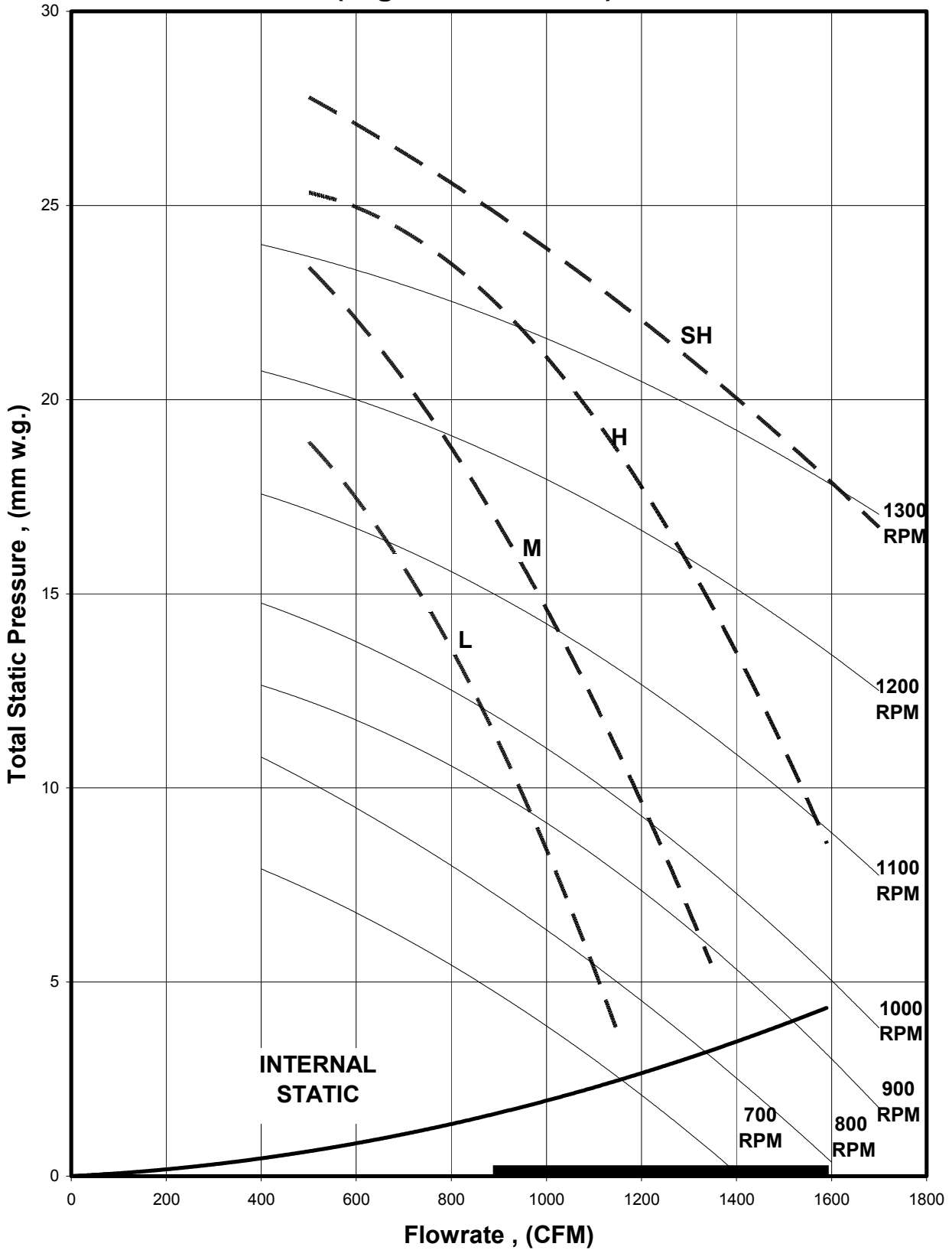

FAN PERFORMANCE CURVE MCC 050C/CR (High Static Motor)

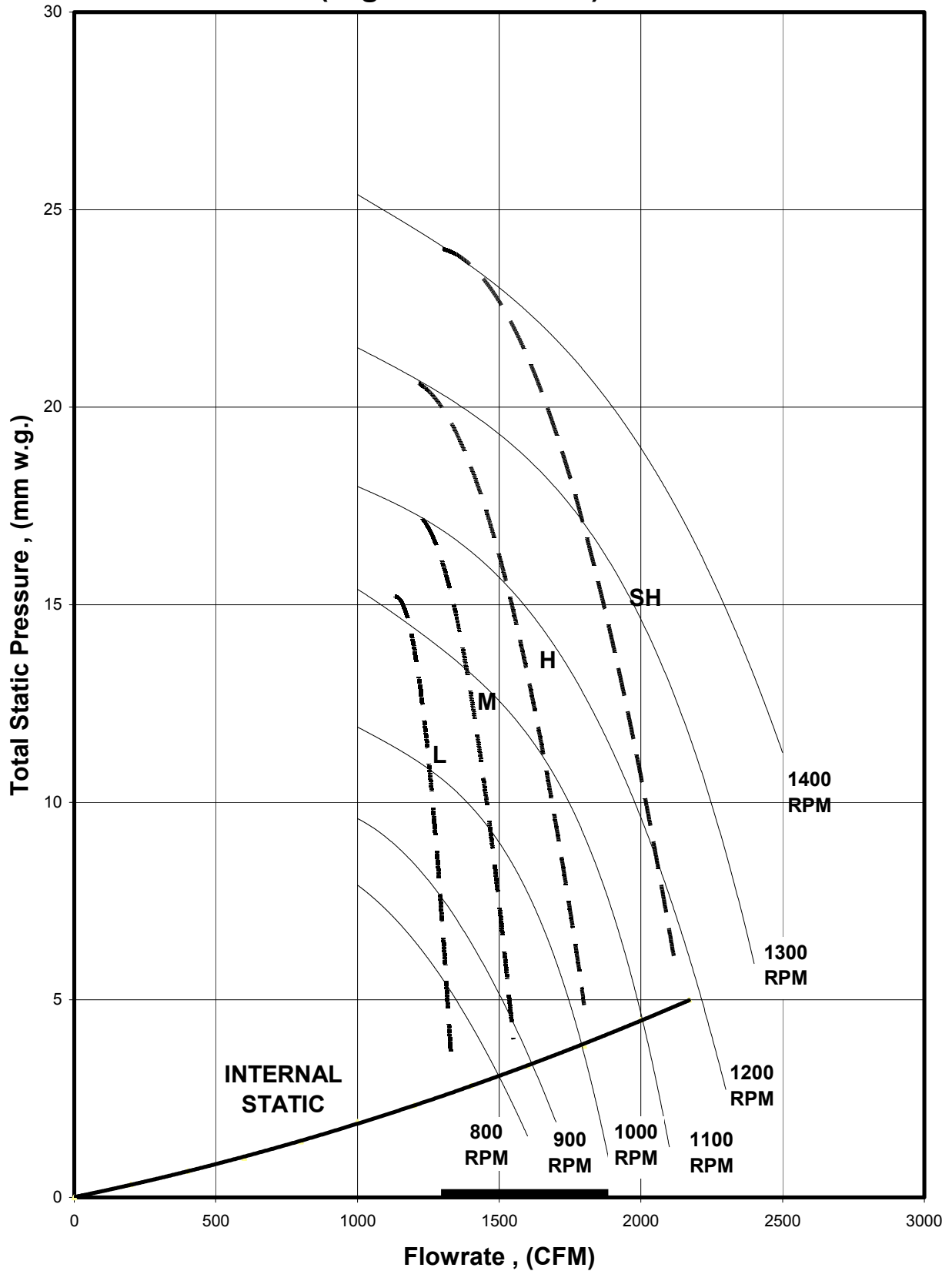

FAN PERFORMANCE CURVE MCC 060C/CR (High Static Motor)

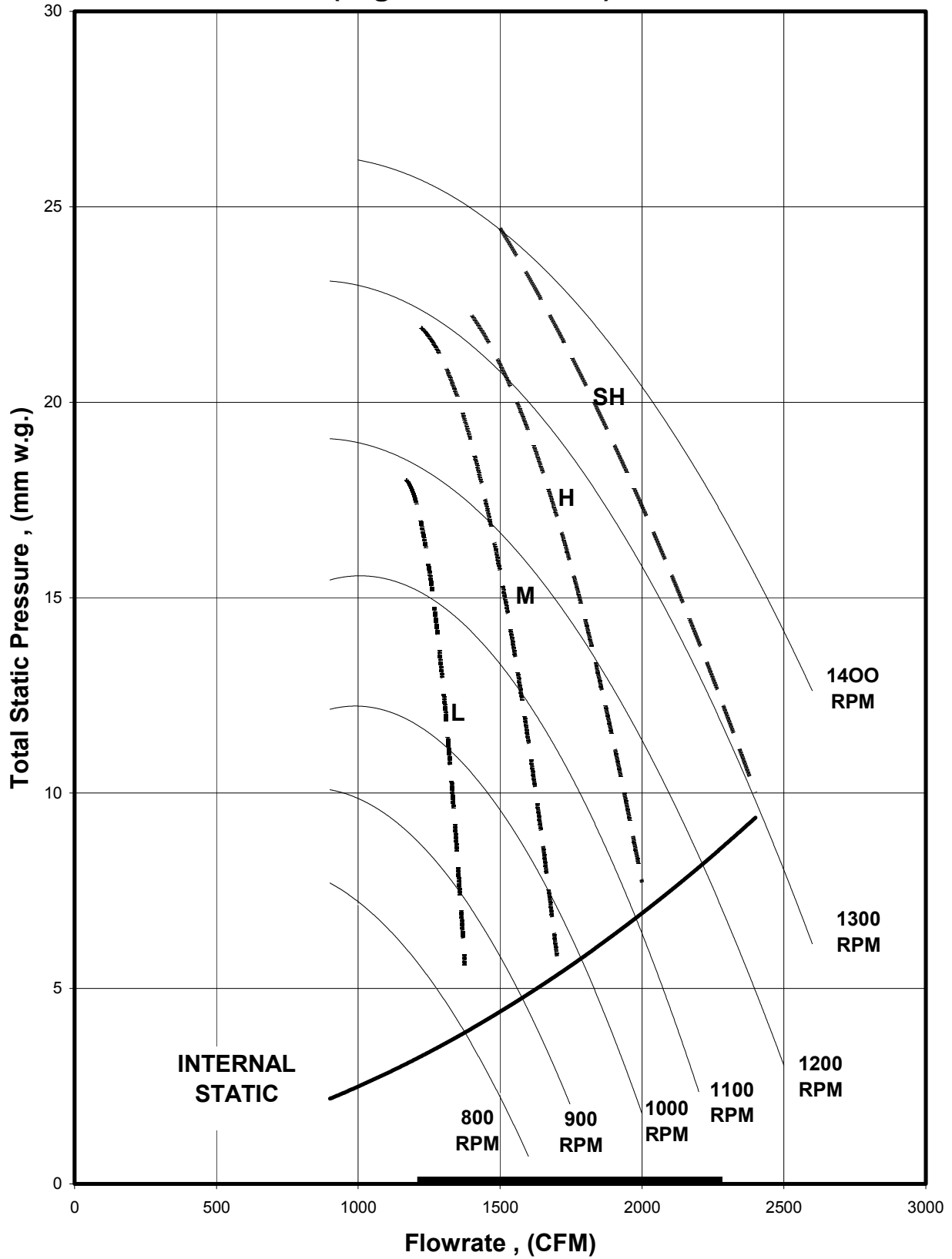

FAN PERFORMANCE CURVE

MCC 010C/CR

(Low Static Motor)

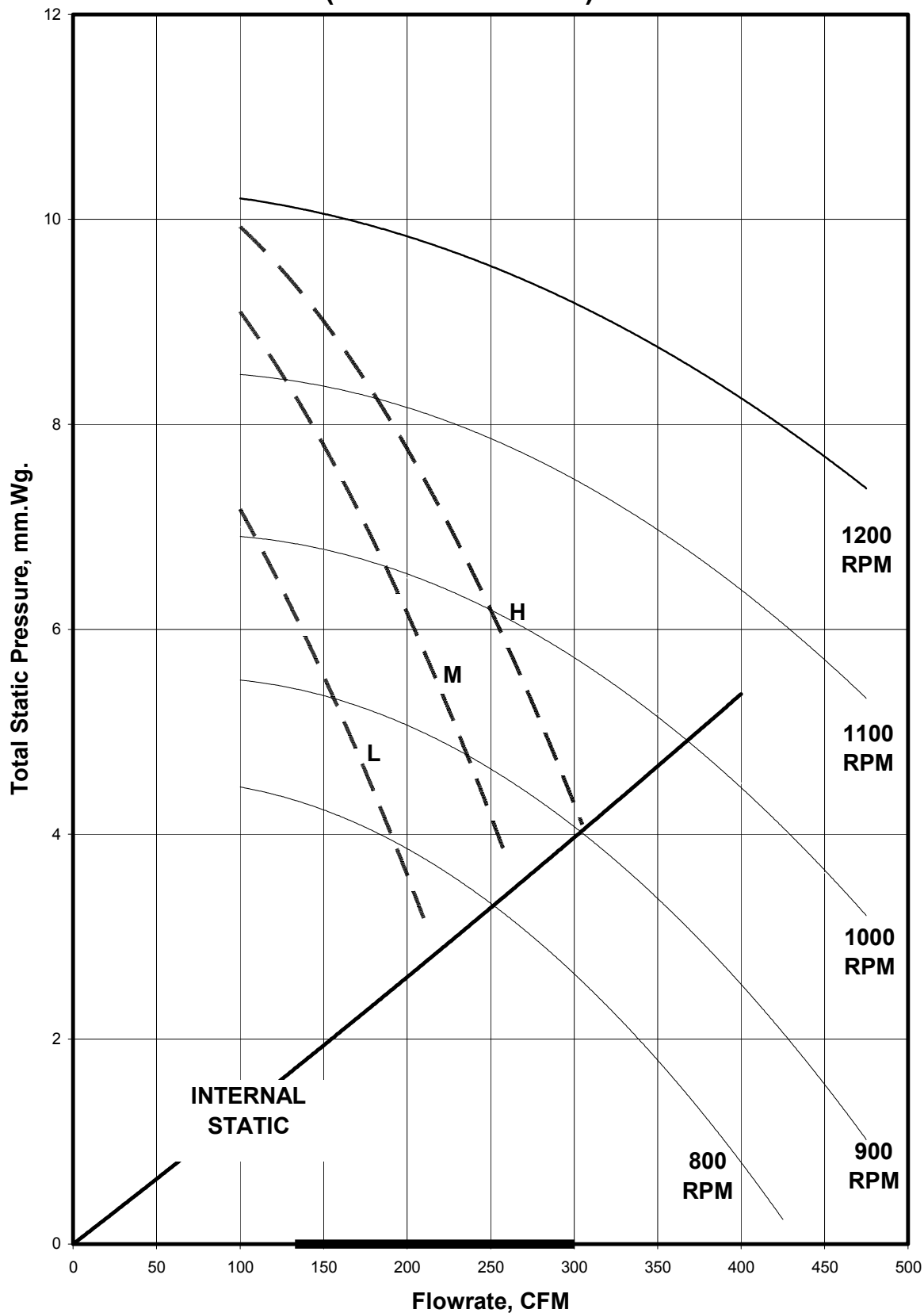

FAN PERFORMANCE CURVE

MCC 015C/CR

(Low Static Motor)

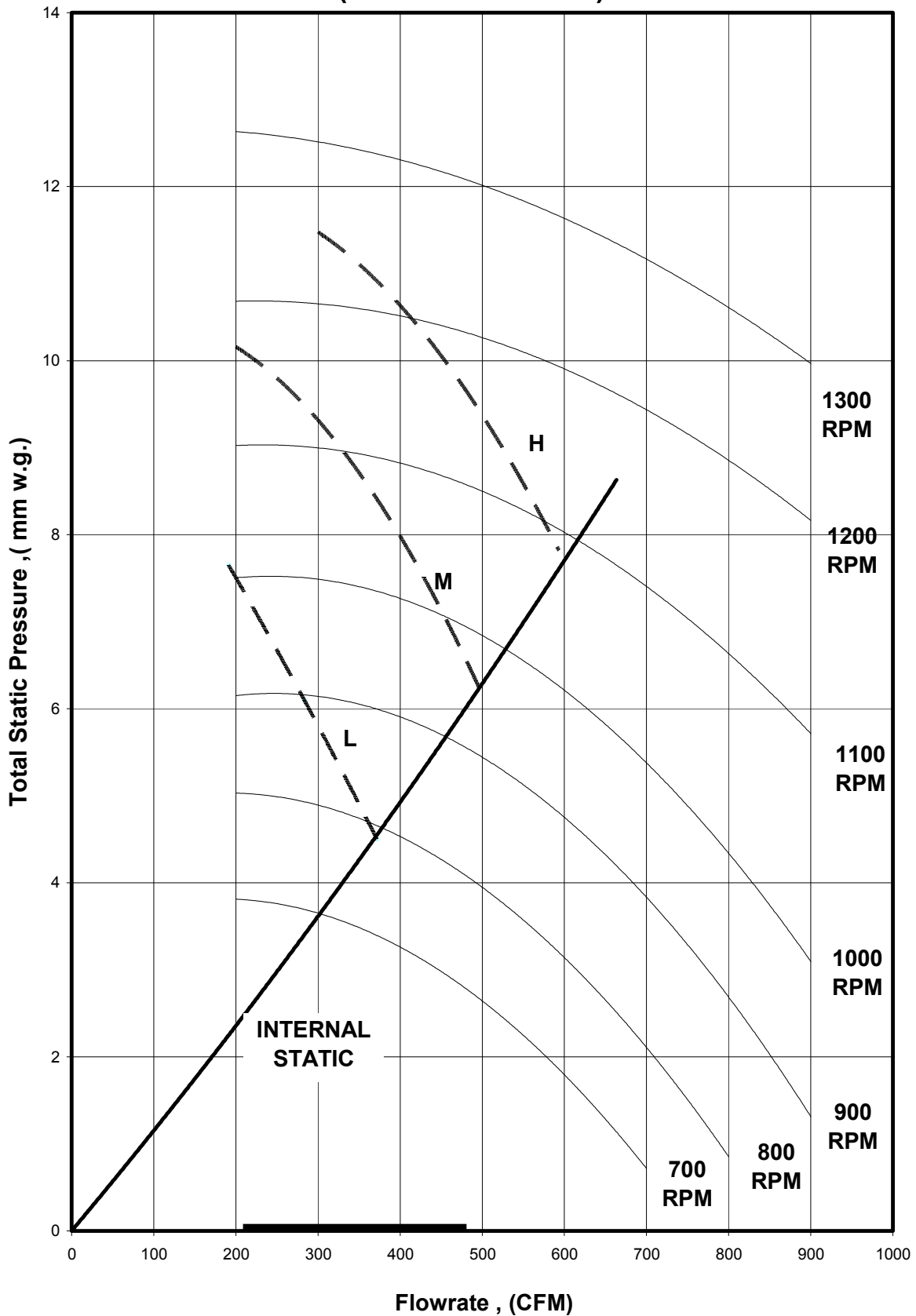

FAN PERFORMANCE CURVE MCC 020C/CR (Low Static Motor)

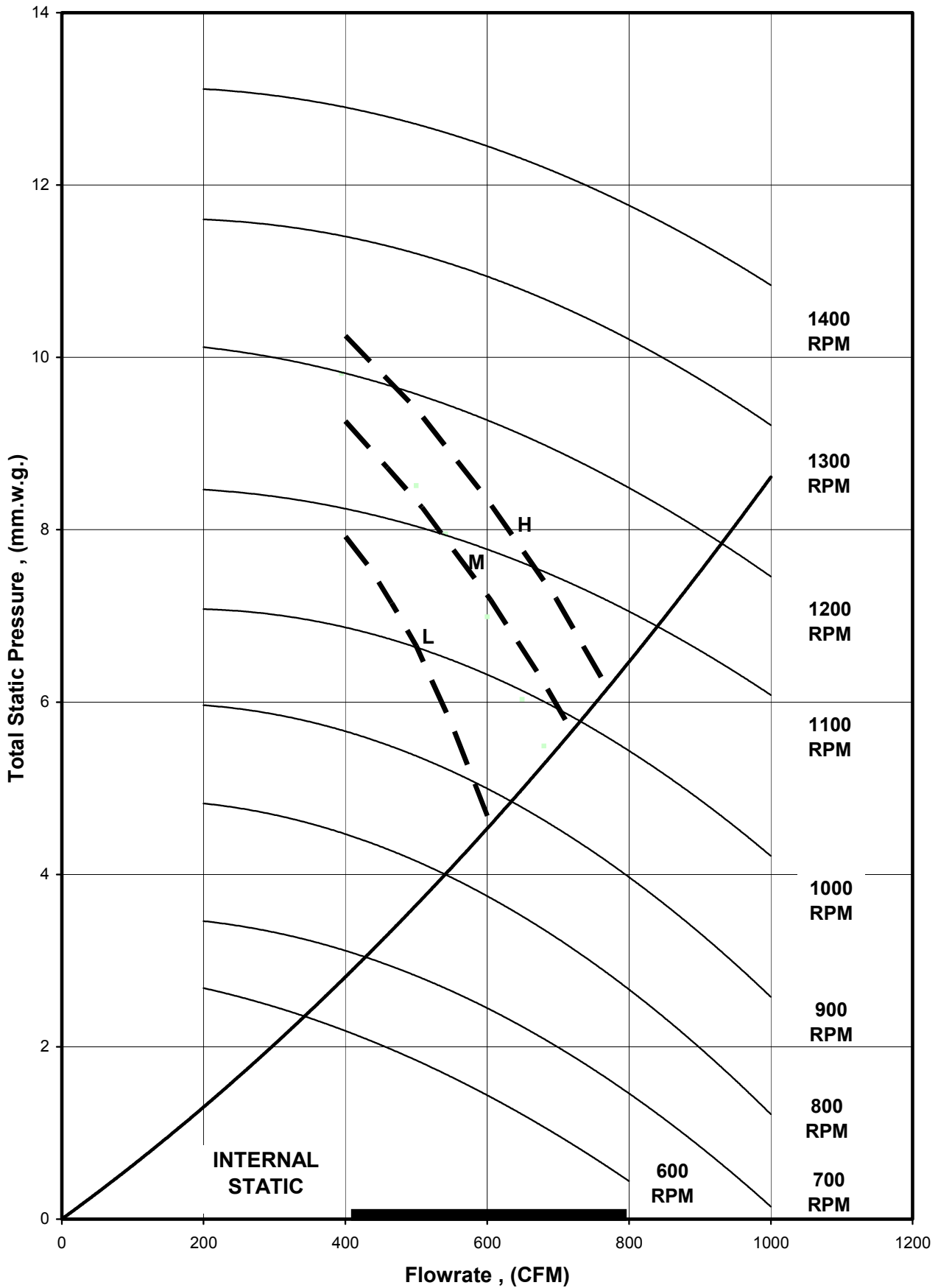

FAN PERFORMANCE CURVE

MCC 025C/CR

(Low Static Motor)

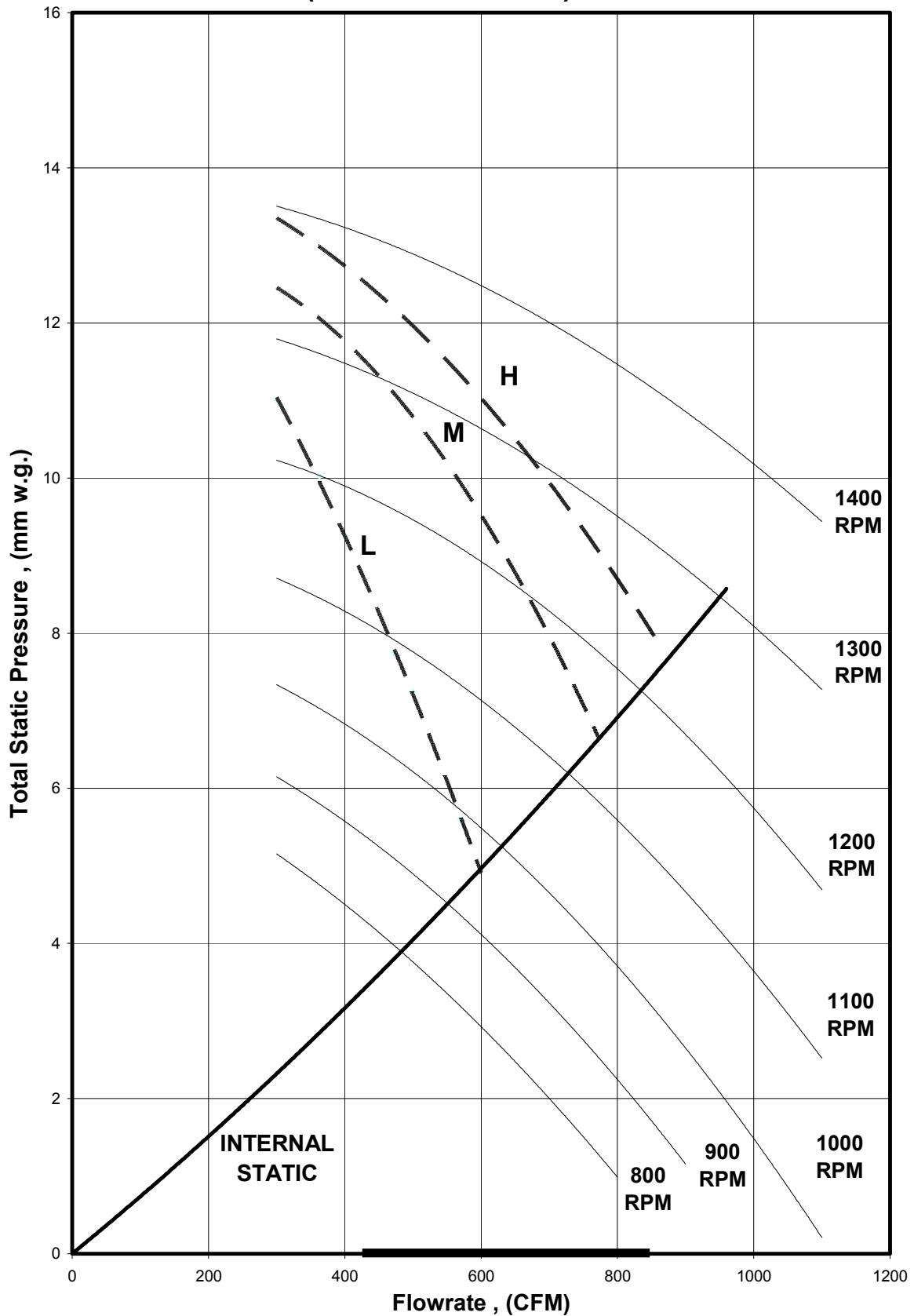

FAN PERFORMANCE CURVE MCC 030C/CR (Low Static Motor)

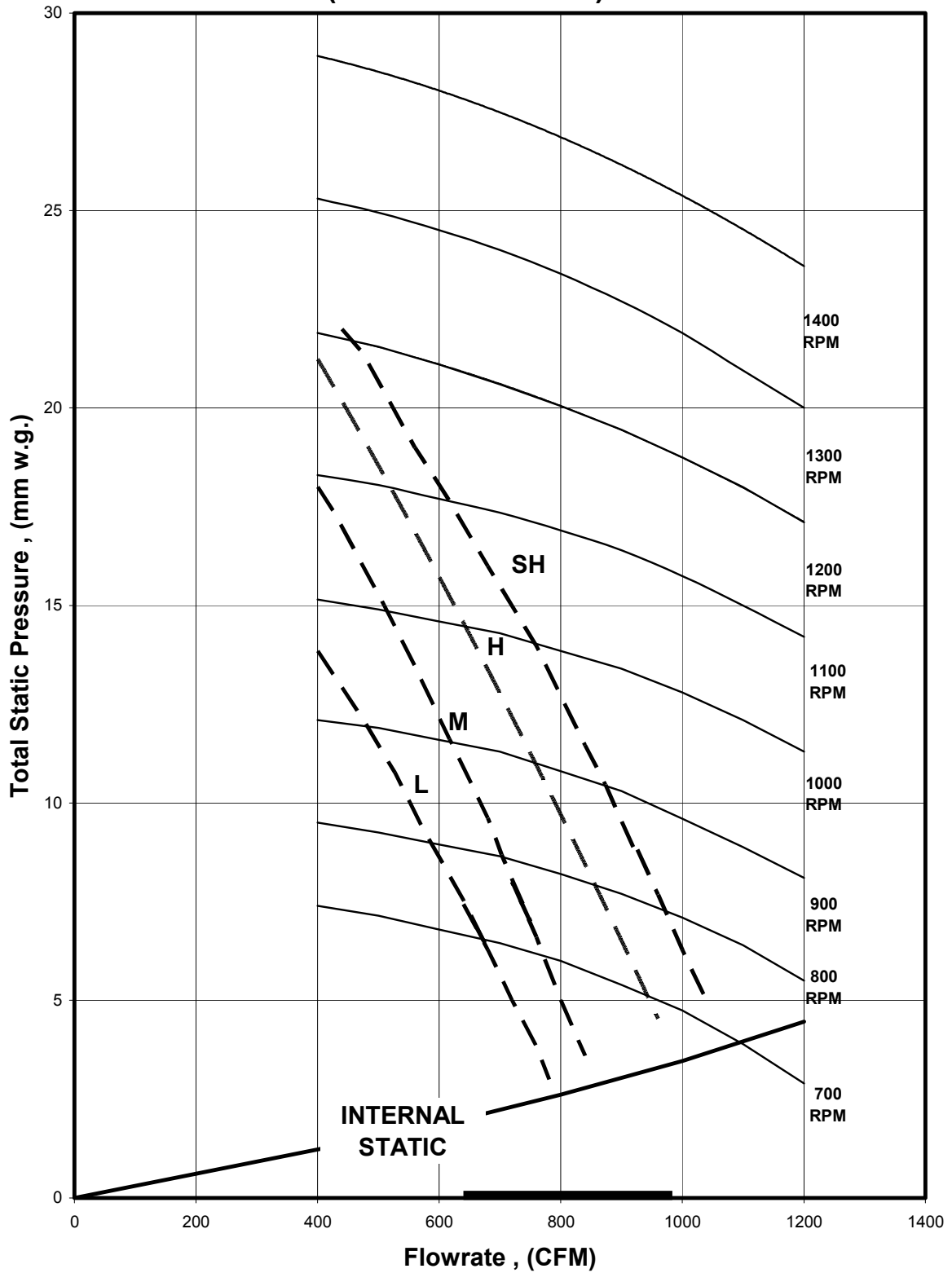

FAN PERFORMANCE CURVE MCC 040C/CR (Low Static Motor)

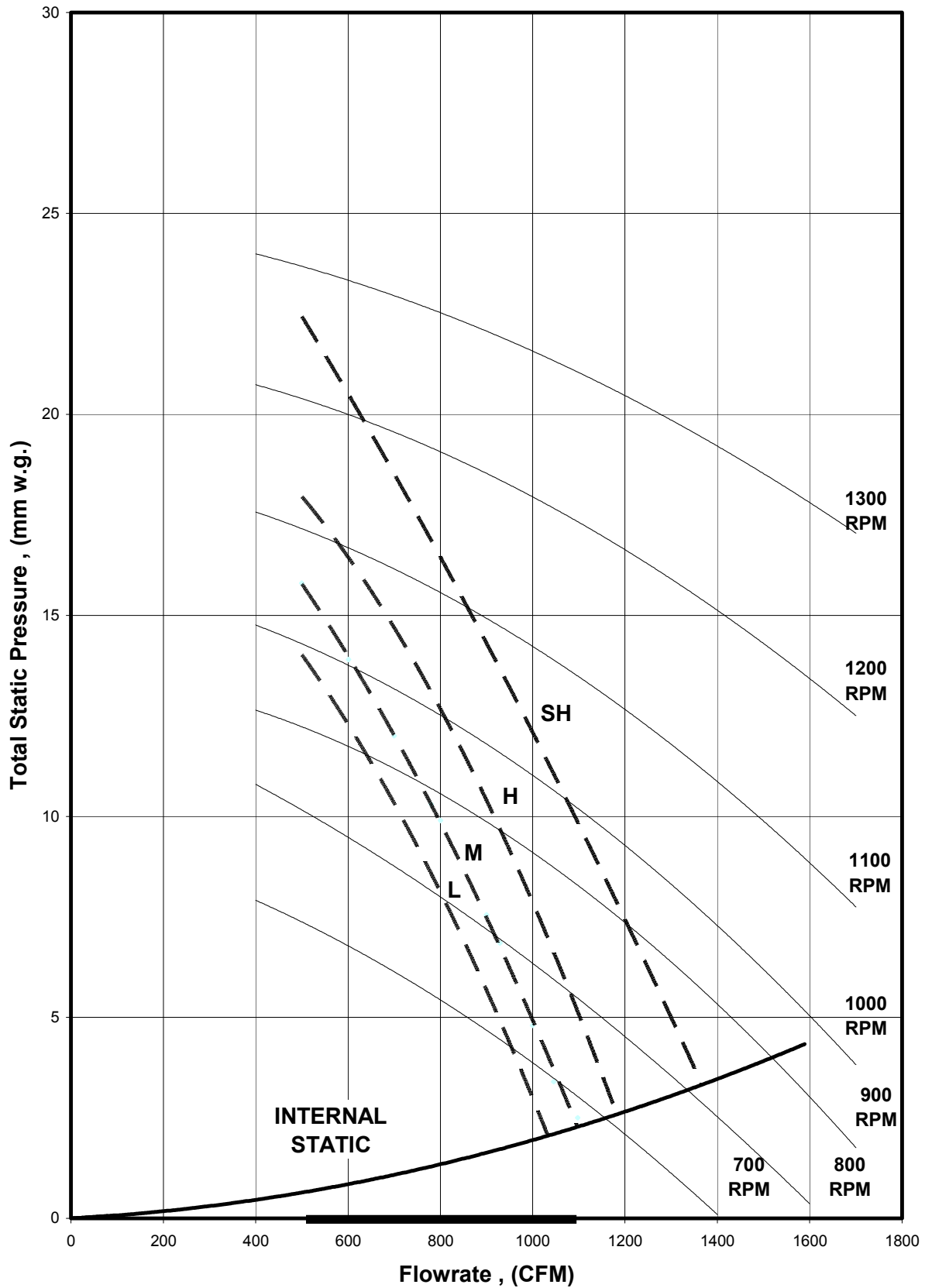

FAN PERFORMANCE CURVE MCC 050C/CR (Low Static Motor)

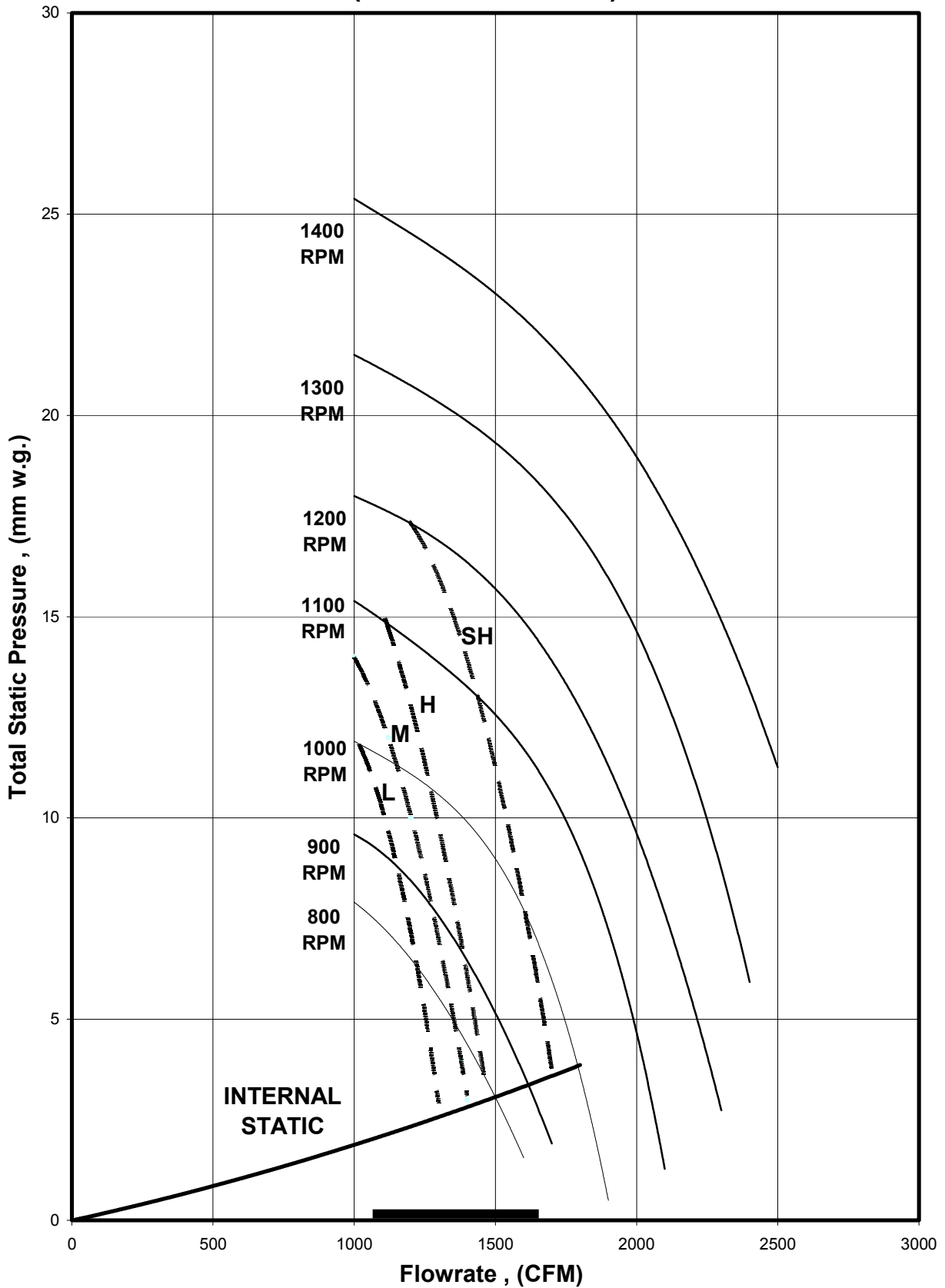

FAN PERFORMANCE CURVE MCC 060C/CR (Low Static Motor)

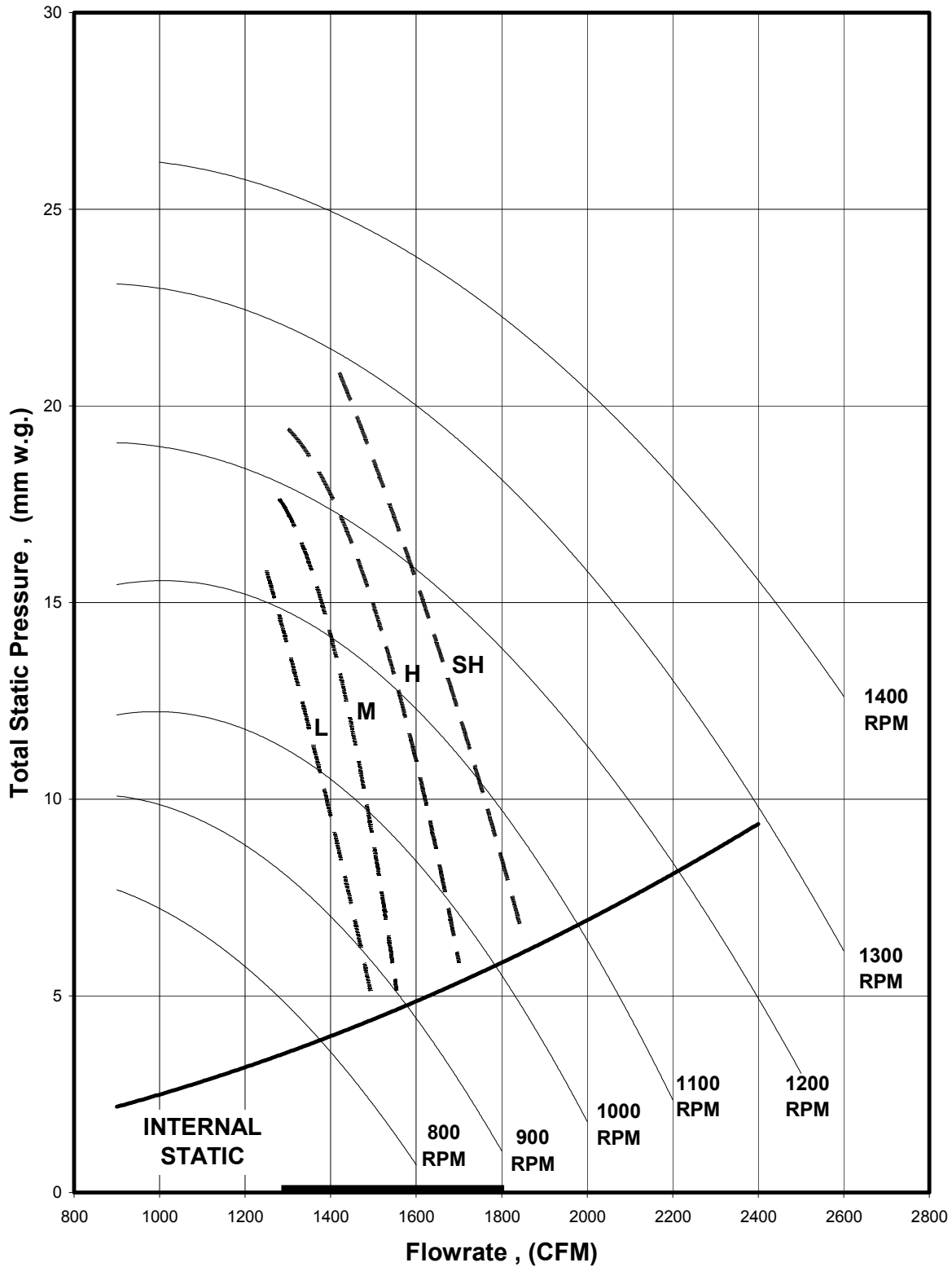

Engineering and Physical Data

General Data - Cooling Only (R22)

MODEL	INDOOR UNIT		MCC 010C	MCC 015C	
	OUTDOOR UNIT		MLC 010C	MLC 015C	
NOMINAL CAPACITY	Btu/h		9500	12300	
	W		2780	3600	
NOMINAL TOTAL INPUT POWER	W		900	1267	
NOMINAL RUNNING CURRENT	A		4.0	5.7	
POWER SOURCE	V/Ph/Hz		220 - 240 / 1 / 50	220 - 240 / 1 / 50	
EER	W/W		3.17	2.94	
REFRIGERANT TYPE			R22		
REFRIGERANT CONTROL (EXPANSION DEVICE)			OUTDOOR CAP. TUBE		
INDOOR UNIT	CONTROL	AIR DISCHARGE		DUCTED	
		OPERATION		SLM WIRED HANDSET	
	AIR FLOW	HIGH	l/s / CFM	142 / 300	241 / 510
		MEDIUM	l/s / CFM	123 / 260	208 / 440
		LOW	l/s / CFM	104 / 220	170 / 360
	EXTERNAL STATIC PRESSURE (H/M/L)		Pa (in.wg.)	49 / 39 / 29 (0.2 / 0.2 / 0.1)	49 / 39 / 20 (0.2 / 0.2 / 0.1)
	SOUND PRESSURE LEVEL (H/M/L)		dBA	33 / 30 / 26	37 / 34 / 29
	UNIT DIMENSION	HEIGHT	mm/in	261 / 10.3	261 / 10.3
		WIDTH	mm/in	765 / 30.1	905 / 35.6
		DEPTH	mm/in	411 / 16.2	411 / 16.2
	PACKING DIMENSION	HEIGHT	mm/in	376 / 14.8	376 / 14.8
		WIDTH	mm/in	951 / 37.4	1091 / 43.0
		DEPTH	mm/in	541 / 21.3	541 / 21.3
	WEIGHT		kg/lb	17 / 38	21 / 46
CONDENSATE DRAIN SIZE		mm/in	19.1 / 3/4		
AIR FLOW		l/s / CFM	396 / 840	453 / 960	
SOUND PRESSURE LEVEL		dBA	46	49	
UNIT DIMENSION	HEIGHT	mm/in	540 / 21.3		
	WIDTH	mm/in	700 / 27.6		
	DEPTH	mm/in	250 / 9.8		
PACKING DIMENSION	HEIGHT	mm/in	620 / 24.4		
	WIDTH	mm/in	810 / 31.9		
	DEPTH	mm/in	330 / 13.0		
UNIT WEIGHT		kg/lb	32 / 71		
PIPE CONNECTION	TYPE		FLARE VALVE		
	SIZE	LIQUID	mm/in	6.4 / 1/4	6.4 / 1/4
		GAS	mm/in	9.5 / 3/8	12.7 / 1/2
REFRIGERANT CHARGE		kg/lb	0.63 / 1.39	0.60 / 1.32	

- 1) ALL SPECIFICATIONS ARE SUBJECTED TO CHANGE BY THE MANUFACTURER WITHOUT PRIOR NOTICE.
- 2) ALL UNITS ARE BEING TESTED AND COMPLY TO ISO 5151.
- 3) NOMINAL COOLING AND HEATING CAPACITY ARE BASED ON THE CONDITIONS BELOW :
COOLING - 27°C DB / 19°C WB INDOOR AND 35°C DB / 24°C WB OUTDOOR
- 4) EER/COP CALCULATION IS BASED ON EFFECTIVE POWER INPUT AS PER ISO 5151.

General Data - Cooling Only (R22)

MODEL	INDOOR UNIT		MCC 020C		
	OUTDOOR UNIT		MLC 018C	MLC 020C	
NOMINAL CAPACITY	Btu/h		18000	19000	
	W		5280	5570	
NOMINAL TOTAL INPUT POWER	W		1910	1895	
NOMINAL RUNNING CURRENT	A		8.5	8.3	
POWER SOURCE	V/Ph/Hz		220 - 240 / 1 / 50	220 - 240 / 1 / 50	
EER	W/W		2.87	3.05	
REFRIGERANT TYPE	R22				
REFRIGERANT CONTROL (EXPANSION DEVICE)	OUTDOOR CAP. TUBE				
INDOOR UNIT	CONTROL	AIR DISCHARGE		DUCTED	
		OPERATION		SLM WIRED HANDSET	
	AIR FLOW	HIGH	l/s / CFM	316 / 670	
		MEDIUM	l/s / CFM	302 / 640	
		LOW	l/s / CFM	278 / 590	
	EXTERNAL STATIC PRESSURE (H/M/L)	Pa (in.wg.)	69 / 65 / 42 (0.28 / 0.26 / 0.17)		
	SOUND PRESSURE LEVEL (H/M/L)	dBA	38 / 36 / 34		
	UNIT DIMENSION	HEIGHT	mm/in	261 / 10.3	
		WIDTH	mm/in	1065 / 41.9	
		DEPTH	mm/in	411 / 16.2	
	PACKING DIMENSION	HEIGHT	mm/in	376 / 14.8	
		WIDTH	mm/in	1251 / 49.3	
		DEPTH	mm/in	541 / 21.3	
	WEIGHT	kg/lb	22 / 49		
CONDENSATE DRAIN SIZE	mm/in	19.1 / 3/4			
OUTDOOR UNIT	AIR FLOW	l/s / CFM	614 / 1300		
	SOUND PRESSURE LEVEL	dBA	51		
	UNIT DIMENSION	HEIGHT	mm/in	648 / 25.5	
		WIDTH	mm/in	855 / 33.7	
		DEPTH	mm/in	328 / 12.9	
	PACKING DIMENSION	HEIGHT	mm/in	710 / 28.0	
		WIDTH	mm/in	990 / 39.0	
		DEPTH	mm/in	415 / 16.3	
	UNIT WEIGHT	kg/lb	58 / 128	59 / 130	
	PIPE CONNECTION	SIZE	TYPE		FLARE VALVE
LIQUID			mm/in	6.4 / 1/4	
GAS			mm/in	15.9 / 5/8	
REFRIGERANT CHARGE	kg/lb	1.60 / 3.53	1.35 / 2.98		

1) ALL SPECIFICATIONS ARE SUBJECTED TO CHANGE BY THE MANUFACTURER WITHOUT PRIOR NOTICE.

2) ALL UNITS ARE BEING TESTED AND COMPLY TO ISO 5151.

3) NOMINAL COOLING AND HEATING CAPACITY ARE BASED ON THE CONDITIONS BELOW :
COOLING - 27°C DB / 19°C WB INDOOR AND 35°C DB / 24°C WB OUTDOOR

4) EER/COP CALCULATION IS BASED ON EFFECTIVE POWER INPUT AS PER ISO 5151.

General Data - Cooling Only (R22)

MODEL	INDOOR UNIT		MCC 025C		
	OUTDOOR UNIT		MLC 025C		
NOMINAL CAPACITY	Btu/h		23500		
	W		6890		
NOMINAL TOTAL INPUT POWER	W		2616		
NOMINAL RUNNING CURRENT	A		11.7		
POWER SOURCE	V/Ph/Hz		220 - 240 / 1 / 50		
EER	W/W		2.69		
REFRIGERANT TYPE			R22		
REFRIGERANT CONTROL (EXPANSION DEVICE)			OUTDOOR CAP. TUBE		
INDOOR UNIT	CONTROL	AIR DISCHARGE		DUCTED	
		OPERATION		SLM WIRED HANDSET	
	AIR FLOW	HIGH	l/s / CFM	382 / 810	
		MEDIUM	l/s / CFM	59 / 760	
		LOW	l/s / CFM	288 / 610	
	EXTERNAL STATIC PRESSURE (H/M/L)	Pa (in.wg.)	41 / 31 / 18 (0.16 / 0.12 / 0.07)		
	SOUND PRESSURE LEVEL (H/M/L)	dBA	40 / 39 / 36		
	UNIT DIMENSION	HEIGHT	mm/in	261 / 10.3	
		WIDTH	mm/in	1200 / 47.2	
		DEPTH	mm/in	411 / 16.2	
	PACKING DIMENSION	HEIGHT	mm/in	376 / 14.8	
		WIDTH	mm/in	1386 / 54.6	
		DEPTH	mm/in	541 / 21.3	
	WEIGHT	kg/lb	25 / 55		
CONDENSATE DRAIN SIZE	mm/in	19.1 / 3/4			
OUTDOOR UNIT	AIR FLOW	l/s / CFM	755 / 1600		
	SOUND PRESSURE LEVEL	dBA	52		
	UNIT DIMENSION	HEIGHT	mm/in	750 / 29.5	
		WIDTH	mm/in	855 / 33.7	
		DEPTH	mm/in	328 / 12.9	
	PACKING DIMENSION	HEIGHT	mm/in	810 / 31.9	
		WIDTH	mm/in	990 / 39.0	
		DEPTH	mm/in	415 / 16.3	
	UNIT WEIGHT	kg/lb	62 / 137		
	PIPE CONNECTION	TYPE		FLARE VALVE	
		SIZE	LIQUID	mm/in	9.5 / 3/8
GAS			mm/in	15.9 / 5/8	
REFRIGERANT CHARGE	kg/lb	1.50 / 3.31			

1) ALL SPECIFICATIONS ARE SUBJECTED TO CHANGE BY THE MANUFACTURER WITHOUT PRIOR NOTICE.
2) ALL UNITS ARE BEING TESTED AND COMPLY TO ISO 5151.

3) NOMINAL COOLING AND HEATING CAPACITY ARE BASED ON THE CONDITIONS BELOW:
COOLING - 27°C DB / 19°C WB INDOOR AND 35°C DB / 24°C WB OUTDOOR

4) EER/COP CALCULATION IS BASED ON EFFECTIVE POWER INPUT AS PER ISO 5151.

General Data - Cooling Only (R22)

MODEL	INDOOR UNIT		MCC 028C		
	OUTDOOR UNIT		MLC 028C	MLC 030C	
NOMINAL CAPACITY - 1Ø / <3Ø>	Btu/h		27000	28000 / <28000>	
	W		7910	8210 / <8210>	
NOMINAL TOTAL INPUT POWER - 1Ø / <3Ø>	W		3091	2821 / <2981>	
NOMINAL RUNNING CURRENT - 1Ø / <3Ø>	A		15.1	12.92 / <4.17>	
POWER SOURCE - 1Ø / <3Ø>	V/Ph/Hz		220 - 240 / 1 / 50 / <380 - 415 / 3 / 50>		
EER - 1Ø / <3Ø>	W/W		2.64	3.01 / <2.85>	
REFRIGERANT TYPE			R22		
REFRIGERANT CONTROL (EXPANSION DEVICE)			INDOOR CAP. TUBE		
INDOOR UNIT	CONTROL	AIR DISCHARGE		DUCTED	
		OPERATION		SLM WIRED HANDSET	
	AIR FLOW	SUPER HIGH	l/s / CFM	401 / 850	
		HIGH	l/s / CFM	382 / 810	
		MEDIUM	l/s / CFM	363 / 770	
		LOW	l/s / CFM	335 / 710	
	EXTERNAL STATIC PRESSURE (SH/H/M/L)	Pa (in.wg.)	98 / 78 / 68 / 59 (0.39 / 0.31 / 0.28 / 0.24)		
	SOUND PRESSURE LEVEL (SH/H/M/L)	dB(A)	44 / 41 / 38 / 34		
	UNIT DIMENSION	HEIGHT	mm/in	285 / 11.2	
		WIDTH	mm/in	1007 / 39.7	
		DEPTH	mm/in	600 / 23.6	
	PACKING DIMENSION	HEIGHT	mm/in	343 / 13.5	
		WIDTH	mm/in	1138 / 44.8	
		DEPTH	mm/in	690 / 27.2	
	WEIGHT	kg/lb	38 / 84		
CONDENSATE DRAIN SIZE	mm/in	19.1 / 3/4			
OUTDOOR UNIT	AIR FLOW	l/s / CFM	741 / 1570	1605 / 3400	
	SOUND PRESSURE LEVEL	dB(A)	54	58	
	UNIT DIMENSION	HEIGHT	mm/in	750 / 29.5	850 / 33.5
		WIDTH	mm/in	855 / 33.7	1030 / 40.6
		DEPTH	mm/in	328 / 12.9	400 / 15.8
	PACKING DIMENSION	HEIGHT	mm/in	810 / 31.9	1000 / 39.4
		WIDTH	mm/in	990 / 39.0	1200 / 47.2
		DEPTH	mm/in	415 / 16.3	560 / 22.1
	UNIT WEIGHT	kg/lb	68 / 150	95 / 209	
	PIPE CONNECTION	TYPE		FLARE VALVE	
		SIZE	LIQUID	mm/in	9.5 / 3/8
GAS			mm/in	15.9 / 5/8	
REFRIGERANT CHARGE	kg/lb	2.40 / 5.30	1.40 / 3.09		

- 1) ALL SPECIFICATIONS ARE SUBJECTED TO CHANGE BY THE MANUFACTURER WITHOUT PRIOR NOTICE.
- 2) ALL UNITS ARE BEING TESTED AND COMPLY TO ISO 5151.
- 3) NOMINAL COOLING AND HEATING CAPACITY ARE BASED ON THE CONDITIONS BELOW :
COOLING - 27°C DB / 19°C WB INDOOR AND 35°C DB / 24°C WB OUTDOOR
- 4) EER/COP CALCULATION IS BASED ON EFFECTIVE POWER INPUT AS PER ISO 5151.

General Data - Cooling Only (R22)

MODEL	INDOOR UNIT		MCC 030C		
	OUTDOOR UNIT		MLC 028C	MLC 030C	
NOMINAL CAPACITY - 1Ø / <3Ø>	Btu/h		28000	29000 / <29000>	
	W		8210	8490 / <8490>	
NOMINAL TOTAL INPUT POWER - 1Ø / <3Ø>	W		3153	2690 / <2760>	
NOMINAL RUNNING CURRENT - 1Ø / <3Ø>	A		15.50	13.1 / <5.49>	
POWER SOURCE - 1Ø / <3Ø>	V/Ph/Hz		220 - 240 / 1 / 50 / <380 - 415 / 3 / 50>		
EER - 1Ø / <3Ø>	W/W		2.80	3.29 / <3.22>	
REFRIGERANT TYPE	R22				
REFRIGERANT CONTROL (EXPANSION DEVICE)	INDOOR CAP. TUBE				
INDOOR UNIT	CONTROL	AIR DISCHARGE		DUCTED	
		OPERATION		SLM WIRED HANDSET	
	AIR FLOW	SUPER HIGH	l/s / CFM	425 / 900	
		HIGH	l/s / CFM	392 / 830	
		MEDIUM	l/s / CFM	359 / 760	
		LOW	l/s / CFM	335 / 710	
	EXTERNAL STATIC PRESSURE (SH/H/M/L)	Pa (in.wg.)	206 / 167 / 127 / 88 (0.83 / 0.67 / 0.51 / 0.35)		
	SOUND PRESSURE LEVEL (SH/H/M/L)	dBA	49 / 46 / 42 / 38		
	UNIT DIMENSION	HEIGHT	mm/in	378 / 14.9	
		WIDTH	mm/in	929 / 36.6	
		DEPTH	mm/in	541 / 21.3	
	PACKING DIMENSION	HEIGHT	mm/in	415 / 16.3	
		WIDTH	mm/in	1126 / 44.3	
		DEPTH	mm/in	631 / 24.8	
WEIGHT	kg/lb	39 / 86			
CONDENSATE DRAIN SIZE	mm/in	19.1 / 3/4			
OUTDOOR UNIT	AIR FLOW	l/s / CFM	741 / 1570	1605 / 3400	
	SOUND PRESSURE LEVEL	dBA	54	58	
	UNIT DIMENSION	HEIGHT	mm/in	750 / 29.5	850 / 33.5
		WIDTH	mm/in	855 / 33.7	1030 / 40.6
		DEPTH	mm/in	328 / 12.9	400 / 15.8
	PACKING DIMENSION	HEIGHT	mm/in	810 / 31.9	1000 / 39.4
		WIDTH	mm/in	990 / 39.0	1200 / 47.2
		DEPTH	mm/in	415 / 16.3	560 / 22.1
	UNIT WEIGHT	kg/lb	68 / 150	95 / 209	
	PIPE CONNECTION	TYPE		FLARE VALVE	
		SIZE	LIQUID	mm/in	
GAS			mm/in		
			9.5 / 3/8	15.9 / 5/8	
REFRIGERANT CHARGE	kg/lb		2.40 / 5.30	1.70 / 3.75	

1) ALL SPECIFICATIONS ARE SUBJECTED TO CHANGE BY THE MANUFACTURER WITHOUT PRIOR NOTICE.

2) ALL UNITS ARE BEING TESTED AND COMPLY TO ISO 5151.

3) NOMINAL COOLING AND HEATING CAPACITY ARE BASED ON THE CONDITIONS BELOW :
COOLING - 27°C DB / 19°C WB INDOOR AND 35°C DB / 24°C WB OUTDOOR

4) EER/COP CALCULATION IS BASED ON EFFECTIVE POWER INPUT AS PER ISO 5151.

General Data - Cooling Only (R22)

MODEL	INDOOR UNIT		MCC 038C		
	OUTDOOR UNIT		MLC 035C	MLC 040C	
NOMINAL CAPACITY - 1Ø / <3Ø>	Btu/h		35000	35000 / <35000>	
	W		10260	10260 / <10260>	
NOMINAL TOTAL INPUT POWER - 1Ø / <3Ø>	W		3443	3473 / <3443>	
NOMINAL RUNNING CURRENT - 1Ø / <3Ø>	A		16.52	27.12 / <14.44>	
POWER SOURCE - 1Ø / <3Ø>	V/Ph/Hz		220 - 240 / 1 / 50 / <380 - 415 / 3 / 50>		
EER - 1Ø / <3Ø>	W/W		3.23	2.99 / <3.03>	
REFRIGERANT TYPE			R22		
REFRIGERANT CONTROL (EXPANSION DEVICE)			INDOOR CAP. TUBE		
INDOOR UNIT	CONTROL	AIR DISCHARGE		DUCTED	
		OPERATION		SLM WIRED HANDSET	
	AIR FLOW	SUPER HIGH	l/s / CFM	727 / 1540	
		HIGH	l/s / CFM	694 / 1470	
		MEDIUM	l/s / CFM	670 / 1420	
		LOW	l/s / CFM	637 / 1350	
	EXTERNAL STATIC PRESSURE (SH/H/M/L)		Pa (in.wg.)	137 / 118 / 108 / 88 (0.55 / 0.47 / 0.43 / 0.35)	
	SOUND PRESSURE LEVEL (SH/H/M/L)		dBA	55 / 51 / 48 / 45	
	UNIT DIMENSION	HEIGHT	mm/in	305 / 12.0	
		WIDTH	mm/in	1302 / 51.3	
		DEPTH	mm/in	638 / 25.1	
	PACKING DIMENSION	HEIGHT	mm/in	355 / 14.0	
		WIDTH	mm/in	1461 / 57.5	
		DEPTH	mm/in	727 / 28.6	
	WEIGHT		kg/lb	41 / 90	
CONDENSATE DRAIN SIZE		mm/in	19.1 / 3/4		
OUTDOOR UNIT	AIR FLOW		l/s / CFM	1605 / 3400	1605 / 3400
	SOUND PRESSURE LEVEL		dBA	58	58
	UNIT DIMENSION	HEIGHT	mm/in	850 / 33.5	
		WIDTH	mm/in	1030 / 40.6	
		DEPTH	mm/in	400 / 15.8	
	PACKING DIMENSION	HEIGHT	mm/in	1000 / 39.4	
		WIDTH	mm/in	1200 / 47.2	
		DEPTH	mm/in	560 / 22.1	
	UNIT WEIGHT		kg/lb	95 / 209	100 / 221
	PIPE CONNECTION	TYPE		FLARE VALVE	
		SIZE	LIQUID	mm/in	9.5 / 3/8
GAS			mm/in	19.1 / 3/4	
REFRIGERANT CHARGE		kg/lb	1.85 / 4.08	2.10 / 4.63	

1) ALL SPECIFICATIONS ARE SUBJECTED TO CHANGE BY THE MANUFACTURER WITHOUT PRIOR NOTICE.

2) ALL UNITS ARE BEING TESTED AND COMPLY TO ISO 5151.

3) NOMINAL COOLING AND HEATING CAPACITY ARE BASED ON THE CONDITIONS BELOW:
COOLING - 27°C DB / 19°C WB INDOOR AND 35°C DB / 24°C WB OUTDOOR

4) EER/COP CALCULATION IS BASED ON EFFECTIVE POWER INPUT AS PER ISO 5151.

General Data - Cooling Only (R22)

MODEL	INDOOR UNIT		MCC 040C		
	OUTDOOR UNIT		MLC 035C	MLC 040C	
NOMINAL CAPACITY - 1Ø / <3Ø>	Btu/h		33500	38500 / <38500>	
	W		9810	11280 / <11280>	
NOMINAL TOTAL INPUT POWER - 1Ø / <3Ø>	W		3290	3420 / <3390>	
NOMINAL RUNNING CURRENT - 1Ø / <3Ø>	A		16.40	18.50 / <5.90>	
POWER SOURCE - 1Ø / <3Ø>	V/Ph/Hz		220 - 240 / 1 / 50 / <380 - 415 / 3 / 50>		
EER - 1Ø / <3Ø>	W/W		3.16	3.46 / <3.51>	
REFRIGERANT TYPE			R22		
REFRIGERANT CONTROL (EXPANSION DEVICE)			INDOOR CAP. TUBE		
INDOOR UNIT	CONTROL	AIR DISCHARGE		DUCTED	
		OPERATION		SLM WIRED HANDSET	
	AIR FLOW	SUPER HIGH	l/s / CFM	519 / 1100	
		HIGH	l/s / CFM	500 / 1060	
		MEDIUM	l/s / CFM	467 / 990	
		LOW	l/s / CFM	425 / 900	
	EXTERNAL STATIC PRESSURE (SH/H/M/L)		Pa (in.wg.)	206 / 176 / 127 / 93 (0.83 / 0.71 / 0.51 / 0.37)	
	SOUND PRESSURE LEVEL (SH/H/M/L)		dBA	51 / 49 / 45 / 41	
	UNIT DIMENSION	HEIGHT	mm/in	378 / 14.9	
		WIDTH	mm/in	1045 / 41.1	
		DEPTH	mm/in	541 / 21.3	
	PACKING DIMENSION	HEIGHT	mm/in	415 / 16.3	
		WIDTH	mm/in	1245 / 49.0	
		DEPTH	mm/in	631 / 24.8	
	WEIGHT		kg/lb	42 / 93	
CONDENSATE DRAIN SIZE		mm/in	19.1 / 3/4		
OUTDOOR UNIT	AIR FLOW		l/s / CFM	1605 / 3400	1605 / 3400
	SOUND PRESSURE LEVEL		dBA	58	58
	UNIT DIMENSION	HEIGHT	mm/in	850 / 33.5	
		WIDTH	mm/in	1030 / 40.6	
		DEPTH	mm/in	400 / 15.8	
	PACKING DIMENSION	HEIGHT	mm/in	1000 / 39.4	
		WIDTH	mm/in	1200 / 47.2	
		DEPTH	mm/in	560 / 22.1	
	UNIT WEIGHT		kg/lb	95 / 209	100 / 221
	PIPE CONNECTION	TYPE		FLARE VALVE	
SIZE		LIQUID	mm/in	9.5 / 3/8	
		GAS	mm/in	19.1 / 3/4	
REFRIGERANT CHARGE		kg/lb	1.90 / 4.19	2.40 / 5.29	

1) ALL SPECIFICATIONS ARE SUBJECTED TO CHANGE BY THE MANUFACTURER WITHOUT PRIOR NOTICE.

2) ALL UNITS ARE BEING TESTED AND COMPLY TO ISO 5151.

3) NOMINAL COOLING AND HEATING CAPACITY ARE BASED ON THE CONDITIONS BELOW:
COOLING - 27°C DB / 19°C WB INDOOR AND 35°C DB / 24°C WB OUTDOOR

4) EER/COP CALCULATION IS BASED ON EFFECTIVE POWER INPUT AS PER ISO 5151.

General Data - Cooling Only (R22)

MODEL	INDOOR UNIT		MCC 050C	MCC 060C	
	OUTDOOR UNIT		MLC 050C	MLC 061C	
NOMINAL CAPACITY	Btu/h		47000	56000	
	W		13770	16410	
NOMINAL TOTAL INPUT POWER	W		4810	6000	
NOMINAL RUNNING CURRENT	A		8.6	10.0	
POWER SOURCE	V/Ph/Hz		380 - 415 / 3 / 50	380 - 415 / 3 / 50	
EER	W/W		2.97	2.92	
REFRIGERANT TYPE			R22		
REFRIGERANT CONTROL (EXPANSION DEVICE)			INDOOR CAP. TUBE		
INDOOR UNIT	CONTROL	AIR DISCHARGE		DUCTED	
		OPERATION		SLM WIRED HANDSET	
	AIR FLOW	SUPER HIGH	l/s / CFM	750 / 1590	779 / 1650
		HIGH	l/s / CFM	651 / 1380	722 / 1530
		MEDIUM	l/s / CFM	604 / 1280	675 / 1430
		LOW	l/s / CFM	571 / 1210	609 / 1290
	EXTERNAL STATIC PRESSURE (SH/H/M/L)		Pa (in.wg.)	176 / 157 / 137 / 108 (0.7 / 0.6 / 0.6 / 0.4)	176 / 157 / 137 / 98 (0.7 / 0.6 / 0.6 / 0.4)
	SOUND PRESSURE LEVEL (SH/H/M/L)		dBA	53 / 52 / 50 / 47	55 / 53 / 50 / 47
	UNIT DIMENSION	HEIGHT	mm/in	378 / 14.9	378 / 14.9
		WIDTH	mm/in	1299 / 51.1	1499 / 59.0
		DEPTH	mm/in	541 / 21.3	541 / 21.3
	PACKING DIMENSION	HEIGHT	mm/in	415 / 16.3	415 / 16.3
		WIDTH	mm/in	1497 / 59.0	1701 / 67.0
		DEPTH	mm/in	631 / 24.8	631 / 24.8
	WEIGHT		kg/lb	54 / 119	62 / 137
CONDENSATE DRAIN SIZE		mm/in	19.1 / 3/4		
OUTDOOR UNIT	AIR FLOW		l/s / CFM	1605 / 3400	1793 / 3800
	SOUND PRESSURE LEVEL		dBA	58	61
	UNIT DIMENSION	HEIGHT	mm/in	850 / 33.5	850 / 33.5
		WIDTH	mm/in	1030 / 40.6	1030 / 40.6
		DEPTH	mm/in	400 / 15.8	460 / 18.1
	PACKING DIMENSION	HEIGHT	mm/in	1000 / 39.4	1016 / 40.0
		WIDTH	mm/in	1200 / 47.2	1178 / 46.4
		DEPTH	mm/in	560 / 22.1	602 / 23.7
	UNIT WEIGHT		kg/lb	105 / 232	108 / 238
	PIPE CONNECTION	TYPE		FLARE VALVE	
SIZE		LIQUID	mm/in	9.5 / 3/8	12.7 / 1/2
		GAS	mm/in	19.1 / 3/4	19.1 / 3/4
REFRIGERANT CHARGE		kg/lb	3.15 / 6.94	5.00 / 11.02	

1) ALL SPECIFICATIONS ARE SUBJECTED TO CHANGE BY THE MANUFACTURER WITHOUT PRIOR NOTICE.

2) ALL UNITS ARE BEING TESTED AND COMPLY TO ISO 5151.

3) NOMINAL COOLING AND HEATING CAPACITY ARE BASED ON THE CONDITIONS BELOW :

COOLING - 27°C DB / 19°C WB INDOOR AND 35°C DB / 24°C WB OUTDOOR

4) EER/COP CALCULATION IS BASED ON EFFECTIVE POWER INPUT AS PER ISO 5151.

General Data - Heat pump (R22)

MODEL	INDOOR UNIT		MCC 010CR	MCC 015CR	
	OUTDOOR UNIT		MLC 010CR	MLC 015CR	
NOMINAL COOLING CAPACITY	Btu/h		9500	12300	
	W		2780	3600	
NOMINAL HEATING CAPACITY	Btu/h		9500	12300	
	W		2780	3600	
NOMINAL TOTAL INPUT POWER (COOLING)	W		900	1267	
NOMINAL TOTAL INPUT POWER (HEATING)	W		790	1062	
NOMINAL RUNNING CURRENT (COOLING)	A		4.0	5.7	
NOMINAL RUNNING CURRENT (HEATING)	A		3.5	4.8	
POWER SOURCE	V/Ph/Hz		220 - 240 / 1 / 50	220 - 240 / 1 / 50	
EER	W/W		3.17	2.94	
COP	W/W		3.63	3.44	
REFRIGERANT TYPE			R22		
REFRIGERANT CONTROL (EXPANSION DEVICE)			OUTDOOR CAP. TUBE		
INDOOR UNIT	CONTROL	AIR DISCHARGE		DUCTED	
		OPERATION		SLM WIRED HANDSET	
	AIR FLOW	HIGH	l/s / CFM	142 / 300	241 / 510
		MEDIUM	l/s / CFM	123 / 260	208 / 440
		LOW	l/s / CFM	104 / 220	170 / 360
	EXTERNAL STATIC PRESSURE (H/M/L)		Pa (in.wg.)	49 / 39 / 29 (0.2 / 0.2 / 0.1)	49 / 39 / 20 (0.2 / 0.2 / 0.1)
	SOUND PRESSURE LEVEL (H/M/L)		dBA	33 / 30 / 26	37 / 34 / 29
	UNIT DIMENSION	HEIGHT	mm/in	261 / 10.3	261 / 10.3
		WIDTH	mm/in	765 / 30.1	905 / 35.6
		DEPTH	mm/in	411 / 16.2	411 / 16.2
	PACKING DIMENSION	HEIGHT	mm/in	376 / 14.8	376 / 14.8
		WIDTH	mm/in	951 / 37.4	1091 / 43.0
		DEPTH	mm/in	541 / 21.3	541 / 21.3
	WEIGHT		kg/lb	17 / 38	21 / 46.3
	CONDENSATE DRAIN SIZE		mm/in	19.1 / 3/4	
AIR FLOW		l/s / CFM	396 / 840	453 / 960	
SOUND PRESSURE LEVEL		dBA	46	49	
UNIT DIMENSION	HEIGHT	mm/in	540 / 21.3		
	WIDTH	mm/in	700 / 27.6		
	DEPTH	mm/in	250 / 9.8		
PACKING DIMENSION	HEIGHT	mm/in	620 / 24.4		
	WIDTH	mm/in	810 / 31.9		
	DEPTH	mm/in	330 / 13.0		
UNIT WEIGHT		kg/lb	32 / 71		
PIPE CONNECTION	SIZE	TYPE		FLARE VALVE	
		LIQUID	mm/in	6.4 / 1/4	6.4 / 1/4
		GAS	mm/in	9.5 / 3/8	12.7 / 1/2
REFRIGERANT CHARGE		kg/lb	0.63 / 1.39	0.60 / 1.32	

1) ALL SPECIFICATIONS ARE SUBJECTED TO CHANGE BY THE MANUFACTURER WITHOUT PRIOR NOTICE.

2) ALL UNITS ARE BEING TESTED AND COMPLY TO ISO 5151.

3) NOMINAL COOLING AND HEATING CAPACITY ARE BASED ON THE CONDITIONS BELOW :
COOLING - 27°C DB / 19°C WB INDOOR AND 35°C DB / 24°C WB OUTDOOR

4) EER/COP CALCULATION IS BASED ON EFFECTIVE POWER INPUT AS PER ISO 5151.

General Data - Heat pump (R22)

MODEL	INDOOR UNIT		MCC 020CR		
	OUTDOOR UNIT		MLC 018CR	MLC 020CR	
NOMINAL COOLING CAPACITY	Btu/h		18000	19000	
	W		5280	5570	
NOMINAL HEATING CAPACITY	Btu/h		18500	19800	
	W		5420	5800	
NOMINAL TOTAL INPUT POWER (COOLING)	W		1910	1895	
NOMINAL TOTAL INPUT POWER (HEATING)	W		1750	1845	
NOMINAL RUNNING CURRENT (COOLING)	A		8.5	8.3	
NOMINAL RUNNING CURRENT (HEATING)	A		7.8	8.1	
POWER SOURCE	V/Ph/Hz		220 - 240 / 1 / 50	220 - 240 / 1 / 50	
EER	W/W		2.87	3.05	
COP	W/W		3.23	3.27	
REFRIGERANT TYPE			R22		
REFRIGERANT CONTROL (EXPANSION DEVICE)			OUTDOOR CAP. TUBE		
INDOOR UNIT	CONTROL	AIR DISCHARGE		DUCTED	
		OPERATION		SLM WIRED HANDSET	
	AIR FLOW	HIGH	l/s / CFM	316 / 670	
		MEDIUM	l/s / CFM	302 / 640	
		LOW	l/s / CFM	278 / 590	
	EXTERNAL STATIC PRESSURE (H/M/L)		Pa (in.wg.)	69 / 65 / 42 (0.28 / 0.26 / 0.17)	
	SOUND PRESSURE LEVEL (H/M/L)		dBA	38 / 36 / 34	
	UNIT DIMENSION	HEIGHT	mm/in	261 / 10.3	
		WIDTH	mm/in	1065 / 41.9	
		DEPTH	mm/in	411 / 16.2	
	PACKING DIMENSION	HEIGHT	mm/in	376 / 14.8	
		WIDTH	mm/in	1251 / 49.3	
		DEPTH	mm/in	541 / 21.3	
	WEIGHT		kg/lb	22 / 49	
CONDENSATE DRAIN SIZE		mm/in	19.1 / 3/4		
OUTDOOR UNIT	AIR FLOW		l/s / CFM	614 / 1300	
	SOUND PRESSURE LEVEL		dBA	51	
	UNIT DIMENSION	HEIGHT	mm/in	648 / 25.5	
		WIDTH	mm/in	855 / 33.7	
		DEPTH	mm/in	328 / 12.9	
	PACKING DIMENSION	HEIGHT	mm/in	810 / 31.9	
		WIDTH	mm/in	990 / 39.0	
		DEPTH	mm/in	415 / 16.3	
	UNIT WEIGHT		kg/lb	58 / 128	59 / 130
	PIPE CONNECTION	TYPE		FLARE VALVE	
SIZE		LIQUID	mm/in	6.4 / 1/4	
		GAS	mm/in	15.9 / 5/8	
REFRIGERANT CHARGE		kg/lb	1.60 / 3.53	1.35 / 2.98	

- 1) ALL SPECIFICATIONS ARE SUBJECTED TO CHANGE BY THE MANUFACTURER WITHOUT PRIOR NOTICE.
- 2) ALL UNITS ARE BEING TESTED AND COMPLY TO ISO 5151.
- 3) NOMINAL COOLING AND HEATING CAPACITY ARE BASED ON THE CONDITIONS BELOW :
 - a) COOLING - 27°C DB / 19°C WB INDOOR AND 35°C DB / 24°C WB OUTDOOR
 - b) HEATING - 20°C DB INDOOR AND 7°C DB / 6°C WB OUTDOOR
- 4) EER/COP CALCULATION IS BASED ON EFFECTIVE POWER INPUT AS PER ISO 5151.

General Data - Heat pump (R22)

MODEL	INDOOR UNIT		MCC 025CR		
	OUTDOOR UNIT		MLC 025CR		
NOMINAL COOLING CAPACITY	Btu/h		23500		
	W		6890		
NOMINAL HEATING CAPACITY	Btu/h		24000		
	W		7030		
NOMINAL TOTAL INPUT POWER (COOLING)	W		2616		
NOMINAL TOTAL INPUT POWER (HEATING)	W		2536		
NOMINAL RUNNING CURRENT (COOLING)	A		11.7		
NOMINAL RUNNING CURRENT (HEATING)	A		11.5		
POWER SOURCE	V/Ph/Hz		220 - 240 / 1 / 50		
EER	W/W		2.69		
COP	W/W		2.83		
REFRIGERANT TYPE			R22		
REFRIGERANT CONTROL (EXPANSION DEVICE)			OUTDOOR CAP. TUBE		
INDOOR UNIT	CONTROL	AIR DISCHARGE		DUCTED	
		OPERATION		SLM WIRED HANDSET	
	AIR FLOW	HIGH	l/s / CFM	382 / 810	
		MEDIUM	l/s / CFM	359 / 760	
		LOW	l/s / CFM	288 / 610	
	EXTERNAL STATIC PRESSURE (H/M/L)	Pa (in.wg.)	41 / 31 / 18 (0.16 / 0.12 / 0.07)		
	SOUND PRESSURE LEVEL (H/M/L)	dBA	40 / 39 / 36		
	UNIT DIMENSION	HEIGHT	mm/in	261 / 10.3	
		WIDTH	mm/in	1200 / 47.2	
		DEPTH	mm/in	411 / 16.2	
	PACKING DIMENSION	HEIGHT	mm/in	376 / 14.8	
		WIDTH	mm/in	1386 / 54.6	
		DEPTH	mm/in	541 / 21.3	
	WEIGHT	kg/lb	25 / 55		
	CONDENSATE DRAIN SIZE	mm/in	19.1 / 3/4		
OUTDOOR UNIT	AIR FLOW	l/s / CFM	755 / 1600		
	SOUND PRESSURE LEVEL	dBA	52		
	UNIT DIMENSION	HEIGHT	mm/in	750 / 29.5	
		WIDTH	mm/in	855 / 33.7	
		DEPTH	mm/in	328 / 12.9	
	PACKING DIMENSION	HEIGHT	mm/in	810 / 31.9	
		WIDTH	mm/in	990 / 39.0	
		DEPTH	mm/in	415 / 16.3	
	UNIT WEIGHT	kg/lb	62 / 137		
	PIPE CONNECTION	SIZE	TYPE		FLARE VALVE
LIQUID			mm/in	9.5 / 3/8	
GAS			mm/in	15.9 / 5/8	
REFRIGERANT CHARGE	kg/lb	1.50 / 3.31			

1) ALL SPECIFICATIONS ARE SUBJECTED TO CHANGE BY THE MANUFACTURER WITHOUT PRIOR NOTICE.

2) ALL UNITS ARE BEING TESTED AND COMPLY TO ISO 5151.

3) NOMINAL COOLING AND HEATING CAPACITY ARE BASED ON THE CONDITIONS BELOW :

a) COOLING - 27°C DB / 19°C WB INDOOR AND 35°C DB / 24°C WB OUTDOOR

b) HEATING - 20°C DB INDOOR AND 7°C DB / 6°C WB OUTDOOR

4) EER/COP CALCULATION IS BASED ON EFFECTIVE POWER INPUT AS PER ISO 5151.

General Data - Heat pump (R22)

MODEL	INDOOR UNIT		MCC 028CR		
	OUTDOOR UNIT		MLC 028CR	MLC 030CR	
NOMINAL COOLING CAPACITY - 1Ø / <3Ø>	Btu/h		27000	30000 / <30000>	
	W		7910	8790 / <8790>	
NOMINAL HEATING CAPACITY - 1Ø / <3Ø>	Btu/h		28000	30000 / <30000>	
	W		8210	8790 / <8790>	
NOMINAL TOTAL INPUT POWER (COOLING) - 1Ø / <3Ø>	W		3091	3090 / <3070>	
NOMINAL TOTAL INPUT POWER (HEATING) - 1Ø / <3Ø>	W		2638	3060 / <3040>	
NOMINAL RUNNING CURRENT (COOLING) - 1Ø / <3Ø>	A		15.1	14.7 / <5.1>	
NOMINAL RUNNING CURRENT (HEATING) - 1Ø / <3Ø>	A		13.4	14.6 / <5.0>	
POWER SOURCE - 1Ø / <3Ø>	V/Ph/Hz		220 - 240 / 1 / 50 / <380 - 415 / 3 / 50>		
EER - 1Ø / <3Ø>	W/W		2.64	2.94 / <2.86>	
COP - 1Ø / <3Ø>	W/W		3.23	2.97 / <2.99>	
REFRIGERANT TYPE / CONTROL			R22	R22	
REFRIGERANT CONTROL (EXPANSION DEVICE)			OUTDOOR CAP. TUBE	OUTDOOR CAP. TUBE + TXV	
INDOOR UNIT	CONTROL	AIR DISCHARGE		DUCTED	
		OPERATION		SLM WIRED HANDSET	
	AIR FLOW	SUPER HIGH	l/s / CFM	401 / 850	
		HIGH	l/s / CFM	382 / 810	
		MEDIUM	l/s / CFM	363 / 770	
		LOW	l/s / CFM	335 / 710	
	EXTERNAL STATIC PRESSURE (H/M/L)		Pa (in.wg.)	98 / 78 / 68 / 59 (0.4 / 0.3 / 0.3 / 0.2)	
	SOUND PRESSURE LEVEL (H/M/L)		dBA	44 / 41 / 38 / 34	
	UNIT DIMENSION	HEIGHT	mm/in	285 / 11.2	
		WIDTH	mm/in	1007 / 39.7	
		DEPTH	mm/in	600 / 23.6	
	PACKING DIMENSION	HEIGHT	mm/in	343 / 13.5	
		WIDTH	mm/in	1138 / 44.8	
		DEPTH	mm/in	690 / 27.2	
	WEIGHT		kg/lb	38 / 84	
CONDENSATE DRAIN SIZE		mm/in	19.1 / 3/4		
OUTDOOR UNIT	AIR FLOW		l/s / CFM	741 / 1570	1605 / 3400
	SOUND PRESSURE LEVEL		dBA	54	58
	UNIT DIMENSION	HEIGHT	mm/in	750 / 29.5	850 / 33.5
		WIDTH	mm/in	855 / 33.7	1030 / 40.6
		DEPTH	mm/in	328 / 12.9	400 / 15.8
	PACKING DIMENSION	HEIGHT	mm/in	810 / 31.9	1000 / 39.4
		WIDTH	mm/in	990 / 39.0	1200 / 47.2
		DEPTH	mm/in	415 / 16.3	560 / 22.1
	UNIT WEIGHT		kg/lb	68 / 150	95 / 209
	PIPE CONNECTION	TYPE		FLARE VALVE	
SIZE		LIQUID	mm/in	9.5 / 3/8	
		GAS	mm/in	15.9 / 5/8	
REFRIGERANT CHARGE		kg/lb	2.40 / 5.30	2.15 / 4.74	

- 1) ALL SPECIFICATIONS ARE SUBJECTED TO CHANGE BY THE MANUFACTURER WITHOUT PRIOR NOTICE.
- 2) ALL UNITS ARE BEING TESTED AND COMPLY TO ISO 5151.
- 3) NOMINAL COOLING AND HEATING CAPACITY ARE BASED ON THE CONDITIONS BELOW :
 - a) COOLING - 27°C DB / 19°C WB INDOOR AND 35°C DB / 24°C WB OUTDOOR
 - b) HEATING - 20°C DB INDOOR AND 7°C DB / 6°C WB OUTDOOR
- 4) EER/COP CALCULATION IS BASED ON EFFECTIVE POWER INPUT AS PER ISO 5151.

General Data - Heat pump (R22)

MODEL	INDOOR UNIT		MCC 030CR		
	OUTDOOR UNIT		MLC 028CR	MLC 030CR	
NOMINAL COOLING CAPACITY- 1Ø / <3Ø>	Btu/h		28000	30000 / <30000>	
	W		8600	8790 / <8790>	
NOMINAL HEATING CAPACITY- 1Ø / <3Ø>	Btu/h		29000	30000 / <30000>	
	W		8500	8790 / <8790>	
NOMINAL TOTAL INPUT POWER (COOLING) - 1Ø / <3Ø>	W		3153	3145 / <3125>	
NOMINAL TOTAL INPUT POWER (HEATING) - 1Ø / <3Ø>	W		2729	3115 / <3095>	
NOMINAL RUNNING CURRENT (COOLING) - 1Ø / <3Ø>	A		15.5	15.0 / <5.2>	
NOMINAL RUNNING CURRENT (HEATING) - 1Ø / <3Ø>	A		13.8	14.9 / <5.1>	
POWER SOURCE - 1Ø / <3Ø>	V/Ph/Hz		220 - 240 / 1 / 50 / <380 - 415 / 3 / 50>		
EER - 1Ø / <3Ø>	W/W		3.09	3.00 / <3.02>	
COP - 1Ø / <3Ø>	W/W		3.62	3.03 / <3.06>	
REFRIGERANT TYPE / CONTROL			R22	R22	
REFRIGERANT CONTROL (EXPANSION DEVICE)			OUTDOOR CAP. TUBE	OUTDOOR CAP. TUBE + TXV	
INDOOR UNIT	CONTROL	AIR DISCHARGE		DUCTED	
		OPERATION		SLM WIRED HANDSET	
	AIR FLOW	SUPER HIGH	l/s / CFM	425 / 900	
		HIGH	l/s / CFM	392 / 830	
		MEDIUM	l/s / CFM	359 / 760	
		LOW	l/s / CFM	335 / 710	
	EXTERNAL STATIC PRESSURE (H/M/L)		Pa (in.wg.)	206 / 167 / 127 / 88 (0.8 / 0.7 / 0.5 / 0.4)	
	SOUND PRESSURE LEVEL (H/M/L)		dBA	49 / 46 / 42 / 38	
	UNIT DIMENSION	HEIGHT	mm/in	378 / 14.9	
		WIDTH	mm/in	929 / 36.6	
		DEPTH	mm/in	541 / 21.3	
	PACKING DIMENSION	HEIGHT	mm/in	415 / 16.3	
		WIDTH	mm/in	1126 / 44.3	
		DEPTH	mm/in	631 / 24.8	
	WEIGHT		kg/lb	39 / 86	
CONDENSATE DRAIN SIZE		mm/in	19.1 / 3/4		
OUTDOOR UNIT	AIR FLOW		l/s / CFM	741 / 1570	1605 / 3400
	SOUND PRESSURE LEVEL		dBA	54	58
	UNIT DIMENSION	HEIGHT	mm/in	750 / 29.5	850 / 33.46
		WIDTH	mm/in	855 / 33.7	1030 / 40.55
		DEPTH	mm/in	328 / 12.9	400 / 15.75
	PACKING DIMENSION	HEIGHT	mm/in	810 / 31.9	1000 / 39.37
		WIDTH	mm/in	990 / 39.0	1200 / 47.24
		DEPTH	mm/in	415 / 16.3	560 / 22.05
	UNIT WEIGHT		kg/lb	68 / 150	95 / 209
	PIPE CONNECTION	TYPE		FLARE VALVE	
SIZE		LIQUID	mm/in	9.5 / 3/8	
		GAS	mm/in	15.9 / 5/8	
REFRIGERANT CHARGE			kg/lb	2.40 / 5.30	2.15 / 4.74

1) ALL SPECIFICATIONS ARE SUBJECTED TO CHANGE BY THE MANUFACTURER WITHOUT PRIOR NOTICE.

2) ALL UNITS ARE BEING TESTED AND COMPLY TO ISO 5151.

3) NOMINAL COOLING AND HEATING CAPACITY ARE BASED ON THE CONDITIONS BELOW :

a) COOLING - 27°C DB / 19°C WB INDOOR AND 35°C DB / 24°C WB OUTDOOR

b) HEATING - 20°C DB INDOOR AND 7°C DB / 6°C WB OUTDOOR

4) EER/COP CALCULATION IS BASED ON EFFECTIVE POWER INPUT AS PER ISO 5151.

General Data - Heat pump (R22)

MODEL	INDOOR UNIT		MCC 038CR		
	OUTDOOR UNIT		MLC 035CR	MLC 040CR	
NOMINAL COOLING CAPACITY- 1Ø / <3Ø>	Btu/h		35000	38000 / <38000>	
	W		10260	11140 / <11140>	
NOMINAL HEATING CAPACITY- 1Ø / <3Ø>	Btu/h		36000	38500 / <38500>	
	W		10550	11280 / <11280>	
NOMINAL TOTAL INPUT POWER (COOLING) - 1Ø / <3Ø>	W		3303	3766 / <3736>	
NOMINAL TOTAL INPUT POWER (HEATING) - 1Ø / <3Ø>	W		3303	3476 / <3436>	
NOMINAL RUNNING CURRENT (COOLING) - 1Ø / <3Ø>	A		16.5	18.1 / <5.4>	
NOMINAL RUNNING CURRENT (HEATING) - 1Ø / <3Ø>	A		16.5	16.7 / <3.0>	
POWER SOURCE - 1Ø / <3Ø>	V/Ph/Hz		220 - 240 / 1 / 50 / <380 - 415 / 3 / 50>		
EER - 1Ø / <3Ø>	W/W		3.38	3.19 / <3.21>	
COP - 1Ø / <3Ø>	W/W		3.48	3.51 / <3.56>	
REFRIGERANT TYPE / CONTROL			R22		
REFRIGERANT CONTROL (EXPANSION DEVICE)			OUTDOOR CAP. TUBE + TXV		
INDOOR UNIT	CONTROL	AIR DISCHARGE		DUCTED	
		OPERATION		SLM WIRED HANDSET	
	AIR FLOW	SUPER HIGH	l/s / CFM	727 / 1540	
		HIGH	l/s / CFM	694 / 1470	
		MEDIUM	l/s / CFM	670 / 1420	
		LOW	l/s / CFM	637 / 1350	
	EXTERNAL STATIC PRESSURE (H/M/L)	Pa (in.wg.)	137 / 118 / 108 / 88 (0.6 / 0.5 / 0.4 / 0.4)		
	SOUND PRESSURE LEVEL (H/M/L)	dBA	55 / 51 / 48 / 45		
	UNIT DIMENSION	HEIGHT	mm/in	305 / 12.0	
		WIDTH	mm/in	1302 / 51.3	
		DEPTH	mm/in	638 / 25.1	
	PACKING DIMENSION	HEIGHT	mm/in	355 / 14.0	
		WIDTH	mm/in	1461 / 57.5	
		DEPTH	mm/in	727 / 28.6	
	WEIGHT	kg/lb	41 / 90		
CONDENSATE DRAIN SIZE	mm/in	19.1 / 3/4			
OUTDOOR UNIT	AIR FLOW	l/s / CFM	1605 / 3400	1605 / 3400	
	SOUND PRESSURE LEVEL	dBA	58	58	
	UNIT DIMENSION	HEIGHT	mm/in	850 / 33.5	
		WIDTH	mm/in	1030 / 40.6	
		DEPTH	mm/in	400 / 15.8	
	PACKING DIMENSION	HEIGHT	mm/in	1000 / 39.4	
		WIDTH	mm/in	1200 / 47.2	
		DEPTH	mm/in	560 / 22.1	
	UNIT WEIGHT	kg/lb	95 / 209	100 / 221	
	PIPE CONNECTION	SIZE	TYPE		FLARE VALVE
LIQUID			mm/in	9.5 / 3/8	
GAS			mm/in	19.1 / 3/4	
REFRIGERANT CHARGE	kg/lb	2.60 / 5.73	2.60 / 5.73		

1) ALL SPECIFICATIONS ARE SUBJECTED TO CHANGE BY THE MANUFACTURER WITHOUT PRIOR NOTICE.

2) ALL UNITS ARE BEING TESTED AND COMPLY TO ISO 5151.

3) NOMINAL COOLING AND HEATING CAPACITY ARE BASED ON THE CONDITIONS BELOW :

a) COOLING - 27°C DB / 19°C WB INDOOR AND 35°C DB / 24°C WB OUTDOOR

b) HEATING - 20°C DB INDOOR AND 7°C DB / 6°C WB OUTDOOR

4) EER/COP CALCULATION IS BASED ON EFFECTIVE POWER INPUT AS PER ISO 5151.

General Data - Heat pump (R22)

MODEL	INDOOR UNIT		MCC 040CR		
	OUTDOOR UNIT		MLC 035CR	MLC 040CR	
NOMINAL COOLING CAPACITY- 1Ø / <3Ø>	Btu/h		33500	40000 / <40000>	
	W		9820	11720 / <11720>	
NOMINAL HEATING CAPACITY- 1Ø / <3Ø>	Btu/h		35000	40000 / <40000>	
	W		10260	11720 / <11720>	
NOMINAL TOTAL INPUT POWER (COOLING) - 1Ø / <3Ø>	W		3265	3728 / <3698>	
NOMINAL TOTAL INPUT POWER (HEATING) - 1Ø / <3Ø>	W		3265	3238 / <3208>	
NOMINAL RUNNING CURRENT (COOLING) - 1Ø / <3Ø>	A		16.4	18.0 / <5.4>	
NOMINAL RUNNING CURRENT (HEATING) - 1Ø / <3Ø>	A		16.4	16.6 / <4.0>	
POWER SOURCE - 1Ø / <3Ø>	V/Ph/Hz		220 - 240 / 1 / 50 / <380 - 415 / 3 / 50>		
EER - 1Ø / <3Ø>	W/W		3.30	3.41 / <3.44>	
COP - 1Ø / <3Ø>	W/W		3.45	3.73 / <3.76>	
REFRIGERANT TYPE / CONTROL			R22		
REFRIGERANT CONTROL (EXPANSION DEVICE)			OUTDOOR CAP. TUBE + TXV		
INDOOR UNIT	CONTROL		DUCTED		
	AIR DISCHARGE OPERATION		SLM WIRED HANDSET		
	AIR FLOW	SUPER HIGH	l/s / CFM	519 / 1100	
		HIGH	l/s / CFM	500 / 1060	
		MEDIUM	l/s / CFM	467 / 990	
		LOW	l/s / CFM	425 / 900	
	EXTERNAL STATIC PRESSURE (H/M/L)		Pa (in.wg.)	206 / 176 / 127 / 93 (0.8 / 0.7 / 0.5 / 0.4)	
	SOUND PRESSURE LEVEL (H/M/L)		dBA	51 / 49 / 45 / 41	
	UNIT DIMENSION	HEIGHT	mm/in	378 / 14.9	
		WIDTH	mm/in	1045 / 41.1	
		DEPTH	mm/in	541 / 21.3	
	PACKING DIMENSION	HEIGHT	mm/in	415 / 16.3	
		WIDTH	mm/in	1245 / 49.0	
		DEPTH	mm/in	631 / 24.8	
	WEIGHT		kg/lb	42 / 93	
CONDENSATE DRAIN SIZE		mm/in	19.1 / 3/4		
AIR FLOW		l/s / CFM	1605 / 3400	1605 / 3400	
SOUND PRESSURE LEVEL		dBA	58	58	
UNIT DIMENSION	HEIGHT	mm/in	850 / 33.5		
	WIDTH	mm/in	1030 / 40.6		
	DEPTH	mm/in	400 / 15.8		
PACKING DIMENSION	HEIGHT	mm/in	1000 / 39.4		
	WIDTH	mm/in	1200 / 47.2		
	DEPTH	mm/in	560 / 22.1		
UNIT WEIGHT		kg/lb	95 / 209	100 / 221	
PIPE CONNECTION	TYPE		FLARE VALVE		
	SIZE	LIQUID	mm/in		
		GAS	mm/in		
REFRIGERANT CHARGE		kg/lb	2.60 / 5.73	2.60 / 5.73	

- 1) ALL SPECIFICATIONS ARE SUBJECTED TO CHANGE BY THE MANUFACTURER WITHOUT PRIOR NOTICE.
- 2) ALL UNITS ARE BEING TESTED AND COMPLY TO ISO 5151.
- 3) NOMINAL COOLING AND HEATING CAPACITY ARE BASED ON THE CONDITIONS BELOW :
 - a) COOLING - 27°C DB / 19°C WB INDOOR AND 35°C DB / 24°C WB OUTDOOR
 - b) HEATING - 20°C DB INDOOR AND 7°C DB / 6°C WB OUTDOOR
- 4) EER/COP CALCULATION IS BASED ON EFFECTIVE POWER INPUT AS PER ISO 5151.

General Data - Heat pump (R22)

MODEL	INDOOR UNIT		MCC 050CR	MCC 060CR	
	OUTDOOR UNIT		MLC 050CR	MLC 061CR	
NOMINAL COOLING CAPACITY	Btu/h		50000	56000	
	W		14650	16410	
NOMINAL HEATING CAPACITY	Btu/h		53000	56000	
	W		15530	16410	
NOMINAL TOTAL INPUT POWER (COOLING)	W		5047	6010	
NOMINAL TOTAL INPUT POWER (HEATING)	W		4447	4980	
NOMINAL RUNNING CURRENT (COOLING)	A		9.0	10.0	
NOMINAL RUNNING CURRENT (HEATING)	A		6.0	8.8	
POWER SOURCE	V/Ph/Hz		380 - 415 / 3 / 50	380 - 415 / 3 / 50	
EER	W/W		3.11	2.91	
COP	W/W		3.78	3.57	
REFRIGERANT TYPE			R22	R22	
REFRIGERANT CONTROL (EXPANSION DEVICE)			OUTDOOR CAP. TUBE + TXV	INDOOR & OUTDOOR CAP. TUBE	
INDOOR UNIT	CONTROL	AIR DISCHARGE		DUCTED	
		OPERATION		SLM WIRED HANDSET	
	AIR FLOW	SUPER HIGH	l/s / CFM	750 / 1590	779 / 1650
		HIGH	l/s / CFM	651 / 1380	722 / 1530
		MEDIUM	l/s / CFM	604 / 1280	675 / 1430
		LOW	l/s / CFM	571 / 1210	609 / 1290
	EXTERNAL STATIC PRESSURE (H/M/L)	Pa (in.wg.)	176 / 157 / 137 / 108 (0.7 / 0.6 / 0.6 / 0.4)	176 / 157 / 137 / 98 (0.7 / 0.6 / 0.6 / 0.4)	
	SOUND PRESSURE LEVEL (H/M/L)	dBA	53 / 52 / 50 / 47	55 / 53 / 50 / 47	
	UNIT DIMENSION	HEIGHT	mm/in	378 / 14.9	378 / 14.9
		WIDTH	mm/in	1299 / 51.1	1499 / 59.0
		DEPTH	mm/in	541 / 21.3	541 / 21.3
	PACKING DIMENSION	HEIGHT	mm/in	415 / 16.3	415 / 16.3
		WIDTH	mm/in	1497 / 59.0	1701 / 67.0
		DEPTH	mm/in	631 / 24.8	631 / 24.8
	WEIGHT	kg/lb	54 / 119	62 / 137	
CONDENSATE DRAIN SIZE	mm/in	19.1 / 3/4			
OUTDOOR UNIT	AIR FLOW	l/s / CFM	1605 / 3400	1793 / 3800	
	SOUND PRESSURE LEVEL	dBA	58	61	
	UNIT DIMENSION	HEIGHT	mm/in	850 / 33.5	850 / 33.5
		WIDTH	mm/in	1030 / 40.6	1030 / 40.6
		DEPTH	mm/in	400 / 15.8	460 / 18.1
	PACKING DIMENSION	HEIGHT	mm/in	1000 / 39.4	1016 / 40.0
		WIDTH	mm/in	1200 / 47.2	1178 / 46.4
		DEPTH	mm/in	560 / 22.1	602 / 23.7
	UNIT WEIGHT	kg/lb	105 / 231	108 / 238	
	PIPE CONNECTION	SIZE	TYPE		FLARE VALVE
LIQUID			mm/in	9.5 / 3/8	12.7 / 1/2
GAS			mm/in	19.1 / 3/4	19.1 / 3/4
REFRIGERANT CHARGE	kg/lb	2.75 / 5.73	5.00 / 11.02		

1) ALL SPECIFICATIONS ARE SUBJECTED TO CHANGE BY THE MANUFACTURER WITHOUT PRIOR NOTICE.

2) ALL UNITS ARE BEING TESTED AND COMPLY TO ISO 5151.

3) NOMINAL COOLING AND HEATING CAPACITY ARE BASED ON THE CONDITIONS BELOW :

a) COOLING - 27°C DB / 19°C WB INDOOR AND 35°C DB / 24°C WB OUTDOOR

b) HEATING - 20°C DB INDOOR AND 7°C DB / 6°C WB OUTDOOR

4) EER/COP CALCULATION IS BASED ON EFFECTIVE POWER INPUT AS PER ISO 5151.

General Data - Cooling Only (R410A)

MODEL	INDOOR UNIT		M5CC 010C	M5CC 015C	
	OUTDOOR UNIT		M5LC 010C	M5LC 015C	
NOMINAL CAPACITY	Btu/h		9500	12500	
	W		2780	3660	
NOMINAL TOTAL INPUT POWER	W		961	1297	
NOMINAL RUNNING CURRENT	A		4.0	5.7	
POWER SOURCE	V/Ph/Hz		220 - 240 / 1 / 50	220 / 1 / 50	
EER	W/W		2.96	2.91	
REFRIGERANT TYPE	R410A				
REFRIGERANT CONTROL (EXPANSION DEVICE)	OUTDOOR CAP. TUBE				
INDOOR UNIT	CONTROL	AIR DISCHARGE OPERATION		DUCTED	
				SLM WIRED HANDSET	
	AIR FLOW	HIGH	l/s / CFM	142 / 300	241 / 510
		MEDIUM	l/s / CFM	123 / 260	208 / 440
		LOW	l/s / CFM	104 / 220	170 / 360
	EXTERNAL STATIC PRESSURE (H/M/L)	Pa (in.wg.)	49 / 39 / 29 (0.2 / 0.2 / 0.1)		
	SOUND PRESSURE LEVEL (H/M/L)	dBA	33 / 30 / 26		
	UNIT DIMENSION	HEIGHT	mm/in	261 / 10.3	
		WIDTH	mm/in	765 / 30.1	
		DEPTH	mm/in	411 / 16.2	
	PACKING DIMENSION	HEIGHT	mm/in	376 / 14.8	
		WIDTH	mm/in	951 / 37.4	
		DEPTH	mm/in	541 / 21.3	
	WEIGHT	kg/lb	17 / 38		
	CONDENSATE DRAIN SIZE	mm/in	19.1 / 3/4		
OUTDOOR UNIT	AIR FLOW	l/s / CFM	396 / 840		
	SOUND PRESSURE LEVEL	dBA	46		
	UNIT DIMENSION	HEIGHT	mm/in	540 / 21.3	
		WIDTH	mm/in	700 / 27.6	
		DEPTH	mm/in	250 / 9.8	
	PACKING DIMENSION	HEIGHT	mm/in	620 / 24.4	
		WIDTH	mm/in	810 / 31.9	
		DEPTH	mm/in	330 / 13.0	
	UNIT WEIGHT	kg/lb	32 / 71		
	PIPE CONNECTION	TYPE		FLARE VALVE	
SIZE		LIQUID	mm/in	6.4 / 1/4	
		GAS	mm/in	9.5 / 3/8	
REFRIGERANT CHARGE	kg/lb	0.71 / 1.57			

1) ALL SPECIFICATIONS ARE SUBJECTED TO CHANGE BY THE MANUFACTURER WITHOUT PRIOR NOTICE.

2) ALL UNITS ARE BEING TESTED AND COMPLY TO ISO 5151.

3) NOMINAL COOLING AND HEATING CAPACITY ARE BASED ON THE CONDITIONS BELOW :
COOLING - 27°C DB / 19°C WB INDOOR AND 35°C DB / 24°C WB OUTDOOR

4) EER/COP CALCULATION IS BASED ON EFFECTIVE POWER INPUT AS PER ISO 5151.

General Data - Cooling Only (R410A)

MODEL	INDOOR UNIT		M5CC 020C	M5CC 025C	
	OUTDOOR UNIT		M5LC 020C	M5LC 025C	
NOMINAL CAPACITY - 1Ø / <3Ø>	Btu/h		18000 / <18000>	21000 / <22860>	
	W		5280 / <5280>	6160 / <6700>	
NOMINAL TOTAL INPUT POWER - 1Ø / <3Ø>	W		1757 / <1791>	2003 / <2274>	
NOMINAL RUNNING CURRENT - 1Ø / <3Ø>	A		7.6 / <3.4>	8.9 / <4.2>	
POWER SOURCE - 1Ø / <3Ø>	V/Ph/Hz		220 - 240 / 1 / 50 / <380 - 415 / 3 / 50>		
EER - 1Ø / <3Ø>	W/W		3.13 / <3.07>	3.15 / <3.02>	
REFRIGERANT TYPE			R410A		
REFRIGERANT CONTROL (EXPANSION DEVICE)			OUTDOOR CAP. TUBE		
INDOOR UNIT	CONTROL	AIR DISCHARGE		DUCTED	
		OPERATION		SLM WIRED HANDSET	
	AIR FLOW	HEIGHT	l/s / CFM	330 / 700	345 / 730
		MEDIUM	l/s / CFM	321 / 680	340 / 720
		LOW	l/s / CFM	293 / 620	274 / 580
	EXTERNAL STATIC PRESSURE (H/M/L)		Pa (in.wg.)	64 / 58 / 34 (0.3 / 0.2 / 0.1)	
	SOUND PRESSURE LEVEL (H/M/L)		dBA	38 / 36 / 34	
	UNIT DIMENSION	HEIGHT	mm/in	261 / 10.3	
		WIDTH	mm/in	1065 / 41.9	
		DEPTH	mm/in	411 / 16.2	
	PACKING DIMENSION	HEIGHT	mm/in	376 / 14.8	
		WIDTH	mm/in	1251 / 49.3	
		DEPTH	mm/in	541 / 21.3	
	WEIGHT		kg/lb	22 / 49	
CONDENSATE DRAIN SIZE		mm/in	19.1 / 3/4		
OUTDOOR UNIT	AIR FLOW		l/s / CFM	614 / 1300	
	SOUND PRESSURE LEVEL		dBA	52	
	UNIT DIMENSION	HEIGHT	mm/in	648 / 25.5	
		WIDTH	mm/in	855 / 33.7	
		DEPTH	mm/in	328 / 12.9	
	PACKING DIMENSION	HEIGHT	mm/in	710 / 28.0	
		WIDTH	mm/in	990 / 39.0	
		DEPTH	mm/in	415 / 16.3	
	UNIT WEIGHT		kg/lb	59 / 130	
	PIPE CONNECTION	TYPE		FLARE VALVE	
		SIZE	LIQUID	mm/in	6.4 / 1/4
GAS			mm/in	12.7 / 1/2	
REFRIGERANT CHARGE		kg/lb	1.38 / 3.04		
			1.60 / 3.53		

- 1) ALL SPECIFICATIONS ARE SUBJECTED TO CHANGE BY THE MANUFACTURER WITHOUT PRIOR NOTICE.
- 2) ALL UNITS ARE BEING TESTED AND COMPLY TO ISO 5151.
- 3) NOMINAL COOLING AND HEATING CAPACITY ARE BASED ON THE CONDITIONS BELOW :
COOLING - 27°C DB / 19°C WB INDOOR AND 35°C DB / 24°C WB OUTDOOR
- 4) EER/COP CALCULATION IS BASED ON EFFECTIVE POWER INPUT AS PER ISO 5151.

General Data - Cooling Only (R410A)

MODEL	INDOOR UNIT		M5CC 028C	
	OUTDOOR UNIT		M5LC 028C	
NOMINAL CAPACITY - 1Ø / <3Ø>	Btu/h		26000 / <27000>	
	W		7620 / <7910>	
NOMINAL TOTAL INPUT POWER - 1Ø / <3Ø>	W		2892 / <2876>	
NOMINAL RUNNING CURRENT -1Ø / <3Ø>	A		12.8 / <4.9>	
POWER SOURCE - 1Ø / <3Ø>	V/Ph/Hz		220 - 240 / 1 / 50 / <380 - 415 / 3 / 50>	
EER - 1Ø / <3Ø>	W/W		2.73 / <2.85>	
REFRIGERANT TYPE			R410A	
REFRIGERANT CONTROL (EXPANSION DEVICE)			OUTDOOR CAP. TUBE	
INDOOR UNIT	CONTROL	AIR DISCHARGE		DUCTED
		OPERATION		SLM WIRED HANDSET
	AIR FLOW	SUPER HIGH	l/s / CFM	401 / 850
		HIGH	l/s / CFM	382 / 810
		MEDIUM	l/s / CFM	363 / 770
		LOW	l/s / CFM	335 / 710
	EXTERNAL STATIC PRESSURE (H/M/L)		Pa (in.wg.)	98 / 78 / 68 / 59 (0.4 / 0.3 / 0.3 / 0.2)
	SOUND PRESSURE LEVEL (H/M/L)		dBA	44 / 41 / 38 / 34
	UNIT DIMENSION	HEIGHT	mm/in	285 / 11.2
		WIDTH	mm/in	1007 / 39.7
		DEPTH	mm/in	600 / 23.6
	PACKING DIMENSION	HEIGHT	mm/in	343 / 13.5
		WIDTH	mm/in	1138 / 44.8
		DEPTH	mm/in	690 / 27.2
	WEIGHT		kg/lb	38 / 84
CONDENSATE DRAIN SIZE		mm/in	19.1 / 3/4	
OUTDOOR UNIT	AIR FLOW		l/s / CFM	684 / 1450
	SOUND PRESSURE LEVEL		dBA	54
	UNIT DIMENSION	HEIGHT	mm/in	750 / 29.5
		WIDTH	mm/in	855 / 33.7
		DEPTH	mm/in	328 / 12.9
	PACKING DIMENSION	HEIGHT	mm/in	810 / 31.9
		WIDTH	mm/in	990 / 39.0
		DEPTH	mm/in	415 / 16.3
	UNIT WEIGHT		kg/lb	68 / 150
	PIPE CONNECTION	TYPE		FLARE VALVE
SIZE		LIQUID	mm/in	9.5 / 3/8
		GAS	mm/in	15.9 / 5/8
REFRIGERANT CHARGE		kg/lb	1.80 / 3.97	

1) ALL SPECIFICATIONS ARE SUBJECTED TO CHANGE BY THE MANUFACTURER WITHOUT PRIOR NOTICE.

2) ALL UNITS ARE BEING TESTED AND COMPLY TO ISO 5151.

3) NOMINAL COOLING AND HEATING CAPACITY ARE BASED ON THE CONDITIONS BELOW:
COOLING - 27°C DB / 19°C WB INDOOR AND 35°C DB / 24°C WB OUTDOOR

4) EER/COP CALCULATION IS BASED ON EFFECTIVE POWER INPUT AS PER ISO 5151.

General Data - Cooling Only (R410A)

MODEL	INDOOR UNIT		M5CC 038C		
	OUTDOOR UNIT		M5LC 035C	M5LC 040C	
NOMINAL COOLING CAPACITY - 1Ø / <3Ø>	Btu/h		32000 / <33000>	<39000>	
	W		9380 / <9670>	<11430>	
NOMINAL TOTAL INPUT POWER - 1Ø / <3Ø>	W		3287 / <3427>	<4173>	
NOMINAL RUNNING CURRENT - 1Ø / <3Ø>	A		15.2 / <5.9>	<7.4>	
POWER SOURCE - 1Ø / <3Ø>	V/Ph/Hz		220 - 240 / 1 / 50 / <380 - 415 / 3 / 50>		
EER - 1Ø / <3Ø>	W/W		3.07 / <3.03>	<2.88>	
REFRIGERANT TYPE	R410A				
REFRIGERANT CONTROL (EXPANSION DEVICE)	OUTDOOR CAP. TUBE				
INDOOR UNIT	CONTROL	AIR DISCHARGE		DUCTED	
		OPERATION		SLM WIRED HANDSET	
	AIR FLOW	SUPER HIGH	l/s / CFM	603 / 1280	
		HIGH	l/s / CFM	546 / 1160	
		MEDIUM	l/s / CFM	495 / 1050	
		LOW	l/s / CFM	433 / 920	
	EXTERNAL STATIC PRESSURE (H/M/L)	Pa (in. wg.)	118 / 96 / 78 / 61 (0.47 / 0.39 / 0.31 / 0.24)		
	SOUND PRESSURE LEVEL (H/M/L)	dBA	52 / 49 / 47 / 45		
	UNIT DIMENSION	HEIGHT	mm/in	305 / 12.0	
		WIDTH	mm/in	1302 / 51.3	
		DEPTH	mm/in	638 / 25.1	
	PACKING DIMENSION	HEIGHT	mm/in	355 / 14.0	
		WIDTH	mm/in	1461 / 57.5	
		DEPTH	mm/in	727 / 28.6	
	WEIGHT	kg/lb	41 / 90		
CONDENSATE DRAIN SIZE	mm/in	19.1 / 0.75			
OUTDOOR UNIT	AIR FLOW	l/s / CFM	1605 / 3400		
	SOUND PRESSURE LEVEL	dBA	58		
	UNIT DIMENSION	HEIGHT	mm/in	850 / 33.5	
		WIDTH	mm/in	1030 / 40.6	
		DEPTH	mm/in	400 / 15.8	
	PACKING DIMENSION	HEIGHT	mm/in	1000 / 39.4	
		WIDTH	mm/in	1200 / 47.2	
		DEPTH	mm/in	560 / 22.1	
	UNIT WEIGHT	kg/lb	95 / 209		
	PIPE CONNECTION	TYPE		FLARE VALVE	
		SIZE	LIQUID	mm/in	9.5 / 3/8
GAS			mm/in	15.9 / 5/8	
REFRIGERANT CHARGE	kg/lb	2.6 / 5.73	2.175 / 4.80		

1) ALL SPECIFICATIONS ARE SUBJECTED TO CHANGE BY THE MANUFACTURER WITHOUT PRIOR NOTICE.

2) ALL UNITS ARE BEING TESTED AND COMPLY TO ISO 5151.

3) NOMINAL COOLING AND HEATING CAPACITY ARE BASED ON THE CONDITIONS BELOW :

a) COOLING - 27°C DB / 19°C WB INDOOR AND 35°C DB / 24°C WB OUTDOOR

b) HEATING - 20°C DB INDOOR AND 7°C DB / 6°C WB OUTDOOR

4) EER/COP CALCULATION IS BASED ON EFFECTIVE POWER INPUT AS PER ISO 5151.

General Data - Cooling Only (R410A)

MODEL	INDOOR UNIT		M5CC 050C	M5CC 060C	
	OUTDOOR UNIT		M5LC 050C	M5LC 061C	
NOMINAL CAPACITY	Btu/h		48000	54500	
	W		14070	15970	
NOMINAL TOTAL INPUT POWER	W		5115	5758	
NOMINAL RUNNING CURRENT	A		8.9	9.7	
POWER SOURCE	V/Ph/Hz		380 - 415 / 3 / 50	380 - 415 / 3 / 50	
EER	W/W		2.94	2.98	
REFRIGERANT TYPE	R410A				
REFRIGERANT CONTROL (EXPANSION DEVICE)	OUTDOOR CAP. TUBE & TXV				
INDOOR UNIT	CONTROL	AIR DISCHARGE OPERATION		DUCTED	
				SLM WIRED HANDSET	
	AIR FLOW	SUPER HIGH	l/s / CFM	675 / 1430	812 / 1720
		HIGH	l/s / CFM	623 / 1320	732 / 1550
		MEDIUM	l/s / CFM	580 / 1230	632 / 1340
		LOW	l/s / CFM	533 / 1130	552 / 1170
	EXTERNAL STATIC PRESSURE (H/M/L)	Pa (in.wg.)	147 / 126 / 109 / 92 (0.6 / 0.5 / 0.4 / 0.4)	147 / 120 / 90 / 69 (0.6 / 0.5 / 0.4 / 0.3)	
	SOUND PRESSURE LEVEL (H/M/L)	dBA	54 / 53 / 52 / 51	54 / 52 / 49 / 46	
	UNIT DIMENSION	HEIGHT	mm/in	378 / 14.9	378 / 14.9
		WIDTH	mm/in	1299 / 51.1	1499 / 59.0
		DEPTH	mm/in	541 / 21.3	541 / 21.3
	PACKING DIMENSION	HEIGHT	mm/in	415 / 16.3	415 / 16.3
		WIDTH	mm/in	1497 / 59.0	1701 / 67.0
		DEPTH	mm/in	631 / 24.8	631 / 24.8
WEIGHT	kg/lb	54 / 119	62 / 137		
CONDENSATE DRAIN SIZE	mm/in	19.1 / 3/4			
OUTDOOR UNIT	AIR FLOW	l/s / CFM	2171 / 4600	2171 / 4600	
	SOUND PRESSURE LEVEL	dBA	68	65	
	UNIT DIMENSION	HEIGHT	mm/in	850 / 33.5	850 / 33.5
		WIDTH	mm/in	1030 / 40.6	1030 / 40.6
		DEPTH	mm/in	400 / 15.8	460 / 18.1
	PACKING DIMENSION	HEIGHT	mm/in	1000 / 39.4	1016 / 40.0
		WIDTH	mm/in	1200 / 47.2	1178 / 46.4
		DEPTH	mm/in	560 / 22.1	602 / 23.7
	UNIT WEIGHT	kg/lb	105 / 232	108 / 238	
	PIPE CONNECTION	TYPE		FLARE VALVE	
		SIZE	LIQUID	mm/in	9.5 / 3/8
GAS			mm/in	15.9 / 5/8	19.1 / 3/4
REFRIGERANT CHARGE	kg/lb	2.73 / 6.01	3.3 / 7.27		

1) ALL SPECIFICATIONS ARE SUBJECTED TO CHANGE BY THE MANUFACTURER WITHOUT PRIOR NOTICE.

2) ALL UNITS ARE BEING TESTED AND COMPLY TO ISO 5151.

3) NOMINAL COOLING AND HEATING CAPACITY ARE BASED ON THE CONDITIONS BELOW :

COOLING - 27°C DB / 19°C WB INDOOR AND 35°C DB / 24°C WB OUTDOOR

4) EER/COP CALCULATION IS BASED ON EFFECTIVE POWER INPUT AS PER ISO 5151.

General Data - Heat Pump (R410A)

MODEL	INDOOR UNIT		M5CC 010CR	M5CC 015CR	
	OUTDOOR UNIT		M5LC 010CR	M5LC 015CR	
NOMINAL COOLING CAPACITY	Btu/h		9500	12500	
	W		2780	3660	
NOMINAL HEATING CAPACITY	Btu/h		9500	12000	
	W		2780	3515	
NOMINAL TOTAL INPUT POWER (COOLING)	W		961	1297	
NOMINAL TOTAL INPUT POWER (HEATING)	W		813	1147	
NOMINAL RUNNING CURRENT (COOLING)	A		4.3	5.7	
NOMINAL RUNNING CURRENT (HEATING)	A		3.7	5.2	
POWER SOURCE	V/Ph/Hz		220 - 240 / 1 / 50	220 - 240 / 1 / 50	
EER	W/W		2.96	2.91	
COP	W/W		3.52	3.18	
REFRIGERANT TYPE			R410A		
REFRIGERANT CONTROL (EXPANSION DEVICE)			OUTDOOR CAP. TUBE		
INDOOR UNIT	CONTROL	AIR DISCHARGE		DUCTED	
		OPERATION		SLM WIRED HANDSET	
	AIR FLOW	HIGH	l/s / CFM	142 / 300	241 / 510
		MEDIUM	l/s / CFM	123 / 260	208 / 440
		LOW	l/s / CFM	104 / 220	170 / 360
	EXTERNAL STATIC PRESSURE (H/M/L)	Pa (in.wg.)	49 / 39 / 29 (0.2 / 0.2 / 0.1)		
	SOUND PRESSURE LEVEL (H/M/L)	dBA	33 / 30 / 26		
	UNIT DIMENSION	HEIGHT	mm/in	261 / 10.3	
		WIDTH	mm/in	765 / 30.1	
		DEPTH	mm/in	411 / 16.2	
	PACKING DIMENSION	HEIGHT	mm/in	376 / 14.8	
		WIDTH	mm/in	951 / 37.4	
		DEPTH	mm/in	541 / 21.3	
	WEIGHT	kg/lb	17 / 38		
CONDENSATE DRAIN SIZE	mm/in	19.1 / 3/4			
OUTDOOR UNIT	AIR FLOW	l/s / CFM	396 / 840		
	SOUND PRESSURE LEVEL	dBA	46		
	UNIT DIMENSION	HEIGHT	mm/in	540 / 21.3	
		WIDTH	mm/in	700 / 27.6	
		DEPTH	mm/in	250 / 9.8	
	PACKING DIMENSION	HEIGHT	mm/in	620 / 24.4	
		WIDTH	mm/in	810 / 31.9	
		DEPTH	mm/in	330 / 13.0	
	UNIT WEIGHT	kg/lb	32 / 71		
	PIPE CONNECTION	SIZE	TYPE		FLARE VALVE
LIQUID			mm/in	6.4 / 1/4	
GAS		mm/in	9.5 / 3/8		
REFRIGERANT CHARGE	kg/lb	0.71 / 1.57			
			0.94 / 2.07		

1) ALL SPECIFICATIONS ARE SUBJECTED TO CHANGE BY THE MANUFACTURER WITHOUT PRIOR NOTICE.

2) ALL UNITS ARE BEING TESTED AND COMPLY TO ISO 5151.

3) NOMINAL COOLING AND HEATING CAPACITY ARE BASED ON THE CONDITIONS BELOW :

a) COOLING - 27°C DB / 19°C WB INDOOR AND 35°C DB / 24°C WB OUTDOOR

b) HEATING - 20°C DB INDOOR AND 7°C DB / 6°C WB OUTDOOR

4) EER/COP CALCULATION IS BASED ON EFFECTIVE POWER INPUT AS PER ISO 5151.

General Data - Heat Pump (R410A)

MODEL	INDOOR UNIT		M5CC 020CR	M5CC 025CR	
	OUTDOOR UNIT		M5LC 020CR	M5LC 025CR	
NOMINAL COOLING CAPACITY - 1Ø / <3Ø>	Btu/h		18000 / <18000>	21000 / <22860>	
	W		5280 / <5280>	6160 / <6700>	
NOMINAL HEATING CAPACITY - 1Ø / <3Ø>	Btu/h		18500 / <18500>	22000 / <23200>	
	W		5420 / <5420>	6450 / <6800>	
NOMINAL TOTAL INPUT POWER (COOLING) - 1Ø / <3Ø>	W		1757 / <1791>	2003 / <2274>	
NOMINAL TOTAL INPUT POWER (HEATING) - 1Ø / <3Ø>	W		1597 / <1561>	1953 / <2167>	
NOMINAL RUNNING CURRENT (COOLING) - 1Ø / <3Ø>	A		7.6 / <3.4>	8.9 / <4.2>	
NOMINAL RUNNING CURRENT (HEATING) - 1Ø / <3Ø>	A		7.4 / <2.9>	8.8 / <4.0>	
POWER SOURCE - 1Ø / <3Ø>	V/Ph/Hz		220 - 240 / 1 / 50 / <380 - 415 / 3 / 50>		
EER - 1Ø / <3Ø>	W/W		3.13 / <3.07>	3.15 / <3.02>	
COP - 1Ø / <3Ø>	W/W		3.55 / <3.64>	3.39 / <3.22>	
REFRIGERANT TYPE			R410A		
REFRIGERANT CONTROL (EXPANSION DEVICE)			OUTDOOR CAP. TUBE		
INDOOR UNIT	CONTROL	AIR DISCHARGE OPERATION		DUCTED	
				SLM WIRED HANDSET	
	AIR FLOW	HIGH	l/s / CFM	330 / 700	345 / 730
		MEDIUM	l/s / CFM	321 / 680	340 / 720
		LOW	l/s / CFM	293 / 620	274 / 580
	EXTERNAL STATIC PRESSURE (H/M/L)		Pa (in.wg.)	64 / 58 / 34 (0.3 / 0.2 / 0.1)	
	SOUND PRESSURE LEVEL (H/M/L)		dBA	38 / 36 / 34	
	UNIT DIMENSION	HEIGHT	mm/in	261 / 10.3	
		WIDTH	mm/in	1065 / 41.9	
		DEPTH	mm/in	411 / 16.2	
	PACKING DIMENSION	HEIGHT	mm/in	376 / 14.8	
		WIDTH	mm/in	1251 / 49.3	
		DEPTH	mm/in	541 / 21.3	
	WEIGHT		kg/lb	22 / 49	
	CONDENSATE DRAIN SIZE		mm/in	19.1 / 3/4	
AIR FLOW		l/s / CFM	614 / 1300		
SOUND PRESSURE LEVEL		dBA	52		
UNIT DIMENSION	HEIGHT	mm/in	648 / 25.5		
	WIDTH	mm/in	855 / 33.7		
	DEPTH	mm/in	328 / 12.9		
PACKING DIMENSION	HEIGHT	mm/in	710 / 28.0		
	WIDTH	mm/in	990 / 39.0		
	DEPTH	mm/in	415 / 16.3		
UNIT WEIGHT		kg/lb	59 / 130		
PIPE CONNECTION	SIZE	TYPE		FLARE VALVE	
		LIQUID	mm/in	6.4 / 1/4	
		GAS	mm/in	12.7 / 1/2	
REFRIGERANT CHARGE		kg/lb	1.38 / 3.04		
			1.60 / 3.53		

- 1) ALL SPECIFICATIONS ARE SUBJECTED TO CHANGE BY THE MANUFACTURER WITHOUT PRIOR NOTICE.
- 2) ALL UNITS ARE BEING TESTED AND COMPLY TO ISO 5151.
- 3) NOMINAL COOLING AND HEATING CAPACITY ARE BASED ON THE CONDITIONS BELOW :
 - a) COOLING - 27°C DB / 19°C WB INDOOR AND 35°C DB / 24°C WB OUTDOOR
 - b) HEATING - 20°C DB INDOOR AND 7°C DB / 6°C WB OUTDOOR
- 4) EER/COP CALCULATION IS BASED ON EFFECTIVE POWER INPUT AS PER ISO 5151.

General Data - Heat pump (R410A)

MODEL	INDOOR UNIT		M5CC 028CR	
	OUTDOOR UNIT		M5LC 028CR	
NOMINAL COOLING CAPACITY - 1Ø / <3Ø>	Btu/h		26000 / <27000>	
	W		7620 / <7910>	
NOMINAL HEATING CAPACITY - 1Ø / <3Ø>	Btu/h		26000 / <28000>	
	W		7620 / <8210>	
NOMINAL TOTAL INPUT POWER (COOLING) - 1Ø / <3Ø>	W		2892 / <2876>	
NOMINAL TOTAL INPUT POWER (HEATING) - 1Ø / <3Ø>	W		2429 / <2528>	
NOMINAL RUNNING CURRENT (COOLING) - 1Ø / <3Ø>	A		12.8 / <4.9>	
NOMINAL RUNNING CURRENT (HEATING) - 1Ø / <3Ø>	A		11.2 / <4.5>	
POWER SOURCE - 1Ø / <3Ø>	V/Ph/Hz		220 - 240 / 1 / 50 / <380 - 415 / 3 / 50>	
EER - 1Ø / <3Ø>	W/W		2.73 / <2.85>	
COP - 1Ø / <3Ø>	W/W		3.27 / <3.38>	
REFRIGERANT TYPE			R410A	
REFRIGERANT CONTROL (EXPANSION DEVICE)			OUTDOOR CAP. TUBE	
INDOOR UNIT	CONTROL	AIR DISCHARGE		DUCTED
		OPERATION		SLM WIRED HANDSET
	AIR FLOW	SUPER HIGH	l/s / CFM	401 / 850
		HIGH	l/s / CFM	382 / 810
		MEDIUM	l/s / CFM	363 / 770
		LOW	l/s / CFM	335 / 710
	EXTERNAL STATIC PRESSURE (H/M/L)		Pa (in.wg.)	98 / 78 / 68 / 59 (0.39 / 0.31 / 0.28 / 0.24)
	SOUND PRESSURE LEVEL (H/M/L)		dBA	44 / 41 / 38 / 34
	UNIT DIMENSION	HEIGHT	mm/in	285 / 11.2
		WIDTH	mm/in	1007 / 39.7
		DEPTH	mm/in	600 / 23.6
	PACKING DIMENSION	HEIGHT	mm/in	343 / 13.5
		WIDTH	mm/in	1138 / 44.8
		DEPTH	mm/in	690 / 27.2
	WEIGHT		kg/lb	38 / 84
CONDENSATE DRAIN SIZE		mm/in	19.1 / 0.75	
OUTDOOR UNIT	AIR FLOW		l/s / CFM	684 / 1450
	SOUND PRESSURE LEVEL		dBA	54
	UNIT DIMENSION	HEIGHT	mm/in	750 / 29.5
		WIDTH	mm/in	855 / 33.7
		DEPTH	mm/in	328 / 12.9
	PACKING DIMENSION	HEIGHT	mm/in	810 / 31.9
		WIDTH	mm/in	990 / 39.0
		DEPTH	mm/in	415 / 16.3
	UNIT WEIGHT		kg/lb	68 / 150
	PIPE CONNECTION	TYPE		FLARE VALVE
SIZE		LIQUID	mm/in	9.5 / 3/8
		GAS	mm/in	15.9 / 5/8
REFRIGERANT CHARGE		kg/lb	1.80 / 3.97	

- 1) ALL SPECIFICATIONS ARE SUBJECTED TO CHANGE BY THE MANUFACTURER WITHOUT PRIOR NOTICE.
- 2) ALL UNITS ARE BEING TESTED AND COMPLY TO ISO 5151.
- 3) NOMINAL COOLING AND HEATING CAPACITY ARE BASED ON THE CONDITIONS BELOW :
 - a) COOLING - 27°C DB / 19°C WB INDOOR AND 35°C DB / 24°C WB OUTDOOR
 - b) HEATING - 20°C DB INDOOR AND 7°C DB / 6°C WB OUTDOOR
- 4) EER/COP CALCULATION IS BASED ON EFFECTIVE POWER INPUT AS PER ISO 5151.

General Data - Heat pump (R410A)

MODEL	INDOOR UNIT		M5CC 038CR		
	OUTDOOR UNIT		M5LC 035CR	M5LC 040CR	
NOMINAL COOLING CAPACITY - 1Ø / <3Ø>	Btu/h		32000 / <33000>	<39000>	
	W		9380 / <9670>	<11430>	
NOMINAL HEATING CAPACITY - 1Ø / <3Ø>	Btu/h		34000 / <36000>	<42000>	
	W		9960 / <10550>	<12310>	
NOMINAL TOTAL INPUT POWER (COOLING) - 1Ø / <3Ø>	W		3287 / <3427>	<4173>	
NOMINAL TOTAL INPUT POWER (HEATING) - 1Ø / <3Ø>	W		2987 / <3137>	<4203>	
NOMINAL RUNNING CURRENT (COOLING) - 1Ø / <3Ø>	A		15.2 / <5.9>	<7.4>	
NOMINAL RUNNING CURRENT (HEATING) - 1Ø / <3Ø>	A		14.0 / <5.5>	<7.0>	
POWER SOURCE - 1Ø / <3Ø>	V/Ph/Hz		220 - 240 / 1 / 50 / <380 - 415 / 3 / 50>		
EER - 1Ø / <3Ø>	W/W		3.07 / <3.03>	<2.88>	
COP - 1Ø / <3Ø>	W/W		3.62 / <3.64>	<3.08>	
REFRIGERANT TYPE			R410A		
REFRIGERANT CONTROL (EXPANSION DEVICE)			OUTDOOR CAP. TUBE		
INDOOR UNIT	CONTROL	AIR DISCHARGE		DUCTED	
		OPERATION		SLM WIRED HANDSET	
	AIR FLOW	SUPER HIGH	l/s / CFM	603 / 1280	
		HIGH	l/s / CFM	546 / 1160	
		MEDIUM	l/s / CFM	495 / 1050	
		LOW	l/s / CFM	433 / 920	
	EXTERNAL STATIC PRESSURE (H/M/L)	Pa (in. wg.)	118 / 96 / 78 / 61		
	SOUND PRESSURE LEVEL (H/M/L)	dBA	52 / 49 / 47 / 45		
	UNIT DIMENSION	HEIGHT	mm/in	305 / 12.0	
		WIDTH	mm/in	1302 / 51.3	
		DEPTH	mm/in	638 / 25.1	
	PACKING DIMENSION	HEIGHT	mm/in	355 / 14.0	
		WIDTH	mm/in	1461 / 57.5	
		DEPTH	mm/in	727 / 28.6	
	WEIGHT	kg/lb	41 / 90		
CONDENSATE DRAIN SIZE	mm/in	19.1 / 0.75			
OUTDOOR UNIT	AIR FLOW	l/s / CFM	1605 / 3400		
	SOUND PRESSURE LEVEL	dBA	58		
	UNIT DIMENSION	HEIGHT	mm/in	850 / 33.5	
		WIDTH	mm/in	1030 / 40.6	
		DEPTH	mm/in	400 / 15.8	
	PACKING DIMENSION	HEIGHT	mm/in	1000 / 39.4	
		WIDTH	mm/in	1200 / 47.2	
		DEPTH	mm/in	560 / 22.1	
	UNIT WEIGHT	kg/lb	95 / 209		
	PIPE CONNECTION	SIZE	TYPE		FLARE VALVE
LIQUID			mm/in	9.5 / 3/8	
GAS			mm/in	15.9 / 5/8	
REFRIGERANT CHARGE	kg/lb	2.6 / 5.73	2.175 / 4.80		

1) ALL SPECIFICATIONS ARE SUBJECTED TO CHANGE BY THE MANUFACTURER WITHOUT PRIOR NOTICE.

2) ALL UNITS ARE BEING TESTED AND COMPLY TO ISO 5151.

3) NOMINAL COOLING AND HEATING CAPACITY ARE BASED ON THE CONDITIONS BELOW :

a) COOLING - 27°C DB / 19°C WB INDOOR AND 35°C DB / 24°C WB OUTDOOR

b) HEATING - 20°C DB INDOOR AND 7°C DB / 6°C WB OUTDOOR

4) EER/COP CALCULATION IS BASED ON EFFECTIVE POWER INPUT AS PER ISO 5151.

General Data - Heat pump (R410A)

MODEL	INDOOR UNIT		M5CC 050CR	M5CC 060CR	
	OUTDOOR UNIT		M5LC 050CR	M5LC 061CR	
NOMINAL COOLING CAPACITY	Btu/h		48000	54500	
	W		14070	15970	
NOMINAL HEATING CAPACITY	Btu/h		49000	57000	
	W		14360	16710	
NOMINAL TOTAL INPUT POWER (COOLING)	W		5115	5765	
NOMINAL TOTAL INPUT POWER (HEATING)	W		4535	5685	
NOMINAL RUNNING CURRENT (COOLING)	A		8.9	9.7	
NOMINAL RUNNING CURRENT (HEATING)	A		8.2	9.7	
POWER SOURCE	V/Ph/Hz		380 - 415 / 3 / 50	380 - 415 / 3 / 50	
EER	W/W		2.94	2.98	
COP	W/W		3.42	3.16	
REFRIGERANT TYPE			R410A		
REFRIGERANT CONTROL (EXPANSION DEVICE)			OUTDOOR CAP. TUBE & TXV		
INDOOR UNIT	CONTROL	AIR DISCHARGE OPERATION		DUCTED	
				SLM WIRED HANDSET	
	AIR FLOW	SUPER HIGH	l/s / CFM	675 / 1430	812 / 1720
		HIGH	l/s / CFM	623 / 1320	732 / 1550
		MEDIUM	l/s / CFM	580 / 1230	632 / 1340
		LOW	l/s / CFM	533 / 1130	552 / 1170
	EXTERNAL STATIC PRESSURE (H/M/L)		Pa (in.wg.)	147 / 126 / 109 / 92 (0.6 / 0.5 / 0.4 / 0.4)	147 / 120 / 90 / 69 (0.6 / 0.5 / 0.4 / 0.3)
	SOUND PRESSURE LEVEL (H/M/L)		dB(A)	54 / 53 / 52 / 51	54 / 52 / 50 / 46
	UNIT DIMENSION	HEIGHT	mm/in	378 / 14.9	378 / 14.9
		WIDTH	mm/in	1299 / 51.1	1499 / 59.0
		DEPTH	mm/in	541 / 21.3	541 / 21.3
	PACKING DIMENSION	HEIGHT	mm/in	415 / 16.3	415 / 16.3
		WIDTH	mm/in	1497 / 59.0	1701 / 67.0
		DEPTH	mm/in	631 / 24.8	631 / 24.8
WEIGHT		kg/lb	54 / 119	62 / 137	
CONDENSATE DRAIN SIZE		mm/in	19.1 / 3/4		
OUTDOOR UNIT	AIR FLOW		l/s / CFM	2171 / 4600	2171 / 4600
	SOUND PRESSURE LEVEL		dB(A)	68	65
	UNIT DIMENSION	HEIGHT	mm/in	850 / 33.5	850 / 33.5
		WIDTH	mm/in	1030 / 40.6	1030 / 40.6
		DEPTH	mm/in	400 / 15.8	460 / 18.1
	PACKING DIMENSION	HEIGHT	mm/in	1000 / 39.4	1016 / 40.0
		WIDTH	mm/in	1200 / 47.2	1178 / 46.4
		DEPTH	mm/in	560 / 22.1	602 / 23.7
	UNIT WEIGHT		kg/lb	105 / 232	108 / 238
	PIPE CONNECTION	TYPE		FLARE VALVE	
SIZE		LIQUID	mm/in	9.5 / 3/8	9.5 / 3/8
		GAS	mm/in	15.9 / 5/8	19.1 / 3/4
REFRIGERANT CHARGE		kg/lb	2.73 / 6.01	3.3 / 7.27	

- 1) ALL SPECIFICATIONS ARE SUBJECTED TO CHANGE BY THE MANUFACTURER WITHOUT PRIOR NOTICE.
- 2) ALL UNITS ARE BEING TESTED AND COMPLY TO ISO 5151.
- 3) NOMINAL COOLING AND HEATING CAPACITY ARE BASED ON THE CONDITIONS BELOW :
 - a) COOLING - 27°C DB / 19°C WB INDOOR AND 35°C DB / 24°C WB OUTDOOR
 - b) HEATING - 20°C DB INDOOR AND 7°C DB / 6°C WB OUTDOOR
- 4) EER/COP CALCULATION IS BASED ON EFFECTIVE POWER INPUT AS PER ISO 5151.

General Data - Cooling Only (R22)(Low Static)

MODEL	INDOOR UNIT		MCC 010C	MCC 015C	
	OUTDOOR UNIT		MLC 010C	MLC 015C	
NOMINAL CAPACITY	Btu/h		9500	12300	
	W		2780	3600	
NOMINAL TOTAL INPUT POWER	W		900	1267	
NOMINAL RUNNING CURRENT	A		4.0	5.7	
POWER SOURCE	V/Ph/Hz		220 - 240 / 1 / 50	220 - 240 / 1 / 50	
EER	W/W		3.17	2.93	
REFRIGERANT TYPE			R22		
REFRIGERANT CONTROL (EXPANSION DEVICE)			OUTDOOR CAP. TUBE		
INDOOR UNIT	CONTROL	AIR DISCHARGE		DUCTED	
		OPERATION		SLM WIRED HANDSET	
	AIR FLOW	HEIGHT	l/s / CFM	127 / 300	255 / 540
		MEDIUM	l/s / CFM	118 / 250	222 / 470
		LOW	l/s / CFM	99 / 210	165 / 350
	EXTERNAL STATIC PRESSURE (H/M/L)		Pa (in.wg.)	20 / 10 / 5 (0.08 / 0.04 / 0.02)	20 / 10 / 5 (0.08 / 0.04 / 0.02)
	SOUND PRESSURE LEVEL (H/M/L)		dBA	33 / 30 / 26	37 / 34 / 29
	UNIT DIMENSION	HEIGHT	mm/in	261 / 10.3	261 / 10.3
		WIDTH	mm/in	765 / 30.1	905 / 35.6
		DEPTH	mm/in	411 / 16.2	411 / 16.2
	PACKING DIMENSION	HEIGHT	mm/in	376 / 14.8	376 / 14.8
		WIDTH	mm/in	951 / 37.4	1091 / 43.0
		DEPTH	mm/in	541 / 21.3	541 / 21.3
	WEIGHT		kg/lb	17 / 38	21 / 46
	CONDENSATE DRAIN SIZE		mm/in	19.1 / 3/4	
AIR FLOW		l/s / CFM	396 / 840	453 / 960	
SOUND PRESSURE LEVEL		dBA	46	49	
UNIT DIMENSION	HEIGHT	mm/in	540 / 21.3		
	WIDTH	mm/in	700 / 27.6		
	DEPTH	mm/in	250 / 9.8		
PACKING DIMENSION	HEIGHT	mm/in	620 / 24.4		
	WIDTH	mm/in	810 / 31.9		
	DEPTH	mm/in	330 / 13.0		
UNIT WEIGHT		kg/lb	32 / 71		
PIPE CONNECTION	TYPE		FLARE VALVE		
	SIZE	LIQUID	mm/in	6.4 / 1/4	
		GAS	mm/in	9.5 / 3/8	12.7 / 1/2
REFRIGERANT CHARGE		kg/lb	0.63 / 1.39	0.60 / 1.32	

1) ALL SPECIFICATIONS ARE SUBJECTED TO CHANGE BY THE MANUFACTURER WITHOUT PRIOR NOTICE.

2) ALL UNITS ARE BEING TESTED AND COMPLY TO ISO 5151.

3) NOMINAL COOLING AND HEATING CAPACITY ARE BASED ON THE CONDITIONS BELOW :

COOLING - 27°C DB / 19°C WB INDOOR AND 35°C DB / 24°C WB OUTDOOR

4) EER/COP CALCULATION IS BASED ON EFFECTIVE POWER INPUT AS PER ISO 5151.

General Data - Cooling Only (R22)(Low Static)

MODEL	INDOOR UNIT		MCC 020C	
	OUTDOOR UNIT		MLC 018C	MLC 020C
NOMINAL CAPACITY	Btu/h		18000	19000
	W		5280	5570
NOMINAL TOTAL INPUT POWER	W		1910	1895
NOMINAL RUNNING CURRENT	A		8.5	8.3
POWER SOURCE	V/Ph/Hz		220 - 240 / 1 / 50	220 - 240 / 1 / 50
EER	W/W		2.87	3.05
REFRIGERANT TYPE	R22			
REFRIGERANT CONTROL (EXPANSION DEVICE)	OUTDOOR CAP. TUBE			
INDOOR UNIT	CONTROL	AIR DISCHARGE		DUCTED
		OPERATION		SLM WIRED HANDSET
	AIR FLOW	HIGH	l/s / CFM	307 / 650
		MEDIUM	l/s / CFM	303 / 640
		LOW	l/s / CFM	269 / 570
	EXTERNAL STATIC PRESSURE (H/M/L)	Pa (in.wg.)		29 / 20 / 10 (0.12 / 0.08 / 0.04)
	SOUND PRESSURE LEVEL (H/M/L)	dBA		38 / 36 / 34
	UNIT DIMENSION	HEIGHT	mm/in	261 / 10.3
		WIDTH	mm/in	1065 / 41.9
		DEPTH	mm/in	411 / 16.2
	PACKING DIMENSION	HEIGHT	mm/in	376 / 14.8
		WIDTH	mm/in	1251 / 49.3
		DEPTH	mm/in	541 / 21.3
	WEIGHT	kg/lb		22 / 49
CONDENSATE DRAIN SIZE	mm/in		19.1 / 3/4	
OUTDOOR UNIT	AIR FLOW	l/s / CFM		614 / 1300
	SOUND PRESSURE LEVEL	dBA		51
	UNIT DIMENSION	HEIGHT	mm/in	648 / 25.5
		WIDTH	mm/in	855 / 33.7
		DEPTH	mm/in	328 / 12.9
	PACKING DIMENSION	HEIGHT	mm/in	710 / 28.0
		WIDTH	mm/in	990 / 39.0
		DEPTH	mm/in	415 / 16.3
	UNIT WEIGHT	kg/lb		58 / 128 59 / 130
	PIPE CONNECTION	TYPE		FLARE VALVE
		SIZE	LIQUID	mm/in
GAS			mm/in	15.9 / 5/8
REFRIGERANT CHARGE	kg/lb		1.60 / 3.53 1.35 / 2.98	

1) ALL SPECIFICATIONS ARE SUBJECTED TO CHANGE BY THE MANUFACTURER WITHOUT PRIOR NOTICE.

2) ALL UNITS ARE BEING TESTED AND COMPLY TO ISO 5151.

3) NOMINAL COOLING AND HEATING CAPACITY ARE BASED ON THE CONDITIONS BELOW :
COOLING - 27°C DB / 19°C WB INDOOR AND 35°C DB / 24°C WB OUTDOOR

4) EER/COP CALCULATION IS BASED ON EFFECTIVE POWER INPUT AS PER ISO 5151.

General Data - Cooling Only (R22)(Low Static)

MODEL	INDOOR UNIT		MCC 025C	
	OUTDOOR UNIT		MLC 025C	
NOMINAL CAPACITY	Btu/h		23500	
	W		6890	
NOMINAL TOTAL INPUT POWER	W		2616	
NOMINAL RUNNING CURRENT	A		11.7	
POWER SOURCE	V/Ph/Hz		220 - 240 / 1 / 50	
EER	W/W		2.70	
REFRIGERANT TYPE			R22	
REFRIGERANT CONTROL (EXPANSION DEVICE)			OUTDOOR CAP. TUBE	
INDOOR UNIT	CONTROL	AIR DISCHARGE		DUCTED
		OPERATION		SLM WIRED HANDSET
	AIR FLOW	HIGH	l/s / CFM	363 / 770
		MEDIUM	l/s / CFM	340 / 720
		LOW	l/s / CFM	274 / 580
	EXTERNAL STATIC PRESSURE (H/M/L)		Pa (in.wg.)	25 / 15 / 5 (0.10 / 0.06 / 0.02)
	SOUND PRESSURE LEVEL (H/M/L)		dBA	40 / 39 / 36
	UNIT DIMENSION	HEIGHT	mm/in	261 / 10.3
		WIDTH	mm/in	1200 / 47.2
		DEPTH	mm/in	411 / 16.2
	PACKING DIMENSION	HEIGHT	mm/in	376 / 14.8
		WIDTH	mm/in	1386 / 54.6
		DEPTH	mm/in	541 / 21.3
	WEIGHT		kg/lb	25 / 55
	CONDENSATE DRAIN SIZE		mm/in	19.1 / 3/4
OUTDOOR UNIT	AIR FLOW		l/s / CFM	755 / 1600
	SOUND PRESSURE LEVEL		dBA	53
	UNIT DIMENSION	HEIGHT	mm/in	750 / 29.5
		WIDTH	mm/in	855 / 33.7
		DEPTH	mm/in	328 / 12.9
	PACKING DIMENSION	HEIGHT	mm/in	810 / 31.9
		WIDTH	mm/in	990 / 39.0
		DEPTH	mm/in	415 / 16.3
	UNIT WEIGHT		kg/lb	62 / 137
	PIPE CONNECTION	TYPE		FLARE VALVE
SIZE		LIQUID	mm/in	9.5 / 3/8
		GAS	mm/in	15.9 / 5/8
REFRIGERANT CHARGE		kg/lb	1.50 / 3.31	

1) ALL SPECIFICATIONS ARE SUBJECTED TO CHANGE BY THE MANUFACTURER WITHOUT PRIOR NOTICE.

2) ALL UNITS ARE BEING TESTED AND COMPLY TO ISO 5151.

3) NOMINAL COOLING AND HEATING CAPACITY ARE BASED ON THE CONDITIONS BELOW :
COOLING - 27°C DB / 19°C WB INDOOR AND 35°C DB / 24°C WB OUTDOOR

4) EER/COP CALCULATION IS BASED ON EFFECTIVE POWER INPUT AS PER ISO 5151.

General Data - Cooling Only (R22)(Low Static)

MODEL	INDOOR UNIT		MCC 030C		
	OUTDOOR UNIT		MLC 028C	MLC 030C	
NOMINAL CAPACITY - 1Ø / <3Ø>	Btu/h		28000	29000 / <29000>	
	W		8210	8490 / <8490>	
NOMINAL TOTAL INPUT POWER - 1Ø / <3Ø>	W		3153	2690 / <2760>	
NOMINAL RUNNING CURRENT - 1Ø / <3Ø>	A		15.50	13.1 / <5.49>	
POWER SOURCE - 1Ø / <3Ø>	V/Ph/Hz		220 - 240 / 1 / 50 / <380 - 415 / 3 / 50>		
EER - 1Ø / <3Ø>	W/W		2.79	3.43 / <3.34>	
REFRIGERANT TYPE		R22			
REFRIGERANT CONTROL (EXPANSION DEVICE)		INDOOR CAP. TUBE			
INDOOR UNIT	CONTROL	AIR DISCHARGE		DUCTED	
		OPERATION		SLM WIRED HANDSET	
	AIR FLOW	SUPER HIGH	l/s / CFM	444 / 940	
		HIGH	l/s / CFM	415 / 880	
		MEDIUM	l/s / CFM	373 / 790	
		LOW	l/s / CFM	349 / 740	
	EXTERNAL STATIC PRESSURE (SH/H/M/L)		Pa (in.wg.)	49 / 39 / 29 / 20 (0.20 / 0.16 / 0.12 / 0.08)	
	SOUND PRESSURE LEVEL (SH/H/M/L)		dBA	49 / 46 / 42 / 38	
	UNIT DIMENSION	HEIGHT	mm/in	378 / 14.9	
		WIDTH	mm/in	929 / 36.6	
		DEPTH	mm/in	541 / 21.3	
	PACKING DIMENSION	HEIGHT	mm/in	415 / 16.3	
		WIDTH	mm/in	1126 / 44.3	
		DEPTH	mm/in	631 / 24.8	
	WEIGHT		kg/lb	39 / 86	
CONDENSATE DRAIN SIZE		mm/in	19.1 / 3/4		
OUTDOOR UNIT	AIR FLOW		l/s / CFM	741 / 1570	1605 / 3400
	SOUND PRESSURE LEVEL		dBA	54	58
	UNIT DIMENSION	HEIGHT	mm/in	750 / 29.5	850 / 33.5
		WIDTH	mm/in	855 / 33.7	1030 / 40.6
		DEPTH	mm/in	328 / 12.9	400 / 15.8
	PACKING DIMENSION	HEIGHT	mm/in	810 / 31.9	1000 / 39.4
		WIDTH	mm/in	990 / 39.0	1200 / 47.2
		DEPTH	mm/in	415 / 16.3	560 / 22.1
	UNIT WEIGHT		kg/lb	68 / 150	95 / 209
	PIPE CONNECTION	TYPE		FLARE VALVE	
		SIZE	LIQUID	mm/in	9.5 / 3/8
GAS			mm/in	15.9 / 5/8	
REFRIGERANT CHARGE		kg/lb	2.40 / 5.30	1.70 / 3.75	

1) ALL SPECIFICATIONS ARE SUBJECTED TO CHANGE BY THE MANUFACTURER WITHOUT PRIOR NOTICE.

2) ALL UNITS ARE BEING TESTED AND COMPLY TO ISO 5151.

3) NOMINAL COOLING AND HEATING CAPACITY ARE BASED ON THE CONDITIONS BELOW :
COOLING - 27°C DB / 19°C WB INDOOR AND 35°C DB / 24°C WB OUTDOOR

4) EER/COP CALCULATION IS BASED ON EFFECTIVE POWER INPUT AS PER ISO 5151.

General Data - Cooling Only (R22)(Low Static)

MODEL	INDOOR UNIT		MCC 040C		
	OUTDOOR UNIT		MLC 035C	MLC 040C	
NOMINAL CAPACITY - 1Ø / <3Ø>	Btu/h		33500	38500 / <38500>	
	W		9810	11280 / <11280>	
NOMINAL TOTAL INPUT POWER - 1Ø / <3Ø>	W		3290	3420 / <3390>	
NOMINAL RUNNING CURRENT - 1Ø / <3Ø>	A		16.40	18.50 / <5.90>	
POWER SOURCE - 1Ø / <3Ø>	V/Ph/Hz		220 - 240 / 1 / 50 / <380 - 415 / 3 / 50>		
EER - 1Ø / <3Ø>	W/W		3.27	3.61 / <3.64>	
REFRIGERANT TYPE			R22		
REFRIGERANT CONTROL (EXPANSION DEVICE)			INDOOR CAP. TUBE		
INDOOR UNIT	CONTROL	AIR DISCHARGE		DUCTED	
		OPERATION		SLM WIRED HANDSET	
	AIR FLOW	SUPER HIGH	l/s / CFM	562 / 1190	
		HIGH	l/s / CFM	500 / 1060	
		MEDIUM	l/s / CFM	472 / 1000	
		LOW	l/s / CFM	458 / 970	
	EXTERNAL STATIC PRESSURE (SH/H/M/L)		Pa (in.wg.)	49 / 39 / 29 / 20 (0.20 / 0.16 / 0.12 / 0.08)	
	SOUND PRESSURE LEVEL (SH/H/M/L)		dBA	51 / 49 / 45 / 41	
	UNIT DIMENSION	HEIGHT	mm/in	378 / 14.9	
		WIDTH	mm/in	1045 / 41.1	
		DEPTH	mm/in	541 / 21.3	
	PACKING DIMENSION	HEIGHT	mm/in	415 / 16.3	
		WIDTH	mm/in	1245 / 49.0	
		DEPTH	mm/in	631 / 24.8	
	WEIGHT		kg/lb	42 / 93	
CONDENSATE DRAIN SIZE		mm/in	19.1 / 3/4		
OUTDOOR UNIT	AIR FLOW		l/s / CFM	1605 / 3400	1605 / 3400
	SOUND PRESSURE LEVEL		dBA	58	58
	UNIT DIMENSION	HEIGHT	mm/in	850 / 33.5	
		WIDTH	mm/in	1030 / 40.6	
		DEPTH	mm/in	400 / 15.8	
	PACKING DIMENSION	HEIGHT	mm/in	1000 / 39.4	
		WIDTH	mm/in	1200 / 47.2	
		DEPTH	mm/in	560 / 22.1	
	UNIT WEIGHT		kg/lb	95 / 209	100 / 221
	PIPE CONNECTION	TYPE		FLARE VALVE	
SIZE		LIQUID	mm/in	9.5 / 3/8	
		GAS	mm/in	19.1 / 3/4	
REFRIGERANT CHARGE			kg/lb	1.90 / 4.19	2.40 / 5.29

1) ALL SPECIFICATIONS ARE SUBJECTED TO CHANGE BY THE MANUFACTURER WITHOUT PRIOR NOTICE.

2) ALL UNITS ARE BEING TESTED AND COMPLY TO ISO 5151.

3) NOMINAL COOLING AND HEATING CAPACITY ARE BASED ON THE CONDITIONS BELOW :

COOLING - 27°C DB / 19°C WB INDOOR AND 35°C DB / 24°C WB OUTDOOR

4) EER/COP CALCULATION IS BASED ON EFFECTIVE POWER INPUT AS PER ISO 5151.

General Data - Cooling Only (R22)(Low Static)

MODEL	INDOOR UNIT		MCC 050C	MCC 060C		
	OUTDOOR UNIT		MLC 050C	MLC 061C		
NOMINAL CAPACITY	Btu/h		47000	56000		
	W		13770	16410		
NOMINAL TOTAL INPUT POWER	W		4810	6000		
NOMINAL RUNNING CURRENT	A		8.6	10.0		
POWER SOURCE	V/Ph/Hz		380 - 415 / 3 / 50	380 - 415 / 3 / 50		
EER	W/W		3.08	2.92		
REFRIGERANT TYPE	R22					
REFRIGERANT CONTROL (EXPANSION DEVICE)	INDOOR CAP. TUBE					
INDOOR UNIT	CONTROL	AIR DISCHARGE		DUCTED		
		OPERATION		SLM WIRED HANDSET		
	AIR FLOW	SUPER HIGH	l/s / CFM	713 / 1510	802 / 1700	
		HIGH	l/s / CFM	628 / 1330	765 / 1620	
		MEDIUM	l/s / CFM	618 / 1310	717 / 1520	
		LOW	l/s / CFM	599 / 1270	693 / 1470	
	EXTERNAL STATIC PRESSURE (SH/H/M/L)	Pa (in.wg.)	78 / 59 / 39 / 20 (0.31 / 0.24 / 0.16 / 0.08)			
	SOUND PRESSURE LEVEL (SH/H/M/L)	dBA	53 / 52 / 50 / 47			
	UNIT DIMENSION	HEIGHT	mm/in	378 / 14.9	378 / 14.9	
		WIDTH	mm/in	1299 / 51.1	1499 / 59.0	
		DEPTH	mm/in	541 / 21.3	541 / 21.3	
	PACKING DIMENSION	HEIGHT	mm/in	415 / 16.3	415 / 16.3	
		WIDTH	mm/in	1497 / 59.0	1701 / 67.0	
		DEPTH	mm/in	631 / 24.8	631 / 24.8	
	WEIGHT	kg/lb		54 / 119	62 / 137	
CONDENSATE DRAIN SIZE	mm/in		19.1 / 3/4			
OUTDOOR UNIT	AIR FLOW	l/s / CFM		1605 / 3400	1793 / 3800	
	SOUND PRESSURE LEVEL	dBA		58	61	
	UNIT DIMENSION	HEIGHT	mm/in	850 / 33.5	850 / 33.5	
		WIDTH	mm/in	1030 / 40.6	1030 / 40.6	
		DEPTH	mm/in	400 / 15.8	460 / 18.1	
	PACKING DIMENSION	HEIGHT	mm/in	1000 / 39.4	1016 / 40.0	
		WIDTH	mm/in	1200 / 47.2	1178 / 46.4	
		DEPTH	mm/in	560 / 22.1	602 / 23.7	
	UNIT WEIGHT	kg/lb		105 / 232	108 / 238	
	PIPE CONNECTION	TYPE		FLARE VALVE		
		SIZE	LIQUID	mm/in	9.5 / 3/8	12.7 / 1/2
			GAS	mm/in	19.1 / 3/4	19.1 / 3/4
REFRIGERANT CHARGE	kg/lb		3.15 / 6.94	5.00 / 11.02		

1) ALL SPECIFICATIONS ARE SUBJECTED TO CHANGE BY THE MANUFACTURER WITHOUT PRIOR NOTICE.

2) ALL SPECIFICATIONS ARE BEING TESTED AND COMPLY TO ISO 5151.

3) NOMINAL COOLING AND HEATING CAPACITY ARE BASED ON THE CONDITIONS BELOW :

COOLING - 27°C DB / 19°C WB INDOOR AND 35°C DB / 24°C WB OUTDOOR

4) EER/COP CALCULATION IS BASED ON EFFECTIVE POWER INPUT AS PER ISO 5151.

General Data - Heat pump (R22)(Low Static)

MODEL	INDOOR UNIT		MCC 010CR	MCC 015CR	
	OUTDOOR UNIT		MLC 010CR	MLC 015CR	
NOMINAL COOLING CAPACITY	Btu/h		9500	12300	
	W		2780	3600	
NOMINAL HEATING CAPACITY	Btu/h		9500	12300	
	W		2780	3600	
NOMINAL TOTAL INPUT POWER (COOLING)	W		900	1267	
NOMINAL TOTAL INPUT POWER (HEATING)	W		790	1062	
NOMINAL RUNNING CURRENT (COOLING)	A		4.0	5.7	
NOMINAL RUNNING CURRENT (HEATING)	A		3.5	4.8	
POWER SOURCE	V/Ph/Hz		220 - 240 / 1 / 50	220 - 240 / 1 / 50	
EER	W/W		3.17	3.04	
COP	W/W		3.62	3.44	
REFRIGERANT TYPE			R22		
REFRIGERANT CONTROL (EXPANSION DEVICE)			OUTDOOR CAP. TUBE		
INDOOR UNIT	CONTROL	AIR DISCHARGE		DUCTED	
		OPERATION		SLM WIRED HANDSET	
	AIR FLOW	HEIGHT	l/s / CFM	127 / 300	255 / 540
		MEDIUM	l/s / CFM	118 / 250	222 / 470
		LOW	l/s / CFM	99 / 210	165 / 350
	EXTERNAL STATIC PRESSURE (H/M/L)		Pa (in.wg.)	20 / 10 / 5 (0.08 / 0.04 / 0.02)	20 / 10 / 5 (0.08 / 0.04 / 0.02)
	SOUND PRESSURE LEVEL (H/M/L)		dBA	33 / 30 / 26	37 / 34 / 29
	UNIT DIMENSION	HEIGHT	mm/in	261 / 10.3	261 / 10.3
		WIDTH	mm/in	765 / 30.1	905 / 35.6
		DEPTH	mm/in	411 / 16.2	411 / 16.2
	PACKING DIMENSION	HEIGHT	mm/in	376 / 14.8	376 / 14.8
		WIDTH	mm/in	951 / 37.4	1091 / 43.0
		DEPTH	mm/in	541 / 21.3	541 / 21.3
	WEIGHT		kg/lb	17 / 38	21 / 46.3
	CONDENSATE DRAIN SIZE		mm/in	19.1 / 3/4	
AIR FLOW		l/s / CFM	396 / 840	453 / 960	
SOUND PRESSURE LEVEL		dBA	46	49	
UNIT DIMENSION	HEIGHT	mm/in	540 / 21.3		
	WIDTH	mm/in	700 / 27.6		
	DEPTH	mm/in	250 / 9.8		
PACKING DIMENSION	HEIGHT	mm/in	620 / 24.4		
	WIDTH	mm/in	810 / 31.9		
	DEPTH	mm/in	330 / 13.0		
UNIT WEIGHT		kg/lb	32 / 71		
PIPE CONNECTION	TYPE		FLARE VALVE		
	SIZE	LIQUID	mm/in	6.4 / 1/4	6.4 / 1/4
		GAS	mm/in	9.5 / 3/8	12.7 / 1/2
REFRIGERANT CHARGE		kg/lb	0.63 / 1.39	0.60 / 1.32	

1) ALL SPECIFICATIONS ARE SUBJECTED TO CHANGE BY THE MANUFACTURER WITHOUT PRIOR NOTICE.

2) ALL UNITS ARE BEING TESTED AND COMPLY TO ISO 5151.

3) NOMINAL COOLING AND HEATING CAPACITY ARE BASED ON THE CONDITIONS BELOW :

a) COOLING - 27°C DB / 19°C WB INDOOR AND 35°C DB / 24°C WB OUTDOOR

b) HEATING - 20°C DB INDOOR AND 7°C DB / 6°C WB OUTDOOR

4) EER/COP CALCULATION IS BASED ON EFFECTIVE POWER INPUT AS PER ISO 5151.

General Data - Heat pump (R22)(Low Static)

MODEL	INDOOR UNIT		MCC 020CR		
	OUTDOOR UNIT		MLC 018CR	MLC 020CR	
NOMINAL COOLING CAPACITY	Btu/h		18000	19000	
	W		5280	5570	
NOMINAL HEATING CAPACITY	Btu/h		18500	19800	
	W		5420	5800	
NOMINAL TOTAL INPUT POWER (COOLING)	W		1910	1895	
NOMINAL TOTAL INPUT POWER (HEATING)	W		1750	1845	
NOMINAL RUNNING CURRENT (COOLING)	A		8.5	8.3	
NOMINAL RUNNING CURRENT (HEATING)	A		7.8	8.1	
POWER SOURCE	V/Ph/Hz		220 - 240 / 1 / 50	220 - 240 / 1 / 50	
EER	W/W		2.87	3.05	
COP	W/W		3.23	3.27	
REFRIGERANT TYPE			R22		
REFRIGERANT CONTROL (EXPANSION DEVICE)			OUTDOOR CAP. TUBE		
INDOOR UNIT	CONTROL	AIR DISCHARGE		DUCTED	
		OPERATION		SLM WIRED HANDSET	
	AIR FLOW	HIGH	l/s / CFM	307 / 650	
		MEDIUM	l/s / CFM	303 / 640	
		LOW	l/s / CFM	269 / 570	
	EXTERNAL STATIC PRESSURE (H/M/L)		Pa (in.wg.)	29 / 20 / 10 (0.12 / 0.08 / 0.04)	
	SOUND PRESSURE LEVEL (H/M/L)		dBA	38 / 36 / 34	
	UNIT DIMENSION	HEIGHT	mm/in	261 / 10.3	
		WIDTH	mm/in	1065 / 41.9	
		DEPTH	mm/in	411 / 16.2	
	PACKING DIMENSION	HEIGHT	mm/in	376 / 14.8	
		WIDTH	mm/in	1251 / 49.3	
		DEPTH	mm/in	541 / 21.3	
	WEIGHT		kg/lb	22 / 49	
	CONDENSATE DRAIN SIZE		mm/in	19.1 / 3/4	
OUTDOOR UNIT	AIR FLOW		l/s / CFM	614 / 1300	
	SOUND PRESSURE LEVEL		dBA	51	
	UNIT DIMENSION	HEIGHT	mm/in	648 / 25.5	
		WIDTH	mm/in	855 / 33.7	
		DEPTH	mm/in	328 / 12.9	
	PACKING DIMENSION	HEIGHT	mm/in	810 / 31.9	
		WIDTH	mm/in	990 / 39.0	
		DEPTH	mm/in	415 / 16.3	
	UNIT WEIGHT		kg/lb	58 / 128	59 / 130
	PIPE CONNECTION	TYPE		FLARE VALVE	
		SIZE	LIQUID	mm/in	6.4 / 1/4
GAS			mm/in	15.9 / 5/8	
REFRIGERANT CHARGE			kg/lb	1.60 / 3.53	1.35 / 2.98

- 1) ALL SPECIFICATIONS ARE SUBJECTED TO CHANGE BY THE MANUFACTURER WITHOUT PRIOR NOTICE.
- 2) ALL UNITS ARE BEING TESTED AND COMPLY TO ISO 5151.
- 3) NOMINAL COOLING AND HEATING CAPACITY ARE BASED ON THE CONDITIONS BELOW :
 - a) COOLING - 27°C DB / 19°C WB INDOOR AND 35°C DB / 24°C WB OUTDOOR
 - b) HEATING - 20°C DB INDOOR AND 7°C DB / 6°C WB OUTDOOR
- 4) EER/COP CALCULATION IS BASED ON EFFECTIVE POWER INPUT AS PER ISO 5151.

General Data - Heat pump (R22) (Low Static)

MODEL	INDOOR UNIT		MCC 025CR	
	OUTDOOR UNIT		MLC 025CR	
NOMINAL COOLING CAPACITY	Btu/h		23500	
	W		6890	
NOMINAL HEATING CAPACITY	Btu/h		24000	
	W		7030	
NOMINAL TOTAL INPUT POWER (COOLING)	W		2616	
NOMINAL TOTAL INPUT POWER (HEATING)	W		2536	
NOMINAL RUNNING CURRENT (COOLING)	A		11.7	
NOMINAL RUNNING CURRENT (HEATING)	A		11.5	
POWER SOURCE	V/Ph/Hz		220 - 240 / 1 / 50	
EER	W/W		2.70	
COP	W/W		2.84	
REFRIGERANT TYPE			R22	
REFRIGERANT CONTROL (EXPANSION DEVICE)			OUTDOOR CAP. TUBE	
INDOOR UNIT	CONTROL	AIR DISCHARGE		DUCTED
		OPERATION		SLM WIRED HANDSET
	AIR FLOW	HIGH	l/s / CFM	363 / 770
		MEDIUM	l/s / CFM	340 / 720
		LOW	l/s / CFM	274 / 580
	EXTERNAL STATIC PRESSURE (H/M/L)		Pa (in.wg.)	25 / 15 / 5 (0.10 / 0.06 / 0.02)
	SOUND PRESSURE LEVEL (H/M/L)		dBA	40 / 39 / 36
	UNIT DIMENSION	HEIGHT	mm/in	261 / 10.3
		WIDTH	mm/in	1200 / 47.2
		DEPTH	mm/in	411 / 16.2
	PACKING DIMENSION	HEIGHT	mm/in	376 / 14.8
		WIDTH	mm/in	1386 / 54.6
		DEPTH	mm/in	541 / 21.3
	WEIGHT		kg/lb	25 / 55
CONDENSATE DRAIN SIZE		mm/in	19.1 / 3/4	
OUTDOOR UNIT	AIR FLOW		l/s / CFM	755 / 1600
	SOUND PRESSURE LEVEL		dBA	52
	UNIT DIMENSION	HEIGHT	mm/in	750 / 29.5
		WIDTH	mm/in	855 / 33.7
		DEPTH	mm/in	328 / 12.9
	PACKING DIMENSION	HEIGHT	mm/in	810 / 31.9
		WIDTH	mm/in	990 / 39.0
		DEPTH	mm/in	415 / 16.3
	UNIT WEIGHT		kg/lb	62 / 137
	PIPE CONNECTION	TYPE		FLARE VALVE
SIZE		LIQUID	mm/in	9.5 / 3/8
		GAS	mm/in	15.9 / 5/8
REFRIGERANT CHARGE		kg/lb	1.50 / 3.31	

- 1) ALL SPECIFICATIONS ARE SUBJECTED TO CHANGE BY THE MANUFACTURER WITHOUT PRIOR NOTICE.
- 2) ALL UNITS ARE BEING TESTED AND COMPLY TO ISO 5151.
- 3) NOMINAL COOLING AND HEATING CAPACITY ARE BASED ON THE CONDITIONS BELOW :
 - a) COOLING - 27°C DB / 19°C WB INDOOR AND 35°C DB / 24°C WB OUTDOOR
 - b) HEATING - 20°C DB INDOOR AND 7°C DB / 6°C WB OUTDOOR
- 4) EER/COP CALCULATION IS BASED ON EFFECTIVE POWER INPUT AS PER ISO 5151.

General Data - Heat pump (R22) (Low Static)

MODEL	INDOOR UNIT		MCC 030CR		
	OUTDOOR UNIT		MLC 028CR	MLC 030CR	
NOMINAL COOLING CAPACITY- 1Ø / <3Ø>	Btu/h		28000	30000 / <30000>	
	W		8600	8790 / <8790>	
NOMINAL HEATING CAPACITY- 1Ø / <3Ø>	Btu/h		29000	30000 / <30000>	
	W		8500	8790 / <8790>	
NOMINAL TOTAL INPUT POWER (COOLING) - 1Ø / <3Ø>	W		3153	3145 / <3125>	
NOMINAL TOTAL INPUT POWER (HEATING) - 1Ø / <3Ø>	W		2729	3115 / <3095>	
NOMINAL RUNNING CURRENT (COOLING) - 1Ø / <3Ø>	A		15.5	15.0 / <5.2>	
NOMINAL RUNNING CURRENT (HEATING) - 1Ø / <3Ø>	A		13.8	14.9 / <5.1>	
POWER SOURCE - 1Ø / <3Ø>	V/Ph/Hz		220 - 240 / 1 / 50 / <380 - 415 / 3 / 50>		
EER - 1Ø / <3Ø>	W/W		2.79	3.00 / <3.02>	
COP - 1Ø / <3Ø>	W/W		3.38	3.03 / <3.27>	
REFRIGERANT TYPE / CONTROL			R22	R22	
REFRIGERANT CONTROL (EXPANSION DEVICE)			OUTDOOR CAP. TUBE	OUTDOOR CAP. TUBE + TXV	
INDOOR UNIT	CONTROL	AIR DISCHARGE		DUCTED	
		OPERATION		SLM WIRED HANDSET	
	AIR FLOW	SUPER HIGH	l/s / CFM	444 / 940	
		HIGH	l/s / CFM	415 / 880	
		MEDIUM	l/s / CFM	373 / 790	
		LOW	l/s / CFM	349 / 740	
	EXTERNAL STATIC PRESSURE (H/M/L)		Pa (in.wg.)	49 / 39 / 29 / 20 (0.20 / 0.16 / 0.12 / 0.08)	
	SOUND PRESSURE LEVEL (H/M/L)		dBA	49 / 46 / 42 / 38	
	UNIT DIMENSION	HEIGHT	mm/in	378 / 14.9	
		WIDTH	mm/in	929 / 36.6	
		DEPTH	mm/in	541 / 21.3	
	PACKING DIMENSION	HEIGHT	mm/in	415 / 16.3	
		WIDTH	mm/in	1126 / 44.3	
		DEPTH	mm/in	631 / 24.8	
	WEIGHT		kg/lb	39 / 86	
CONDENSATE DRAIN SIZE		mm/in	19.1 / 3/4		
OUTDOOR UNIT	AIR FLOW		l/s / CFM	741 / 1570	1605 / 3400
	SOUND PRESSURE LEVEL		dBA	54	58
	UNIT DIMENSION	HEIGHT	mm/in	750 / 29.5	850 / 33.46
		WIDTH	mm/in	855 / 33.7	1030 / 40.55
		DEPTH	mm/in	328 / 12.9	400 / 15.75
	PACKING DIMENSION	HEIGHT	mm/in	810 / 31.9	1000 / 39.37
		WIDTH	mm/in	990 / 39.0	1200 / 47.24
		DEPTH	mm/in	415 / 16.3	560 / 22.05
	UNIT WEIGHT		kg/lb	68 / 150	95 / 209
	PIPE CONNECTION	TYPE		FLARE VALVE	
SIZE		LIQUID	mm/in	9.5 / 3/8	
		GAS	mm/in	15.9 / 5/8	
REFRIGERANT CHARGE		kg/lb	2.40 / 5.30	2.15 / 4.74	

- 1) ALL SPECIFICATIONS ARE SUBJECTED TO CHANGE BY THE MANUFACTURER WITHOUT PRIOR NOTICE.
- 2) ALL UNITS ARE BEING TESTED AND COMPLY TO ISO 5151.
- 3) NOMINAL COOLING AND HEATING CAPACITY ARE BASED ON THE CONDITIONS BELOW :
 - a) COOLING - 27°C DB / 19°C WB INDOOR AND 35°C DB / 24°C WB OUTDOOR
 - b) HEATING - 20°C DB INDOOR AND 7°C DB / 6°C WB OUTDOOR
- 4) EER/COP CALCULATION IS BASED ON EFFECTIVE POWER INPUT AS PER ISO 5151.

General Data - Heat pump (R22) (Low Static)

MODEL	INDOOR UNIT		MCC 040CR		
	OUTDOOR UNIT		MLC 035CR	MLC 040CR	
NOMINAL COOLING CAPACITY- 1Ø / <3Ø>	Btu/h		33500	40000 / <40000>	
	W		9820	11720 / <11720>	
NOMINAL HEATING CAPACITY- 1Ø / <3Ø>	Btu/h		35000	40000 / <40000>	
	W		10260	11720 / <11720>	
NOMINAL TOTAL INPUT POWER (COOLING) - 1Ø / <3Ø>	W		3265	3728 / <3698>	
NOMINAL TOTAL INPUT POWER (HEATING) - 1Ø / <3Ø>	W		3265	3238 / <3208>	
NOMINAL RUNNING CURRENT (COOLING) - 1Ø / <3Ø>	A		16.4	18.0 / <5.4>	
NOMINAL RUNNING CURRENT (HEATING) - 1Ø / <3Ø>	A		16.4	16.6 / <4.0>	
POWER SOURCE - 1Ø / <3Ø>	V/Ph/Hz		220 - 240 / 1 / 50 / <380 - 415 / 3 / 50>		
EER - 1Ø / <3Ø>	W/W		3.30	3.41 / <3.44>	
COP - 1Ø / <3Ø>	W/W		3.45	3.98 / <4.02>	
REFRIGERANT TYPE / CONTROL			R22		
REFRIGERANT CONTROL (EXPANSION DEVICE)			OUTDOOR CAP. TUBE + TXV		
INDOOR UNIT	CONTROL	AIR DISCHARGE		DUCTED	
		OPERATION		SLM WIRED HANDSET	
	AIR FLOW	SUPER HIGH	l/s / CFM	562 / 1190	
		HIGH	l/s / CFM	500 / 1060	
		MEDIUM	l/s / CFM	472 / 1000	
		LOW	l/s / CFM	458 / 970	
	EXTERNAL STATIC PRESSURE (H/M/L)		Pa (in.wg.)	49 / 39 / 29 / 20 (0.20 / 0.16 / 0.12 / 0.08)	
	SOUND PRESSURE LEVEL (H/M/L)		dBA	51 / 49 / 45 / 41	
	UNIT DIMENSION	HEIGHT	mm/in	378 / 14.9	
		WIDTH	mm/in	1045 / 41.1	
		DEPTH	mm/in	541 / 21.3	
	PACKING DIMENSION	HEIGHT	mm/in	415 / 16.3	
		WIDTH	mm/in	1245 / 49.0	
		DEPTH	mm/in	631 / 24.8	
	WEIGHT		kg/lb	42 / 93	
CONDENSATE DRAIN SIZE		mm/in	19.1 / 3/4		
OUTDOOR UNIT	AIR FLOW		l/s / CFM	1605 / 3400	1605 / 3400
	SOUND PRESSURE LEVEL		dBA	58	58
	UNIT DIMENSION	HEIGHT	mm/in	850 / 33.5	
		WIDTH	mm/in	1030 / 40.6	
		DEPTH	mm/in	400 / 15.8	
	PACKING DIMENSION	HEIGHT	mm/in	1000 / 39.4	
		WIDTH	mm/in	1200 / 47.2	
		DEPTH	mm/in	560 / 22.1	
	UNIT WEIGHT		kg/lb	95 / 209	100 / 221
	PIPE CONNECTION	TYPE		FLARE VALVE	
SIZE		LIQUID	mm/in	9.5 / 3/8	
		GAS	mm/in	19.1 / 3/4	
REFRIGERANT CHARGE		kg/lb	2.60 / 5.73	2.60 / 5.73	

- 1) ALL SPECIFICATIONS ARE SUBJECTED TO CHANGE BY THE MANUFACTURER WITHOUT PRIOR NOTICE.
- 2) ALL UNITS ARE BEING TESTED AND COMPLY TO ISO 5151.
- 3) NOMINAL COOLING AND HEATING CAPACITY ARE BASED ON THE CONDITIONS BELOW :
 - a) COOLING - 27°C DB / 19°C WB INDOOR AND 35°C DB / 24°C WB OUTDOOR
 - b) HEATING - 20°C DB INDOOR AND 7°C DB / 6°C WB OUTDOOR
- 4) EER/COP CALCULATION IS BASED ON EFFECTIVE POWER INPUT AS PER ISO 5151.

General Data - Heat pump (R22) (Low Static)

MODEL	INDOOR UNIT		MCC 050CR	MCC 060CR	
	OUTDOOR UNIT		MLC 050CR	MLC 061CR	
NOMINAL COOLING CAPACITY	Btu/h		50000	56000	
	W		14650	16410	
NOMINAL HEATING CAPACITY	Btu/h		53000	56000	
	W		15530	16410	
NOMINAL TOTAL INPUT POWER (COOLING)	W		5047	6010	
NOMINAL TOTAL INPUT POWER (HEATING)	W		4447	4980	
NOMINAL RUNNING CURRENT (COOLING)	A		9.0	10.0	
NOMINAL RUNNING CURRENT (HEATING)	A		6.0	8.8	
POWER SOURCE	V/Ph/Hz		380 - 415 / 3 / 50		
EER	W/W		3.11	2.91	
COP	W/W		3.78	3.57	
REFRIGERANT TYPE			R22	R22	
REFRIGERANT CONTROL (EXPANSION DEVICE)			OUTDOOR CAP. TUBE + TXV	INDOOR & OUTDOOR CAP. TUBE	
INDOOR UNIT	CONTROL	AIR DISCHARGE		DUCTED	
		OPERATION		SLM WIRED HANDSET	
	AIR FLOW	SUPER HIGH	l/s / CFM	713 / 1510	802 / 1700
		HIGH	l/s / CFM	628 / 1330	765 / 1620
		MEDIUM	l/s / CFM	618 / 1310	717 / 1520
		LOW	l/s / CFM	599 / 1270	693 / 1470
	EXTERNAL STATIC PRESSURE (H/M/L)	Pa (in.wg.)	78 / 59 / 39 / 20 (0.31 / 0.24 / 0.16 / 0.08)		69 / 49 / 29 / 20 (0.28 / 0.20 / 0.12 / 0.08)
	SOUND PRESSURE LEVEL (H/M/L)	dBA	53 / 52 / 50 / 47		55 / 53 / 50 / 47
	UNIT DIMENSION	HEIGHT	mm/in	378 / 14.9	378 / 14.9
		WIDTH	mm/in	1299 / 51.1	1499 / 59.0
		DEPTH	mm/in	541 / 21.3	541 / 21.3
	PACKING DIMENSION	HEIGHT	mm/in	415 / 16.3	415 / 16.3
		WIDTH	mm/in	1497 / 59.0	1701 / 67.0
		DEPTH	mm/in	631 / 24.8	631 / 24.8
	WEIGHT	kg/lb	54 / 119	62 / 137	
CONDENSATE DRAIN SIZE	mm/in	19.1 / 3/4			
OUTDOOR UNIT	AIR FLOW	l/s / CFM	1605 / 3400	1793 / 3800	
	SOUND PRESSURE LEVEL	dBA	58	61	
	UNIT DIMENSION	HEIGHT	mm/in	850 / 33.5	850 / 33.5
		WIDTH	mm/in	1030 / 40.6	1030 / 40.6
		DEPTH	mm/in	400 / 15.8	460 / 18.1
	PACKING DIMENSION	HEIGHT	mm/in	1000 / 39.4	1016 / 40.0
		WIDTH	mm/in	1200 / 47.2	1178 / 46.4
		DEPTH	mm/in	560 / 22.1	602 / 23.7
	UNIT WEIGHT	kg/lb	105 / 231	108 / 238	
	PIPE CONNECTION	TYPE		FLARE VALVE	
SIZE		LIQUID	mm/in	9.5 / 3/8	12.7 / 1/2
		GAS	mm/in	19.1 / 3/4	19.1 / 3/4
REFRIGERANT CHARGE	kg/lb	2.75 / 5.73	5.00 / 11.02		

- 1) ALL SPECIFICATIONS ARE SUBJECTED TO CHANGE BY THE MANUFACTURER WITHOUT PRIOR NOTICE.
- 2) ALL UNITS ARE BEING TESTED AND COMPLY TO ISO 5151.
- 3) NOMINAL COOLING AND HEATING CAPACITY ARE BASED ON THE CONDITIONS BELOW :
 - a) COOLING - 27°C DB / 19°C WB INDOOR AND 35°C DB / 24°C WB OUTDOOR
 - b) HEATING - 20°C DB INDOOR AND 7°C DB / 6°C WB OUTDOOR
- 4) EER/COP CALCULATION IS BASED ON EFFECTIVE POWER INPUT AS PER ISO 5151.

Components Data (R22)

MODEL	INDOOR UNIT		MCC 010C	MCC 015C		
	OUTDOOR UNIT		MLC 010C	MLC 015C		
INDOOR FAN	TYPE		CENTRIFUGAL			
	QUANTITY		1	2		
	MATERIAL		GALVANIZED STEEL			
	DRIVE		DIRECT			
	DIAMETER	mm/in	160 / 6.30			
	LENGTH	mm/in	202 / 7.95			
INDOOR FAN MOTOR	TYPE		INDUCTION			
	QUANTITY		1			
	INDEX OF PROTECTION (IP)		N/A			
OUTDOOR FAN	TYPE		PROPELLER			
	QUANTITY		1			
	MATERIAL		GLASS REINFORCED ACRYL STYRENE RESIN			
	DRIVE		DIRECT			
	DIAMETER	mm/in	404 / 16			
OUTDOOR FAN MOTOR	TYPE		INDUCTION			
	QUANTITY		1			
	INDEX OF PROTECTION (IP)		IP54			
COMPRESSOR	TYPE		ROTARY			
	OIL TYPE		ATMOS NM56M or SUNISO 4GDID			
	OIL AMOUNT	cm ³ / fl.oz.	320 / 11.3	350 / 11.8		
INDOOR COIL	TUBE	MATERIAL		SEAMLESS COPPER		
		DIAMETER	mm/in	9.52 / 3/8		
		THICKNESS	mm/in	0.35 / 0.014		
	FIN	MATERIAL		ALUMINIUM (CORR. FIN)	ALUMINIUM (CORR. FIN)	
		THICKNESS	mm/in	0.11 / 0.0043	0.11 / 0.0043	
		FACE AREA	m ² /ft ²	0.115 / 1.238	0.143 / 1.542	
		ROW		3	3	
		FIN PER INCH		12	14	
OUTDOOR COIL	TUBE	MATERIAL		SEAMLESS INNER GROOVE COPPER		
		DIAMETER	mm/in	7.00 / 0.276		
		THICKNESS	mm/in	0.28 / 0.011		
	FIN	MATERIAL		ALUMINIUM (RAISE LANCE)		
		THICKNESS	mm/in	0.10 / 0.004		
		FACE AREA	m ² /ft ²	0.36 / 3.88		
		ROW		1		
		FIN PER INCH		20		
AIR QUALITY	FILTER	TYPE		WASHABLE SARANET FILTER		
		QUANTITY	pc	1		
		LENGTH	mm/in	560 / 22.05	700 / 27.56	
		WIDTH	mm/in	195 / 7.68		
		THICKNESS	mm/in	5 / 0.20		
CASING	INDOOR UNIT	MATERIAL		GALVANIZED STEEL		
		FINISHING		WITH PE INSULATION		
		COLOUR		WITHOUT POWDER PAINT		
	OUTDOOR UNIT	MATERIAL		GALVANIZED MILD STEEL		
		FINISHING		POLYESTER POWDER		
		COLOUR		LIGHT GREY		

1) ALL SPECIFICATIONS ARE SUBJECTED TO CHANGE BY THE MANUFACTURER WITHOUT PRIOR NOTICE.

Components Data (R22)

MODEL	INDOOR UNIT		MCC 020C		
	OUTDOOR UNIT		MLC 018C	MLC 020C	
INDOOR FAN	TYPE		CENTRIFUGAL		
	QUANTITY		2		
	MATERIAL		GALVANIZED STEEL		
	DRIVE		DIRECT		
	DIAMETER	mm/in	160 / 6.30		
	LENGTH	mm/in	202 / 7.95		
INDOOR FAN MOTOR	TYPE		INDUCTION		
	QUANTITY		1		
	INDEX OF PROTECTION (IP)		N/A		
OUTDOOR FAN	TYPE		PROPELLER		
	QUANTITY		1		
	MATERIAL		GLASS REINFORCED ACRYL STYRENE RESIN		
	DRIVE		DIRECT		
	DIAMETER	mm/in	457 / 18		
OUTDOOR FAN MOTOR	TYPE		INDUCTION		
	QUANTITY		1		
	INDEX OF PROTECTION (IP)		IP54		
COMPRESSOR	TYPE		ROTARY		
	OIL TYPE		ATMOS NM56M or SUNISO 4GDID		
	OIL AMOUNT	cm ³ / fl.oz.	670 / 23.6		
INDOOR COIL	TUBE	MATERIAL		SEAMLESS COPPER	
		DIAMETER	mm/in	9.52 / 3/8	
		THICKNESS	mm/in	0.35 / 0.014	
	FIN	MATERIAL		ALUMINIUM (CORR. FIN)	
		THICKNESS	mm/in	0.11 / 0.0043	
		FACE AREA	m ² /ft ²	0.176 / 1.892	
		ROW		3	
		FIN PER INCH		12	
OUTDOOR COIL	TUBE	MATERIAL		SEAMLESS INNER GROOVE COPPER	
		DIAMETER	mm/in	7.00 / 0.276	
		THICKNESS	mm/in	0.28 / 0.011	
	FIN	MATERIAL		ALUMINIUM (RAISE LANCE)	
		THICKNESS	mm/in	0.10 / 0.004	
		FACE AREA	m ² /ft ²	0.52 / 5.59	
		ROW		1	2
		FIN PER INCH		20	24
AIR QUALITY	FILTER	TYPE		WASHABLE SARANET FILTER	
		QUANTITY	pc	1	
		LENGTH	mm/in	860 / 33.86	
		WIDTH	mm/in	195 / 7.68	
		THICKNESS	mm/in	5 / 0.20	
CASING	INDOOR UNIT		MATERIAL	GALVANIZED STEEL	
			FINISHING	WITH PE INSULATION	
			COLOUR	WITHOUT POWDER PAINT	
	OUTDOOR UNIT		MATERIAL	GALVANIZED MILD STEEL	
			FINISHING	POLYESTER POWDER	
			COLOUR	LIGHT GREY	

1) ALL SPECIFICATIONS ARE SUBJECTED TO CHANGE BY THE MANUFACTURER WITHOUT PRIOR NOTICE.

Components Data (R22)

MODEL	INDOOR UNIT		MCC 025C		
	OUTDOOR UNIT		MLC 025C		
INDOOR FAN	TYPE		CENTRIFUGAL		
	QUANTITY		2		
	MATERIAL		GALVANIZED STEEL		
	DRIVE		DIRECT		
	DIAMETER	mm/in	160 / 6.30		
	LENGTH	mm/in	202 / 7.95		
INDOOR FAN MOTOR	TYPE		INDUCTION		
	QUANTITY		1		
	INDEX OF PROTECTION (IP)		N/A		
OUTDOOR FAN	TYPE		PROPELLER		
	QUANTITY		1		
	MATERIAL		GLASS REINFORCED ACRYL STYRENE RESIN		
	DRIVE		DIRECT		
	DIAMETER	mm/in	457 / 18		
OUTDOOR FAN MOTOR	TYPE		INDUCTION		
	QUANTITY		1		
	INDEX OF PROTECTION (IP)		IP54		
COMPRESSOR	TYPE		ROTARY		
	OIL TYPE		ATMOS NM56M or SUNISO 4GDID		
	OIL AMOUNT	cm ³ / fl.oz.	700 / 24.6		
INDOOR COIL	TUBE	MATERIAL		SEAMLESS INNER GROOVE COPPER	
		DIAMETER	mm/in	9.52 / 3/8	
		THICKNESS	mm/in	0.33 / 0.013	
	FIN	MATERIAL		ALUMINIUM (CORR. FIN)	
		THICKNESS	mm/in	0.11 / 0.0043	
		FACE AREA	m ² /ft ²	0.203 / 2.187	
		ROW		3	
		FIN PER INCH		12	
OUTDOOR COIL	TUBE	MATERIAL		SEAMLESS INNER GROOVE COPPER	
		DIAMETER	mm/in	7.00 / 0.276	
		THICKNESS	mm/in	0.28 / 0.011	
	FIN	MATERIAL		ALUMINIUM (RAISE LANCE)	
		THICKNESS	mm/in	0.10 / 0.004	
		FACE AREA	m ² /ft ²	0.62 / 6.67	
		ROW		2	
		FIN PER INCH		18	
AIR QUALITY	FILTER	TYPE		WASHABLE SARANET FILTER	
		QUANTITY	pc	1	
		SIZE	LENGTH	mm/in	995 / 39.17
			WIDTH	mm/in	195 / 7.68
			THICKNESS	mm/in	5 / 0.20
		CASING	INDOOR UNIT	MATERIAL	GALVANIZED STEEL
FINISHING	WITH PE INSULATION				
COLOUR	WITHOUT POWDER PAINT				
OUTDOOR UNIT	MATERIAL		GALVANIZED MILD STEEL		
	FINISHING		POLYESTER POWDER		
	COLOUR		LIGHT GREY		

1) ALL SPECIFICATIONS ARE SUBJECTED TO CHANGE BY THE MANUFACTURER WITHOUT PRIOR NOTICE.

Components Data (R22)

MODEL	INDOOR UNIT		MCC 028C		
	OUTDOOR UNIT		MLC 028C	MLC 030C	
INDOOR FAN	TYPE		CENTRIFUGAL		
	QUANTITY		2		
	MATERIAL		GALVANIZED STEEL		
	DRIVE		DIRECT		
	DIAMETER	mm/in	185 / 7.28		
	LENGTH	mm/in	203 / 7.99		
INDOOR FAN MOTOR	TYPE		INDUCTION		
	QUANTITY		1		
	INDEX OF PROTECTION (IP)		N/A		
OUTDOOR FAN	TYPE		PROPELLER		
	QUANTITY		1		
	MATERIAL		GLASS REINFORCED ACRYL STYRENE RESIN		
	DRIVE		DIRECT		
	DIAMETER	mm/in	457 / 18	609.6 / 24	
OUTDOOR FAN MOTOR	TYPE		INDUCTION		
	QUANTITY		1		
	INDEX OF PROTECTION (IP)		IP54	-	
COMPRESSOR	TYPE		ROTARY	SCROLL	
	OIL TYPE		ATMOS M60 or SUNISO 4GDID	MINERAL (Sontex 200 LT)	
	OIL AMOUNT	cm ³ / fl.oz.	1130 / 39.8	1240 / 43.6	
INDOOR COIL	TUBE	MATERIAL		SEAMLESS COPPER	
		DIAMETER	mm/in	9.52 / 3/8	
		THICKNESS	mm/in	0.36 / 0.014	
	FIN	MATERIAL		ALUMINIUM (CORR. FIN)	
		THICKNESS	mm/in	0.127 / 0.005	
		FACE AREA	m ² /ft ²	0.24 / 2.62	
		ROW		3	
		FIN PER INCH		14	
OUTDOOR COIL	TUBE	MATERIAL		SEAMLESS INNER GROOVE COPPER	SEAMLESS COPPER
		DIAMETER	mm/in	9.52 / 3/8	9.52 / 3/8
		THICKNESS	mm/in	0.33 / 0.013	0.35 / 0.014
	FIN	MATERIAL		ALUMINIUM (SLIT FIN)	
		THICKNESS	mm/in	0.12 / 0.005	
		FACE AREA	m ² /ft ²	0.61 / 6.52	
		ROW		2	1
		FIN PER INCH		18	16
	AIR QUALITY	FILTER	TYPE		WASHABLE SARANET FILTER
QUANTITY			pc	2	
LENGTH			mm/in	456 / 17.95	
WIDTH			mm/in	210 / 8.27	
THICKNESS			mm/in	5 / 0.20	
CASING	INDOOR UNIT	MATERIAL		GALVANIZED STEEL	
		FINISHING		WITH PE INSULATION	
		COLOUR		WITHOUT POWDER PAINT	
	OUTDOOR UNIT	MATERIAL		GALVANIZED MILD STEEL	
		FINISHING		POLYESTER POWDER	
		COLOUR		LIGHT GREY	

1) ALL SPECIFICATIONS ARE SUBJECTED TO CHANGE BY THE MANUFACTURER WITHOUT PRIOR NOTICE.

Components Data (R22)

MODEL	INDOOR UNIT			MCC 038C			
	OUTDOOR UNIT			MLC 035C		MLC 040C	
INDOOR FAN	TYPE			CENTRIFUGAL			
	QUANTITY			2			
	MATERIAL			GALVANIZED STEEL			
	DRIVE			DIRECT			
	DIAMETER		mm/in	214 / 8.43			
	LENGTH		mm/in	203.2 / 8.00			
INDOOR FAN MOTOR	TYPE			INDUCTION			
	QUANTITY			1			
	INDEX OF PROTECTION (IP)			N/A			
OUTDOOR FAN	TYPE			PROPELLER			
	QUANTITY			1			
	MATERIAL			GLASS REINFORCED ACRYL STYRENE RESIN			
	DRIVE			DIRECT			
	DIAMETER		mm/in	609.6 / 24			
OUTDOOR FAN MOTOR	TYPE			INDUCTION			
	QUANTITY			1			
	INDEX OF PROTECTION (IP)			-			
COMPRESSOR	TYPE			SCROLL			
	OIL TYPE			MINERAL (Sortex 200 LT)		MINERAL (Sortex 200 LT)	
	OIL AMOUNT		cm ³ / fl.oz.	1240 / 43.6		1240 / 43.6	
INDOOR COIL	TUBE	MATERIAL			SEAMLESS COPPER		
		DIAMETER		mm/in	9.52 / 3/8		
		THICKNESS		mm/in	0.36 / 0.014		
	FIN	MATERIAL			ALUMINIUM (CORR. FIN)		
		THICKNESS		mm/in	0.127 / 0.005		
		FACE AREA		m ² /ft ²	0.34 / 3.61		
		ROW			3		
		FIN PER INCH			14		
OUTDOOR COIL	TUBE	MATERIAL			SEAMLESS COPPER		
		DIAMETER		mm/in	9.52 / 3/8		
		THICKNESS		mm/in	0.35 / 0.014		
	FIN	MATERIAL			ALUMINIUM (SLIT FIN)	ALUMINIUM (CORR. FIN)	
		THICKNESS		mm/in	0.127 / 0.005	0.127 / 0.005	
		FACE AREA		m ² /ft ²	0.87 / 9.33	0.87 / 9.33	
		ROW			1	2	
		FIN PER INCH			16	14	
AIR QUALITY	FILTER	TYPE			WASHABLE SARANET FILTER		
		QUANTITY		pc	2		
		SIZE	LENGTH		mm/in	608 / 23.94	
			WIDTH		mm/in	230 / 9.06	
			THICKNESS		mm/in	5 / 0.20	
CASING	INDOOR UNIT		MATERIAL		GALVANIZED STEEL		
			FINISHING		WITH PE INSULATION		
			COLOUR		WITHOUT POWDER PAINT		
	OUTDOOR UNIT		MATERIAL		GALVANIZED MILD STEEL		
			FINISHING		POLYESTER POWDER		
			COLOUR		LIGHT GREY		

1) ALL SPECIFICATIONS ARE SUBJECTED TO CHANGE BY THE MANUFACTURER WITHOUT PRIOR NOTICE.

Components Data (R22)

MODEL	INDOOR UNIT		MCC 030C			
	OUTDOOR UNIT		MLC 028C	MLC 030C		
INDOOR FAN	TYPE		CENTRIFUGAL			
	QUANTITY		2			
	MATERIAL		GALVANIZED STEEL			
	DRIVE		DIRECT			
	DIAMETER	mm/in	214 / 8.43			
	LENGTH	mm/in	203.2 / 8.00			
INDOOR FAN MOTOR	TYPE		INDUCTION			
	QUANTITY		1			
	INDEX OF PROTECTION (IP)		N/A			
OUTDOOR FAN	TYPE		PROPELLER			
	QUANTITY		1			
	MATERIAL		GLASS REINFORCED ACRYL STYRENE RESIN			
	DRIVE		DIRECT			
	DIAMETER	mm/in	457 / 18	609.6 / 24		
OUTDOOR FAN MOTOR	TYPE		INDUCTION			
	QUANTITY		1			
	INDEX OF PROTECTION (IP)		IP54	-		
COMPRESSOR	TYPE		ROTARY	SCROLL		
	OIL TYPE		ATMOS M60 or SUNISO 4GDID	MINERAL (Sontex 200 LT)		
	OIL AMOUNT	cm ³ / fl.oz.	1130 / 39.8	1240 / 43.6		
INDOOR COIL	TUBE	MATERIAL		SEAMLESS COPPER		
		DIAMETER	mm/in	9.52 / 3/8		
		THICKNESS	mm/in	0.36 / 0.014		
	FIN	MATERIAL		ALUMINIUM (CORR. FIN)		
		THICKNESS	mm/in	0.127 / 0.005		
		FACE AREA	m ² /ft ²	0.277 / 2.98		
		ROW	3			
		FIN PER INCH	12			
OUTDOOR COIL	TUBE	MATERIAL		SEAMLESS INNER GROOVE COPPER	SEAMLESS COPPER	
		DIAMETER	mm/in	9.52 / 3/8	9.52 / 3/8	
		THICKNESS	mm/in	0.33 / 0.013	0.35 / 0.014	
	FIN	MATERIAL		ALUMINIUM (SLIT FIN)	ALUMINIUM (SLIT FIN)	
		THICKNESS	mm/in	0.127 / 0.005	0.127 / 0.005	
		FACE AREA	m ² /ft ²	0.61 / 6.52	0.87 / 9.33	
		ROW	2			
		FIN PER INCH	18			
	AIR QUALITY	FILTER	TYPE		WASHABLE SARANET FILTER	
QUANTITY			pc	2		
SIZE			LENGTH	mm/in	449 / 17.68	
			WIDTH	mm/in	305 / 12.01	
			THICKNESS	mm/in	5 / 0.20	
CASING	INDOOR UNIT	MATERIAL	GALVANIZED STEEL			
		FINISHING	WITH PE INSULATION			
		COLOUR	WITHOUT POWER PAINT			
	OUTDOOR UNIT	MATERIAL	GALVANIZED MILD STEEL			
		FINISHING	POLYESTER POWDER			
		COLOUR	LIGHT GREY			

1) ALL SPECIFICATIONS ARE SUBJECTED TO CHANGE BY THE MANUFACTURER WITHOUT PRIOR NOTICE.

Components Data (R22)

MODEL	INDOOR UNIT		MCC 040C			
	OUTDOOR UNIT		MLC 035C	MLC 040C		
INDOOR FAN	TYPE		CENTRIFUGAL			
	QUANTITY		2			
	MATERIAL		GALVANIZED STEEL			
	DRIVE		DIRECT			
	DIAMETER	mm/in	214 / 8.43			
	LENGTH	mm/in	203.2 / 8.00			
INDOOR FAN MOTOR	TYPE		INDUCTION			
	QUANTITY		1			
	INDEX OF PROTECTION (IP)		N/A			
OUTDOOR FAN	TYPE		PROPELLER			
	QUANTITY		1			
	MATERIAL		GLASS REINFORCED ACRYL STYRENE RESIN			
	DRIVE		DIRECT			
	DIAMETER	mm/in	609.6 / 24			
OUTDOOR FAN MOTOR	TYPE		INDUCTION			
	QUANTITY		1			
	INDEX OF PROTECTION (IP)		-			
COMPRESSOR	TYPE		SCROLL			
	OIL TYPE		MINERAL (Sortex 200 LT)	MINERAL (Sortex 200 LT)		
	OIL AMOUNT	cm ³ / fl.oz.	1240 / 43.6	1240 / 43.6		
INDOOR COIL	TUBE	MATERIAL		SEAMLESS COPPER		
		DIAMETER	mm/in	9.52 / 3/8		
		THICKNESS	mm/in	0.36 / 0.014		
	FIN	MATERIAL		ALUMINIUM (CORR. FIN)		
		THICKNESS	mm/in	0.127 / 0.005		
		FACE AREA	m ² /ft ²	0.31 / 3.44		
		ROW		3		
		FIN PER INCH		14		
OUTDOOR COIL	TUBE	MATERIAL		SEAMLESS COPPER		
		DIAMETER	mm/in	9.52 / 3/8		
		THICKNESS	mm/in	0.35 / 0.014		
	FIN	MATERIAL		ALUMINIUM (SLIT FIN)	ALUMINIUM (CORR. FIN)	
		THICKNESS	mm/in	0.127 / 0.005	0.127 / 0.005	
		FACE AREA	m ² /ft ²	0.87 / 9.33	0.87 / 9.33	
		ROW		1	2	
		FIN PER INCH		16	14	
AIR QUALITY	FILTER	TYPE		WASHABLE SARANET FILTER		
		QUANTITY	pc	2		
		SIZE	LENGTH	mm/in	507 / 19.96	
			WIDTH	mm/in	305 / 12.01	
			THICKNESS	mm/in	5 / 0.20	
CASING	INDOOR UNIT	MATERIAL	GALVANIZED STEEL			
		FINISHING	WITH PE INSULATION			
		COLOUR	WITHOUT POWDER PAINT			
	OUTDOOR UNIT	MATERIAL	GALVANIZED MILD STEEL			
		FINISHING	POLYESTER POWDER			
		COLOUR	LIGHT GREY			

1) ALL SPECIFICATIONS ARE SUBJECTED TO CHANGE BY THE MANUFACTURER WITHOUT PRIOR NOTICE.

Components Data (R22)

MODEL	INDOOR UNIT		MCC 050C	MCC 060C		
	OUTDOOR UNIT		MLC 050C	MLC 061C		
INDOOR FAN	TYPE		CENTRIFUGAL			
	QUANTITY		2			
	MATERIAL		GALVANIZED STEEL			
	DRIVE		DIRECT			
	DIAMETER	mm/in	214 / 8.43			
	LENGTH	mm/in	203.2 / 8.00			
INDOOR FAN MOTOR	TYPE		INDUCTION			
	QUANTITY		1			
	INDEX OF PROTECTION (IP)		N/A			
OUTDOOR FAN	TYPE		PROPELLER			
	QUANTITY		1			
	MATERIAL		GLASS REINFORCED ACRYL STYRENE RESIN			
	DRIVE		DIRECT			
	DIAMETER	mm/in	609.6 / 24			
OUTDOOR FAN MOTOR	TYPE		INDUCTION			
	QUANTITY		1			
	INDEX OF PROTECTION (IP)		-			
COMPRESSOR	TYPE		SCROLL			
	OIL TYPE		MINERAL (Sortex 200 LT)	MINERAL (Sortex 200 LT)		
	OIL AMOUNT	cm ³ / fl.oz.	1950 / 68.6	1705 / 60.0		
INDOOR COIL	TUBE	MATERIAL		SEAMLESS COPPER		
		DIAMETER	mm/in	9.52 / 3/8		
		THICKNESS	mm/in	0.35 / 0.014		
	FIN	MATERIAL		ALUMINIUM (CORR. FIN)	ALUMINIUM (CORR. FIN)	
		THICKNESS	mm/in	0.127 / 0.005	0.127 / 0.005	
		FACE AREA	m ² /ft ²	0.40 / 4.40	0.47 / 5.16	
		ROW		3	3	
		FIN PER INCH		14	14	
OUTDOOR COIL	TUBE	MATERIAL		SEAMLESS COPPER	SEAMLESS INNER GROOVED COPPER	
		DIAMETER	mm/in	9.52 / 3/8	9.52 / 3/8	
		THICKNESS	mm/in	0.35 / 0.014	0.33 / 0.013	
	FIN	MATERIAL		ALUMINIUM (CORR. FIN)	ALUMINIUM (SLIT FIN)	
		THICKNESS	mm/in	0.127 / 0.005	0.127 / 0.005	
		FACE AREA	m ² /ft ²	0.87 / 9.33	0.84 / 9.04	
		ROW		2	3	
		FIN PER INCH		16	14	
AIR QUALITY	FILTER	TYPE		WASHABLE SARANET FILTER		
		QUANTITY		2		
		SIZE	LENGTH	mm/in	634 / 24.96	734 / 28.90
			WIDTH	mm/in	305 / 12.01	305 / 12.01
			THICKNESS	mm/in	5 / 0.20	5 / 0.20
CASING	INDOOR UNIT	MATERIAL	GALVANIZED STEEL			
		FINISHING	WITH PE INSULATION			
		COLOUR	WITHOUT POWDER PAINT			
	OUTDOOR UNIT	MATERIAL	GALVANIZED MILD STEEL			
		FINISHING	POLYESTER POWDER			
		COLOUR	LIGHT GREY			

1) ALL SPECIFICATIONS ARE SUBJECTED TO CHANGE BY THE MANUFACTURER WITHOUT PRIOR NOTICE.

Components Data (R22)

MODEL	INDOOR UNIT		MCC 010CR	MCC 015CR		
	OUTDOOR UNIT		MLC 010CR	MLC 015CR		
INDOOR FAN	TYPE		CENTRIFUGAL			
	QUANTITY		1	2		
	MATERIAL		GALVANIZED STEEL			
	DRIVE		DIRECT			
	DIAMETER	mm/in	160 / 6.30			
	LENGTH	mm/in	202 / 7.95			
INDOOR FAN MOTOR	TYPE		INDUCTION			
	QUANTITY		1			
	INDEX OF PROTECTION (IP)		N/A			
OUTDOOR FAN	TYPE		PROPELLER			
	QUANTITY		1			
	MATERIAL		GLASS REINFORCED ACRYL STYRENE RESIN			
	DRIVE		DIRECT			
	DIAMETER	mm/in	404 / 16			
OUTDOOR FAN MOTOR	TYPE		INDUCTION			
	QUANTITY		1			
	INDEX OF PROTECTION (IP)		IP54			
COMPRESSOR	TYPE		ROTARY			
	OIL TYPE		ATMOS NM56M or SUNISO 4GDID			
	OIL AMOUNT	cm ³ / fl.oz.	320 / 11.3	350 / 11.8		
INDOOR COIL	TUBE	MATERIAL		SEAMLESS COPPER		
		DIAMETER	mm/in	9.52 / 3/8		
		THICKNESS	mm/in	0.35 / 0.014		
	FIN	MATERIAL		ALUMINIUM (CORR. FIN)	ALUMINIUM (CORR. FIN)	
		THICKNESS	mm/in	0.11 / 0.0043	0.11 / 0.0043	
		FACE AREA	m ² /ft ²	0.115 / 1.238	0.143 / 1.542	
		ROW		3	3	
		FIN PER INCH		12	14	
OUTDOOR COIL	TUBE	MATERIAL		SEAMLESS INNER GROOVE COPPER		
		DIAMETER	mm/in	7.00 / 0.276		
		THICKNESS	mm/in	0.28 / 0.011		
	FIN	MATERIAL		ALUMINIUM (RAISE LANCE)		
		THICKNESS	mm/in	0.10 / 0.004		
		FACE AREA	m ² /ft ²	0.36 / 3.88		
		ROW		1		
		FIN PER INCH		20		
AIR QUALITY	FILTER	TYPE		WASHABLE SARANET FILTER		
		QUANTITY	pc	1		
		SIZE	LENGTH	mm/in	560 / 22.05	
			WIDTH	mm/in	195 / 7.68	
			THICKNESS	mm/in	5 / 0.20	
		CASING	INDOOR UNIT	MATERIAL		GALVANIZED STEEL
FINISHING				WITH PE INSULATION		
COLOUR				WITHOUT POWDER PAINT		
OUTDOOR UNIT	MATERIAL		GALVANIZED MILD STEEL			
	FINISHING		POLYESTER POWDER			
	COLOUR		LIGHT GREY			

1) ALL SPECIFICATIONS ARE SUBJECTED TO CHANGE BY THE MANUFACTURER WITHOUT PRIOR NOTICE.

Components Data (R22)

MODEL	INDOOR UNIT		MCC 020CR			
	OUTDOOR UNIT		MLC 018CR	MLC 020CR		
INDOOR FAN	TYPE		CENTRIFUGAL			
	QUANTITY		2			
	MATERIAL		GALVANIZED STEEL			
	DRIVE		DIRECT			
	DIAMETER	mm/in	160 / 6.30			
	LENGTH	mm/in	202 / 7.95			
INDOOR FAN MOTOR	TYPE		INDUCTION			
	QUANTITY		1			
	INDEX OF PROTECTION (IP)		N/A			
OUTDOOR FAN	TYPE		PROPELLER			
	QUANTITY		1			
	MATERIAL		GLASS REINFORCED ACRYL STYRENE RESIN			
	DRIVE		DIRECT			
	DIAMETER	mm/in	457 / 18			
OUTDOOR FAN MOTOR	TYPE		INDUCTION			
	QUANTITY		1			
	INDEX OF PROTECTION (IP)		IP54			
COMPRESSOR	TYPE		ROTARY			
	OIL TYPE		ATMOS NM56M or SUNISO 4GDID			
	OIL AMOUNT	cm ³ / fl.oz.	670 / 23.6			
INDOOR COIL	TUBE	MATERIAL		SEAMLESS COPPER		
		DIAMETER	mm/in	9.52 / 3/8		
		THICKNESS	mm/in	0.35 / 0.014		
	FIN	MATERIAL		ALUMINIUM (CORR. FIN)		
		THICKNESS	mm/in	0.11 / 0.0043		
		FACE AREA	m ² /ft ²	0.176 / 1.892		
		ROW		3		
FIN PER INCH		12				
OUTDOOR COIL	TUBE	MATERIAL		SEAMLESS INNER GROOVE COPPER		
		DIAMETER	mm/in	7.00 / 0.276		
		THICKNESS	mm/in	0.28 / 0.011		
	FIN	MATERIAL		ALUMINIUM (RAISE LANCE)		
		THICKNESS	mm/in	0.10 / 0.004		
		FACE AREA	m ² /ft ²	0.52 / 5.59		
		ROW		1	2	
FIN PER INCH		20	24			
AIR QUALITY	FILTER	TYPE		WASHABLE SARANET FILTER		
		QUANTITY	pc	1		
		SIZE	LENGTH	mm/in	860 / 33.86	
			WIDTH	mm/in	195 / 7.68	
			THICKNESS	mm/in	5 / 0.20	
CASING	INDOOR UNIT		MATERIAL	GALVANIZED STEEL		
			FINISHING	WITH PE INSULATION		
			COLOUR	WITHOUT POWDER PAINT		
	OUTDOOR UNIT		MATERIAL	GALVANIZED MILD STEEL		
			FINISHING	POLYESTER POWDER		
			COLOUR	LIGHT GREY		

1) ALL SPECIFICATIONS ARE SUBJECTED TO CHANGE BY THE MANUFACTURER WITHOUT PRIOR NOTICE.

Components Data (R22)

MODEL	INDOOR UNIT		MCC 025CR		
	OUTDOOR UNIT		MLC 025CR		
INDOOR FAN	TYPE		CENTRIFUGAL		
	QUANTITY		2		
	MATERIAL		GALVANIZED STEEL		
	DRIVE		DIRECT		
	DIAMETER	mm/in	160 / 6.30		
	LENGTH	mm/in	202 / 7.95		
INDOOR FAN MOTOR	TYPE		INDUCTION		
	QUANTITY		1		
	INDEX OF PROTECTION (IP)		N/A		
OUTDOOR FAN	TYPE		PROPELLER		
	QUANTITY		1		
	MATERIAL		GLASS REINFORCED ACRYL STYRENE RESIN		
	DRIVE		DIRECT		
	DIAMETER	mm/in	457 / 18		
OUTDOOR FAN MOTOR	TYPE		INDUCTION		
	QUANTITY		1		
	INDEX OF PROTECTION (IP)		IP54		
COMPRESSOR	TYPE		ROTARY		
	OIL TYPE		ATMOS M60 or SUNISO 4GDID		
	OIL AMOUNT	cm ³ / fl.oz.	700 / 24.6		
INDOOR COIL	TUBE	MATERIAL		SEAMLESS COPPER	
		DIAMETER	mm/in	9.52 / 3/8	
		THICKNESS	mm/in	0.35 / 0.014	
	FIN	MATERIAL		ALUMINIUM (SLIT FIN)	
		THICKNESS	mm/in	0.11 / 0.0043	
		FACE AREA	m ² /ft ²	0.203 / 2.187	
		ROW		3	
		FIN PER INCH		12	
	OUTDOOR COIL	TUBE	MATERIAL		SEAMLESS INNER GROOVE COPPER
			DIAMETER	mm/in	7.00 / 0.276
THICKNESS			mm/in	0.28 / 0.011	
FIN		MATERIAL		ALUMINIUM (RAISE LANCE)	
		THICKNESS	mm/in	0.10 / 0.004	
		FACE AREA	m ² /ft ²	0.62 / 6.67	
		ROW		2	
		FIN PER INCH		18	
AIR QUALITY		FILTER	TYPE		WASHABLE SARANET FILTER
	QUANTITY		pc	1	
	SIZE	LENGTH	mm/in	995 / 39.17	
		WIDTH	mm/in	195 / 7.68	
		THICKNESS	mm/in	5 / 0.20	
CASING	INDOOR UNIT	MATERIAL	GALVANIZED STEEL		
		FINISHING	WITH PE INSULATION		
		COLOUR	WITHOUT POWDER PAINT		
	OUTDOOR UNIT	MATERIAL	GALVANIZED MILD STEEL		
		FINISHING	POLYESTER POWDER		
		COLOUR	LIGHT GREY		

1) ALL SPECIFICATIONS ARE SUBJECTED TO CHANGE BY THE MANUFACTURER WITHOUT PRIOR NOTICE.

Components Data (R22)

MODEL	INDOOR UNIT		MCC 028CR			
	OUTDOOR UNIT		MLC 028CR	MLC 030CR		
INDOOR FAN	TYPE		CENTRIFUGAL			
	QUANTITY		2			
	MATERIAL		GALVANIZED STEEL			
	DRIVE		DIRECT			
	DIAMETER	mm/in	185 / 7.28			
	LENGTH	mm/in	203 / 7.99			
INDOOR FAN MOTOR	TYPE		INDUCTION			
	QUANTITY		1			
	INDEX OF PROTECTION (IP)		N/A			
OUTDOOR FAN	TYPE		PROPELLER			
	QUANTITY		1			
	MATERIAL		GLASS REINFORCED ACRYL STYRENE RESIN			
	DRIVE		DIRECT			
	DIAMETER	mm/in	457 / 18	609.6 / 24		
OUTDOOR FAN MOTOR	TYPE		INDUCTION			
	QUANTITY		1			
	INDEX OF PROTECTION (IP)		IP54	-		
COMPRESSOR	TYPE		ROTARY	SCROLL		
	OIL TYPE		ATMOS M60 or SUNISO 4GDID	MINERAL (Sontex 200 LT)		
	OIL AMOUNT	cm ³ / fl.oz.	1130 / 39.8	1240 / 43.6		
INDOOR COIL	TUBE	MATERIAL		SEAMLESS COPPER		
		DIAMETER	mm/in	9.52 / 3/8		
		THICKNESS	mm/in	0.36 / 0.014		
	FIN	MATERIAL		ALUMINIUM (CORR. FIN)		
		THICKNESS	mm/in	0.127 / 0.005		
		FACE AREA	m ² /ft ²	0.24 / 2.62		
		ROW		3		
		FIN PER INCH		14		
OUTDOOR COIL	TUBE	MATERIAL		SEAMLESS INNER GROOVE COPPER	SEAMLESS COPPER	
		DIAMETER	mm/in	9.52 / 3/8	9.52 / 3/8	
		THICKNESS	mm/in	0.33 / 0.013	0.35 / 0.014	
	FIN	MATERIAL		ALUMINIUM (SLIT FIN)	ALUMINIUM (SLIT FIN)	
		THICKNESS	mm/in	0.127 / 0.005	0.127 / 0.005	
		FACE AREA	m ² /ft ²	0.61 / 6.52	0.87 / 9.33	
		ROW		2	2	
		FIN PER INCH		18	16	
	AIR QUALITY	FILTER	TYPE		WASHABLE SARANET FILTER	
QUANTITY			pc	2		
SIZE			LENGTH	mm/in	456 / 17.95	
			WIDTH	mm/in	210 / 8.27	
			THICKNESS	mm/in	5 / 0.20	
CASING	INDOOR UNIT	MATERIAL		GALVANIZED STEEL		
		FINISHING		WITH PE INSULATION		
		COLOUR		WITHOUT POWDER PAINT		
	OUTDOOR UNIT	MATERIAL		GALVANIZED MILD STEEL		
		FINISHING		POLYESTER POWDER		
		COLOUR		LIGHT GREY		

1) ALL SPECIFICATIONS ARE SUBJECTED TO CHANGE BY THE MANUFACTURER WITHOUT PRIOR NOTICE.

Components Data (R22)

MODEL	INDOOR UNIT		MCC 038CR		
	OUTDOOR UNIT		MLC 035CR	MLC 040CR	
INDOOR FAN	TYPE		CENTRIFUGAL		
	QUANTITY		2		
	MATERIAL		GALVANIZED STEEL		
	DRIVE		DIRECT		
	DIAMETER	mm/in	214 / 8.43		
	LENGTH	mm/in	203.2 / 8.00		
INDOOR FAN MOTOR	TYPE		INDUCTION		
	QUANTITY		1		
	INDEX OF PROTECTION (IP)		N/A		
OUTDOOR FAN	TYPE		PROPELLER		
	QUANTITY		1		
	MATERIAL		GLASS REINFORCED ACRYL STYRENE RESIN		
	DRIVE		DIRECT		
	DIAMETER	mm/in	609.6 / 24		
OUTDOOR FAN MOTOR	TYPE		INDUCTION		
	QUANTITY		1		
	INDEX OF PROTECTION (IP)		-		
COMPRESSOR	TYPE		SCROLL		
	OIL TYPE		MINERAL (Sontex 200 LT)	MINERAL (Sontex 200 LT)	
	OIL AMOUNT	cm ³ / fl.oz.	1240 / 43.6	1240 / 43.6	
INDOOR COIL	TUBE	MATERIAL		SEAMLESS COPPER	
		DIAMETER	mm/in	9.52 / 3/8	
		THICKNESS	mm/in	0.36 / 0.014	
	FIN	MATERIAL		ALUMINIUM (CORR. FIN)	
		THICKNESS	mm/in	0.127 / 0.005	
		FACE AREA	m ² /ft ²	0.34 / 3.61	
		ROW		3	
		FIN PER INCH		14	
OUTDOOR COIL	TUBE	MATERIAL		SEAMLESS INNER GROOVE COPPER	
		DIAMETER	mm/in	9.52 / 3/8	
		THICKNESS	mm/in	0.33 / 0.013	
	FIN	MATERIAL		ALUMINIUM (CORR. FIN)	
		THICKNESS	mm/in	0.127 / 0.005	
		FACE AREA	m ² /ft ²	0.87 / 9.33	
		ROW		2	
		FIN PER INCH		14	
AIR QUALITY	FILTER	TYPE		WASHABLE SARANET FILTER	
		QUANTITY	pc	2	
		SIZE	LENGTH	mm/in	608 / 23.94
			WIDTH	mm/in	230 / 9.06
			THICKNESS	mm/in	5 / 0.20
		CASING	INDOOR UNIT	MATERIAL	
FINISHING				WITH PE INSULATION	
COLOUR				WITHOUT POWDER PAINT	
OUTDOOR UNIT	MATERIAL		GALVANIZED MILD STEEL		
	FINISHING		POLYESTER POWDER		
	COLOUR		LIGHT GREY		

1) ALL SPECIFICATIONS ARE SUBJECTED TO CHANGE BY THE MANUFACTURER WITHOUT PRIOR NOTICE.

Components Data (R22)

MODEL	INDOOR UNIT			MCC 030CR			
	OUTDOOR UNIT			MLC 028CR		MLC 030CR	
INDOOR FAN	TYPE			CENTRIFUGAL			
	QUANTITY			2			
	MATERIAL			GALVANIZED STEEL			
	DRIVE			DIRECT			
	DIAMETER		mm/in	214 / 8.43			
	LENGTH		mm/in	203.2 / 8.00			
INDOOR FAN MOTOR	TYPE			INDUCTION			
	QUANTITY			1			
	INDEX OF PROTECTION (IP)			N/A			
OUTDOOR FAN	TYPE			PROPELLER			
	QUANTITY			1			
	MATERIAL			GLASS REINFORCED ACRYL STYRENE RESIN			
	DRIVE			DIRECT			
	DIAMETER		mm/in	457 / 18	609.6 / 24		
OUTDOOR FAN MOTOR	TYPE			INDUCTION			
	QUANTITY			1			
	INDEX OF PROTECTION (IP)			IP54	-		
COMPRESSOR	TYPE			ROTARY	SCROLL		
	OIL TYPE			ATMOS M60 or SUNISO 4GDID	MINERAL (Sontex 200 LT)		
	OIL AMOUNT		cm ³ / fl.oz.	1130 / 39.8	1240 / 43.6		
INDOOR COIL	TUBE	MATERIAL			SEAMLESS COPPER		
		DIAMETER		mm/in	9.52 / 3/8		
		THICKNESS		mm/in	0.36 / 0.014		
	FIN	MATERIAL			ALUMINIUM (CORR. FIN)		
		THICKNESS		mm/in	0.127 / 0.005		
		FACE AREA		m ² /ft ²	0.277 / 2.98		
		ROW			3		
		FIN PER INCH			12		
OUTDOOR COIL	TUBE	MATERIAL			SEAMLESS INNER GROOVE COPPER	SEAMLESS COPPER	
		DIAMETER		mm/in	9.52 / 3/8	9.52 / 3/8	
		THICKNESS		mm/in	0.33 / 0.013	0.35 / 0.014	
	FIN	MATERIAL			ALUMINIUM (SLIT FIN)	ALUMINIUM (CORR. FIN)	
		THICKNESS		mm/in	0.127 / 0.005	0.127 / 0.005	
		FACE AREA		m ² /ft ²	0.61 / 6.52	0.87 / 9.33	
		ROW			2	2	
		FIN PER INCH			18	16	
	AIR QUALITY	FILTER	TYPE			WASHABLE SARANET FILTER	
QUANTITY			pc	2			
SIZE			LENGTH		mm/in	449 / 17.68	
			WIDTH		mm/in	305 / 12.01	
			THICKNESS		mm/in	5 / 0.20	
CASING	INDOOR UNIT		MATERIAL		GALVANIZED STEEL		
			FINISHING		WITH PE INSULATION		
			COLOUR		WITHOUT POWDER PAINT		
	OUTDOOR UNIT		MATERIAL		GALVANIZED MILD STEEL		
			FINISHING		POLYESTER POWDER		
			COLOUR		LIGHT GREY		

1) ALL SPECIFICATIONS ARE SUBJECTED TO CHANGE BY THE MANUFACTURER WITHOUT PRIOR NOTICE.

Components Data (R22)

MODEL	INDOOR UNIT		MCC 040CR		
	OUTDOOR UNIT		MLC 035CR	MLC 040CR	
INDOOR FAN	TYPE		CENTRIFUGAL		
	QUANTITY		2		
	MATERIAL		GALVANIZED STEEL		
	DRIVE		DIRECT		
	DIAMETER	mm/in	214 / 8.43		
	LENGTH	mm/in	203.2 / 8.00		
INDOOR FAN MOTOR	TYPE		INDUCTION		
	QUANTITY		1		
	INDEX OF PROTECTION (IP)		N/A		
OUTDOOR FAN	TYPE		PROPELLER		
	QUANTITY		1		
	MATERIAL		GLASS REINFORCED ACRYL STYRENE RESIN		
	DRIVE		DIRECT		
	DIAMETER	mm/in	609.6 / 24		
OUTDOOR FAN MOTOR	TYPE		INDUCTION		
	QUANTITY		1		
	INDEX OF PROTECTION (IP)		-		
COMPRESSOR	TYPE		SCROLL		
	OIL TYPE		MINERAL (Sontex 200 LT)	MINERAL (Sontex 200 LT)	
	OIL AMOUNT	cm ³ / fl.oz.	1240 / 43.6	1240 / 43.6	
INDOOR COIL	TUBE	MATERIAL		SEAMLESS COPPER	
		DIAMETER	mm/in	9.52 / 3/8	
		THICKNESS	mm/in	0.36 / 0.014	
	FIN	MATERIAL		ALUMINIUM (CORR. FIN)	
		THICKNESS	mm/in	0.127 / 0.005	
		FACE AREA	m ² /ft ²	0.31 / 3.44	
		ROW		3	
		FIN PER INCH		14	
OUTDOOR COIL	TUBE	MATERIAL		SEAMLESS INNER GROOVE COPPER	
		DIAMETER	mm/in	9.52 / 3/8	
		THICKNESS	mm/in	0.33 / 0.013	
	FIN	MATERIAL		ALUMINIUM (CORR. FIN)	
		THICKNESS	mm/in	0.127 / 0.005	
		FACE AREA	m ² /ft ²	0.87 / 9.33	
		ROW		2	
		FIN PER INCH		16	
AIR QUALITY	FILTER	TYPE		WASHABLE SARANET FILTER	
		QUANTITY	pc	2	
		SIZE	LENGTH	mm/in	507 / 19.96
			WIDTH	mm/in	305 / 12.01
			THICKNESS	mm/in	5 / 0.20
		CASING	INDOOR UNIT		MATERIAL
FINISHING	WITH PE INSULATION				
COLOUR	WITHOUT POWDER PAINT				
OUTDOOR UNIT			MATERIAL	GALVANIZED MILD STEEL	
			FINISHING	POLYESTER POWDER	
			COLOUR	LIGHT GREY	

1) ALL SPECIFICATIONS ARE SUBJECTED TO CHANGE BY THE MANUFACTURER WITHOUT PRIOR NOTICE.

Components Data (R22)

MODEL	INDOOR UNIT		MCC 050CR	MCC 060CR		
	OUTDOOR UNIT		MLC 050CR	MLC 061CR		
INDOOR FAN	TYPE		CENTRIFUGAL			
	QUANTITY		2			
	MATERIAL		GALVANIZED STEEL			
	DRIVE		DIRECT			
	DIAMETER	mm/in	214 / 8.43			
	LENGTH	mm/in	203.2 / 8.00			
INDOOR FAN MOTOR	TYPE		INDUCTION			
	QUANTITY		1			
	INDEX OF PROTECTION (IP)		N/A			
OUTDOOR FAN	TYPE		PROPELLER			
	QUANTITY		1			
	MATERIAL		GLASS REINFORCED ACRYL STYRENE RESIN			
	DRIVE		DIRECT			
	DIAMETER	mm/in	609.6 / 24			
OUTDOOR FAN MOTOR	TYPE		INDUCTION			
	QUANTITY		1			
	INDEX OF PROTECTION (IP)		-			
COMPRESSOR	TYPE		SCROLL			
	OIL TYPE		MINERAL (Sontex 200 LT)	MINERAL (Sontex 200 LT)		
	OIL AMOUNT	cm ³ / fl.oz.	1950 / 68.6	1705 / 60.0		
INDOOR COIL	TUBE	MATERIAL		SEAMLESS COPPER		
		DIAMETER	mm/in	9.52 / 3/8		
		THICKNESS	mm/in	0.35 / 0.014		
	FIN	MATERIAL		ALUMINIUM (CORR. FIN)	ALUMINIUM (CORR. FIN)	
		THICKNESS	mm/in	0.127 / 0.005	0.127 / 0.005	
		FACE AREA	m ² /ft ²	0.40 / 4.40	0.47 / 5.16	
		ROW		3	3	
		FIN PER INCH		14	14	
	OUTDOOR COIL	TUBE	MATERIAL		SEAMLESS COPPER	SEAMLESS INNER GROOVED COPPER
			DIAMETER	mm/in	9.52 / 3/8	9.52 / 3/8
THICKNESS			mm/in	0.35 / 0.014	0.33 / 0.013	
FIN		MATERIAL		ALUMINIUM (CORR. FIN)	ALUMINIUM (SLIT FIN)	
		THICKNESS	mm/in	0.127 / 0.005	0.127 / 0.005	
		FACE AREA	m ² /ft ²	0.87 / 9.33	0.84 / 9.04	
		ROW		2	3	
		FIN PER INCH		16	14	
AIR QUALITY		FILTER	TYPE		WASHABLE SARANET FILTER	
			QUANTITY		2	
	SIZE		LENGTH	mm/in	634 / 24.96	734 / 28.90
			WIDTH	mm/in	305 / 12.01	305 / 12.01
			THICKNESS	mm/in	5 / 0.20	5 / 0.20
	CASING		INDOOR UNIT	MATERIAL	GALVANIZED STEEL	
FINISHING		WITH PE INSULATION				
COLOUR		WITHOUT POWDER PAINT				
OUTDOOR UNIT		MATERIAL	GALVANIZED MILD STEEL			
		FINISHING	POLYESTER POWDER			
		COLOUR	LIGHT GREY			

1) ALL SPECIFICATIONS ARE SUBJECTED TO CHANGE BY THE MANUFACTURER WITHOUT PRIOR NOTICE.

Components Data (R410A)

MODEL	INDOOR UNIT		M5CC 010C	M5CC 015C		
	OUTDOOR UNIT		M5LC 010C	M5LC 015C		
INDOOR FAN	TYPE		CENTRIFUGAL			
	QUANTITY		1	2		
	MATERIAL		GALVANIZED STEEL			
	DRIVE		DIRECT			
	DIAMETER	mm/in	160 / 6.30			
	LENGTH	mm/in	202 / 7.95			
INDOOR FAN MOTOR	TYPE		INDUCTION			
	QUANTITY		1			
	INDEX OF PROTECTION (IP)		N/A			
OUTDOOR FAN	TYPE		PROPELLER			
	QUANTITY		1			
	MATERIAL		GLASS REINFORCED ACRYL STYRENE RESIN			
	DRIVE		DIRECT			
	DIAMETER	mm/in	404 / 16			
OUTDOOR FAN MOTOR	TYPE		INDUCTION			
	QUANTITY		1			
	INDEX OF PROTECTION (IP)		IP54			
COMPRESSOR	TYPE		ROTARY			
	OIL TYPE		RB68A or Freol Alpha68M			
	OIL AMOUNT	cm ³ / fl.oz.	350 / 12.3	430 / 15.1		
INDOOR COIL	TUBE	MATERIAL		SEAMLESS INNER GROOVE COPPER		
		DIAMETER	mm/in	7.00 / 0.276		
		THICKNESS	mm/in	0.28 / 0.011		
	FIN	MATERIAL		ALUMINIUM (CORR. FIN)	ALUMINIUM (CORR. FIN)	
		THICKNESS	mm/in	0.11 / 0.0043	0.11 / 0.0043	
		FACE AREA	m ² /ft ²	0.115 / 1.238	0.143 / 1.542	
		ROW		3	3	
		FIN PER INCH		18	18	
OUTDOOR COIL	TUBE	MATERIAL		SEAMLESS INNER GROOVE COPPER		
		DIAMETER	mm/in	7.00 / 0.276		
		THICKNESS	mm/in	0.28 / 0.011		
	FIN	MATERIAL		ALUMINIUM (RAISE LANCE)	ALUMINIUM (RAISE LANCE)	
		THICKNESS	mm/in	0.10 / 0.004	0.10 / 0.004	
		FACE AREA	m ² /ft ²	0.360 / 3.94	0.360 / 3.940	
		ROW		1	1	
		FIN PER INCH		18	20	
AIR QUALITY	FILTER	TYPE		WASHABLE SARANET FILTER		
		QUANTITY	pc	1		
		SIZE	LENGTH	mm/in	560 / 22.05	700 / 27.56
			WIDTH	mm/in	195 / 7.68	195 / 7.68
			THICKNESS	mm/in	5 / 0.20	5 / 0.20
		CASING	INDOOR UNIT	MATERIAL		GALVANIZED STEEL
FINISHING				WITH PE INSULATION		
COLOUR				WITHOUT POWDER PAINT		
OUTDOOR UNIT	MATERIAL		GALVANIZED MILD STEEL			
	FINISHING		POLYESTER POWDER			
	COLOUR		LIGHT GREY			

1) ALL SPECIFICATIONS ARE SUBJECTED TO CHANGE BY THE MANUFACTURER WITHOUT PRIOR NOTICE.

Components Data (R410A)

MODEL	INDOOR UNIT		M5CC 020C	M5CC 025C		
	OUTDOOR UNIT		M5LC 020C	M5LC 025C		
INDOOR FAN	TYPE		CENTRIFUGAL			
	QUANTITY		2			
	MATERIAL		GALVANIZED STEEL			
	DRIVE		DIRECT			
	DIAMETER	mm/in	160 / 6.30			
	LENGTH	mm/in	202 / 7.95			
INDOOR FAN MOTOR	TYPE		INDUCTION			
	QUANTITY		1			
	INDEX OF PROTECTION (IP)		N/A			
OUTDOOR FAN	TYPE		PROPELLER			
	QUANTITY		1			
	MATERIAL		GLASS REINFORCED ACRYL STYRENE RESIN			
	DRIVE		DIRECT			
	DIAMETER	mm/in	457 / 18			
OUTDOOR FAN MOTOR	TYPE		INDUCTION			
	QUANTITY		1			
	INDEX OF PROTECTION (IP)		IP54			
COMPRESSOR	TYPE		ROTARY			
	OIL TYPE		RB68A or Freol Alpha68M			
	OIL AMOUNT	cm ³ / fl.oz.	670 / 23.6	1130 / 39.8		
INDOOR COIL	TUBE	MATERIAL		SEAMLESS INNER GROOVE COPPER		
		DIAMETER	mm/in	7.00 / 0.276		
		THICKNESS	mm/in	0.28 / 0.011		
	FIN	MATERIAL		ALUMINIUM (SLIT FIN)	ALUMINIUM (SLIT FIN)	
		THICKNESS	mm/in	0.11 / 0.0043	0.11 / 0.0043	
		FACE AREA	m ² /ft ²	0.176 / 1.892	0.203 / 2.187	
		ROW		3	3	
		FIN PER INCH		18	18	
OUTDOOR COIL	TUBE	MATERIAL		SEAMLESS INNER GROOVE COPPER		
		DIAMETER	mm/in	7.00 / 0.276		
		THICKNESS	mm/in	0.28 / 0.011		
	FIN	MATERIAL		ALUMINIUM (RAISE LANCE)	ALUMINIUM (RAISE LANCE)	
		THICKNESS	mm/in	0.10 / 0.004	0.10 / 0.004	
		FACE AREA	m ² /ft ²	0.510 / 5.460	0.620 / 6.630	
		ROW		2	2	
		FIN PER INCH		18	18	
AIR QUALITY	FILTER	TYPE		WASHABLE SARANET FILTER		
		QUANTITY	pc	1		
		SIZE	LENGTH	mm/in	860 / 33.86	995 / 39.17
			WIDTH	mm/in	195 / 7.68	195 / 7.68
			THICKNESS	mm/in	5 / 0.20	5 / 0.20
CASING	INDOOR UNIT	MATERIAL	GALVANIZED STEEL			
		FINISHING	WITH PE INSULATION			
		COLOUR	WITHOUT POWDER PAINT			
	OUTDOOR UNIT	MATERIAL	GALVANIZED MILD STEEL			
		FINISHING	POLYESTER POWDER			
		COLOUR	LIGHT GREY			

1) ALL SPECIFICATIONS ARE SUBJECTED TO CHANGE BY THE MANUFACTURER WITHOUT PRIOR NOTICE.

Components Data (R410A)

MODEL	INDOOR UNIT		M5CC 028C			
	OUTDOOR UNIT		M5LC 028C	M5LC 035C		
INDOOR FAN	TYPE		CENTRIFUGAL			
	QUANTITY		2			
	MATERIAL		GALVANIZED STEEL			
	DRIVE		DIRECT			
	DIAMETER	mm/in	185 / 7.28			
	LENGTH	mm/in	203 / 7.99			
INDOOR FAN MOTOR	TYPE		INDUCTION			
	QUANTITY		1			
	INDEX OF PROTECTION (IP)		N/A			
OUTDOOR FAN	TYPE		PROPELLER			
	QUANTITY		1			
	MATERIAL		GLASS REINFORCED ACRYL STYRENE RESIN			
	DRIVE		DIRECT			
	DIAMETER	mm/in	457 / 18	609.6 / 24		
OUTDOOR FAN MOTOR	TYPE		INDUCTION			
	QUANTITY		1			
	INDEX OF PROTECTION (IP)		IP54	N/A		
COMPRESSOR	TYPE		ROTARY	SCROLL		
	OIL TYPE		RB68A or Freol Alpha68M	MOBIL EAL ARCTIC 22CC		
	OIL AMOUNT	cm ³ / fl.oz.	1130 / 39.8	1242 / 43.7		
INDOOR COIL	TUBE	MATERIAL		SEAMLESS INNER GROOVE COPPER		
		DIAMETER	mm/in	7.00 / 0.276		
		THICKNESS	mm/in	0.28 / 0.011		
	FIN	MATERIAL		ALUMINIUM (HYDROPHILIC FIN)		
		THICKNESS	mm/in	0.11 / 0.0043		
		FACE AREA	m ² /ft ²	0.24 / 2.62		
		ROW		3		
		FIN PER INCH		18		
OUTDOOR COIL	TUBE	MATERIAL		SEAMLESS INNER GROOVE COPPER		
		DIAMETER	mm/in	7.00 / 0.276		
		THICKNESS	mm/in	0.28 / 0.011		
	FIN	MATERIAL		ALUMINIUM (CORR. FIN)	ALUMINIUM (CORR. FIN)	
		THICKNESS	mm/in	0.11 / 0.0043	0.11 / 0.0043	
		FACE AREA	m ² /ft ²	0.620 / 6.630	0.870 / 9.330	
		ROW		2	2	
		FIN PER INCH		18	18	
AIR QUALITY	FILTER	TYPE		WASHABLE SARANET FILTER		
		QUANTITY	pc	2		
		SIZE	LENGTH	mm/in	456 / 17.95	
			WIDTH	mm/in	210 / 8.27	
			THICKNESS	mm/in	5 / 0.20	
CASING	INDOOR UNIT	MATERIAL	GALVANIZED STEEL			
		FINISHING	WITH PE INSULATION			
		COLOUR	WITHOUT POWDER PAINT			
	OUTDOOR UNIT	MATERIAL	GALVANIZED MILD STEEL			
		FINISHING	POLYESTER POWDER			
		COLOUR	LIGHT GREY			

1) ALL SPECIFICATIONS ARE SUBJECTED TO CHANGE BY THE MANUFACTURER WITHOUT PRIOR NOTICE.

Components Data (R410A)

MODEL	INDOOR UNIT		M5CC 038C		
	OUTDOOR UNIT		M5LC 040C		
INDOOR FAN	TYPE		CENTRIFUGAL		
	QUANTITY		2		
	MATERIAL		GALVANIZED STEEL		
	DRIVE		DIRECT		
	DIAMETER	mm/in	214 / 8.43		
	LENGTH	mm/in	203.2 / 8.00		
INDOOR FAN MOTOR	TYPE		INDUCTION		
	QUANTITY		1		
	INDEX OF PROTECTION (IP)		N/A		
OUTDOOR FAN	TYPE		PROPELLER		
	QUANTITY		1		
	MATERIAL		GLASS REINFORCED ACRYL STYRENE RESIN		
	DRIVE		DIRECT		
	DIAMETER	mm/in	609.6 / 24		
OUTDOOR FAN MOTOR	TYPE		INDUCTION		
	QUANTITY		1		
	INDEX OF PROTECTION (IP)		-		
COMPRESSOR	TYPE		SCROLL		
	OIL TYPE		MOBIL EAL ARCTIC 22CC		
	OIL AMOUNT	cm ³ / fl.oz.	1951 / 68.7		
INDOOR COIL	TUBE	MATERIAL		SEAMLESS INNER GROOVE COPPER	
		DIAMETER	mm/in	7.00 / 0.276	
		THICKNESS	mm/in	0.28 / 0.011	
	FIN	MATERIAL		ALUMINIUM (HYDROPHILIC FIN)	
		THICKNESS	mm/in	0.11 / 0.0043	
		FACE AREA	m ² /ft ²	0.34 / 3.61	
		ROW		3	
		FIN PER INCH		18	
OUTDOOR COIL	TUBE	MATERIAL		SEAMLESS INNER GROOVE COPPER	
		DIAMETER	mm/in	7.00 / 0.276	
		THICKNESS	mm/in	0.28 / 0.011	
	FIN	MATERIAL		ALUMINIUM (CORR. FIN)	
		THICKNESS	mm/in	0.10 / 0.0039	
		FACE AREA	m ² /ft ²	0.87 / 9.33	
		ROW		2	
		FIN PER INCH		18	
AIR QUALITY	FILTER	TYPE		WASHABLE SARANET FILTER	
		QUANTITY	pc	2	
		SIZE	LENGTH	mm/in	608 / 23.94
			WIDTH	mm/in	230 / 9.06
			THICKNESS	mm/in	5 / 0.20
		CASING	INDOOR UNIT	MATERIAL	GALVANIZED STEEL
FINISHING	WITH PE INSULATION				
COLOUR	WITHOUT POWDER PAINT				
OUTDOOR UNIT	MATERIAL		GALVANIZED MILD STEEL		
	FINISHING		POLYESTER POWDER		
	COLOUR		LIGHT GREY		

1) ALL SPECIFICATIONS ARE SUBJECTED TO CHANGE BY THE MANUFACTURER WITHOUT PRIOR NOTICE.

Components Data (R410A)

MODEL	INDOOR UNIT		M5CC 050C	M5CC 060C		
	OUTDOOR UNIT		M5LC 050C	M5LC 061C		
INDOOR FAN	TYPE		CENTRIFUGAL			
	QUANTITY		2			
	MATERIAL		GALVANIZED STEEL			
	DRIVE		DIRECT			
	DIAMETER	mm/in	214 / 8.43			
	LENGTH	mm/in	203.2 / 8.00			
INDOOR FAN MOTOR	TYPE		INDUCTION			
	QUANTITY		1			
	INDEX OF PROTECTION (IP)		N/A			
OUTDOOR FAN	TYPE		PROPELLER			
	QUANTITY		1			
	MATERIAL		GLASS REINFORCED ACRYL STYRENE RESIN			
	DRIVE		DIRECT			
	DIAMETER	mm/in	609.6 / 24			
OUTDOOR FAN MOTOR	TYPE		INDUCTION			
	QUANTITY		1			
	INDEX OF PROTECTION (IP)		-			
COMPRESSOR	TYPE		SCROLL			
	OIL TYPE		MOBIL EAL ARCTIC 22CC	MOBIL EAL ARCTIC 22CC		
	OIL AMOUNT	cm ³ / fl.oz.	1656 / 58.3	1591 / 56		
INDOOR COIL	TUBE	MATERIAL		SEAMLESS INNER GROOVE COPPER		
		DIAMETER	mm/in	7.00 / 0.276		
		THICKNESS	mm/in	0.28 / 0.011		
	FIN	MATERIAL		ALUMINIUM (HYDROPHILIC FIN)	ALUMINIUM (HYDROPHILIC FIN)	
		THICKNESS	mm/in	0.11 / 0.0043	0.11 / 0.0043	
		FACE AREA	m ² /ft ²	0.40 / 4.40	0.47 / 5.16	
		ROW		3	3	
		FIN PER INCH		18	20	
OUTDOOR COIL	TUBE	MATERIAL		SEAMLESS COPPER		
		DIAMETER	mm/in	7.00 / 0.276		
		THICKNESS	mm/in	0.28 / 0.011		
	FIN	MATERIAL		ALUMINIUM (CORR. FIN)	ALUMINIUM (CORR. FIN)	
		THICKNESS	mm/in	0.10 / 0.0039	0.10 / 0.0039	
		FACE AREA	m ² /ft ²	0.87 / 9.33	0.84 / 9.04	
		ROW		2	3	
		FIN PER INCH		18	18	
AIR QUALITY	FILTER	TYPE		WASHABLE SARANET FILTER		
		QUANTITY		2		
		SIZE	LENGTH	mm/in	634 / 24.96	734 / 28.90
			WIDTH	mm/in	305 / 12.01	305 / 12.01
			THICKNESS	mm/in	5 / 0.20	5 / 0.20
CASING	INDOOR UNIT	MATERIAL	GALVANIZED STEEL			
		FINISHING	WITH PE INSULATION			
		COLOUR	WITHOUT POWDER PAINT			
	OUTDOOR UNIT	MATERIAL	GALVANIZED MILD STEEL			
		FINISHING	POLYESTER POWDER			
		COLOUR	LIGHT GREY			

1) ALL SPECIFICATIONS ARE SUBJECTED TO CHANGE BY THE MANUFACTURER WITHOUT PRIOR NOTICE.

Components Data (R410A)

MODEL	INDOOR UNIT		M5CC 010CR	M5CC 015CR		
	OUTDOOR UNIT		M5LC 010CR	M5LC 015CR		
INDOOR FAN	TYPE		CENTRIFUGAL			
	QUANTITY		1	2		
	MATERIAL		GALVANIZED STEEL			
	DRIVE		DIRECT			
	DIAMETER	mm/in	160 / 6.30			
	LENGTH	mm/in	202 / 7.95			
INDOOR FAN MOTOR	TYPE		INDUCTION			
	QUANTITY		1			
	INDEX OF PROTECTION (IP)		N/A			
OUTDOOR FAN	TYPE		PROPELLER			
	QUANTITY		1			
	MATERIAL		GLASS REINFORCED ACRYL STYRENE RESIN			
	DRIVE		DIRECT			
	DIAMETER	mm/in	404 / 16			
OUTDOOR FAN MOTOR	TYPE		INDUCTION			
	QUANTITY		1			
	INDEX OF PROTECTION (IP)		IP54			
COMPRESSOR	TYPE		ROTARY			
	OIL TYPE		RB68A or Freol Alpha68M			
	OIL AMOUNT	cm ³ / fl.oz.	350 / 12.3	430 / 15.1		
INDOOR COIL	TUBE	MATERIAL		SEAMLESS INNER GROOVE COPPER		
		DIAMETER	mm/in	7.00 / 0.276		
		THICKNESS	mm/in	0.28 / 0.011		
	FIN	MATERIAL		ALUMINIUM (CORR. FIN)	ALUMINIUM (CORR. FIN)	
		THICKNESS	mm/in	0.11 / 0.0043	0.11 / 0.0043	
		FACE AREA	m ² /ft ²	0.115 / 1.238	0.143 / 1.542	
		ROW		3	3	
		FIN PER INCH		18	18	
OUTDOOR COIL	TUBE	MATERIAL		SEAMLESS INNER GROOVE COPPER		
		DIAMETER	mm/in	9.52 / 3/8		
		THICKNESS	mm/in	0.33 / 0.013		
	FIN	MATERIAL		ALUMINIUM (SLIT FIN)		
		THICKNESS	mm/in	0.127 / 0.005		
		FACE AREA	m ² /ft ²	0.360 / 3.940		
		ROW		1		
		FIN PER INCH		18		
AIR QUALITY	FILTER	TYPE		WASHABLE SARANET FILTER		
		QUANTITY	pc	1		
		SIZE	LENGTH	mm/in	560 / 22.05	
			WIDTH	mm/in	195 / 7.68	
			THICKNESS	mm/in	5 / 0.20	
		CASING	INDOOR UNIT	MATERIAL		GALVANIZED STEEL
FINISHING				WITH PE INSULATION		
COLOUR				WITHOUT POWDER PAINT		
OUTDOOR UNIT	MATERIAL		GALVANIZED MILD STEEL			
	FINISHING		POLYESTER POWDER			
	COLOUR		LIGHT GREY			

1) ALL SPECIFICATIONS ARE SUBJECTED TO CHANGE BY THE MANUFACTURER WITHOUT PRIOR NOTICE.

Components Data (R410A)

MODEL	INDOOR UNIT		M5CC 020CR	M5CC 025CR		
	OUTDOOR UNIT		M5LC 020CR	M5LC 025CR		
INDOOR FAN	TYPE		CENTRIFUGAL			
	QUANTITY		2			
	MATERIAL		GALVANIZED STEEL			
	DRIVE		DIRECT			
	DIAMETER	mm/in	160 / 6.30			
	LENGTH	mm/in	202 / 7.95			
INDOOR FAN MOTOR	TYPE		INDUCTION			
	QUANTITY		1			
	INDEX OF PROTECTION (IP)		N/A			
OUTDOOR FAN	TYPE		PROPELLER			
	QUANTITY		1			
	MATERIAL		GLASS REINFORCED ACRYL STYRENE RESIN			
	DRIVE		DIRECT			
	DIAMETER	mm/in	457 / 18			
OUTDOOR FAN MOTOR	TYPE		INDUCTION			
	QUANTITY		1			
	INDEX OF PROTECTION (IP)		IP54			
COMPRESSOR	TYPE		ROTARY			
	OIL TYPE		RB68A or Freol Alpha68M			
	OIL AMOUNT	cm ³ / fl.oz.	670 / 23.6	1130 / 39.8		
INDOOR COIL	TUBE	MATERIAL		SEAMLESS INNER GROOVE COPPER		
		DIAMETER	mm/in	7.00 / 0.276		
		THICKNESS	mm/in	0.28 / 0.011		
	FIN	MATERIAL		ALUMINIUM (SLIT FIN)	ALUMINIUM (SLIT FIN)	
		THICKNESS	mm/in	0.11 / 0.0043	0.11 / 0.0043	
		FACE AREA	m ² /ft ²	0.176 / 1.892	0.203 / 2.187	
		ROW		3	3	
		FIN PER INCH		18	18	
OUTDOOR COIL	TUBE	MATERIAL		SEAMLESS INNER GROOVE COPPER		
		DIAMETER	mm/in	7.00 / 0.276		
		THICKNESS	mm/in	0.28 / 0.011		
	FIN	MATERIAL		ALUMINIUM (CORR. FIN)	ALUMINIUM (CORR. FIN)	
		THICKNESS	mm/in	0.11 / 0.0043	0.11 / 0.0043	
		FACE AREA	m ² /ft ²	0.510 / 5.460	0.620 / 6.630	
		ROW		2	2	
		FIN PER INCH		18	18	
AIR QUALITY	FILTER	TYPE		WASHABLE SARANET FILTER		
		QUANTITY	pc	1		
		SIZE	LENGTH	mm/in	860 / 33.86	995 / 39.17
			WIDTH	mm/in	195 / 7.68	195 / 7.68
			THICKNESS	mm/in	5 / 0.20	5 / 0.20
CASING	INDOOR UNIT	MATERIAL	GALVANIZED STEEL			
		FINISHING	WITH PE INSULATION			
		COLOUR	WITHOUT POWDER PAINT			
	OUTDOOR UNIT	MATERIAL	GALVANIZED MILD STEEL			
		FINISHING	POLYESTER POWDER			
		COLOUR	LIGHT GREY			

1) ALL SPECIFICATIONS ARE SUBJECTED TO CHANGE BY THE MANUFACTURER WITHOUT PRIOR NOTICE.

Components Data (R410A)

MODEL	INDOOR UNIT			M5CC 028CR			
	OUTDOOR UNIT			M5LC 028CR		M5LC 035CR	
INDOOR FAN	TYPE			CENTRIFUGAL			
	QUANTITY			2			
	MATERIAL			GALVANIZED STEEL			
	DRIVE			DIRECT			
	DIAMETER		mm/in	185 / 7.28			
	LENGTH		mm/in	203 / 7.99			
INDOOR FAN MOTOR	TYPE			INDUCTION			
	QUANTITY			1			
	INDEX OF PROTECTION (IP)			N/A			
OUTDOOR FAN	TYPE			PROPELLER			
	QUANTITY			1			
	MATERIAL			GLASS REINFORCED ACRYL STYRENE RESIN			
	DRIVE			DIRECT			
	DIAMETER		mm/in	457 / 18	609.6 / 24		
OUTDOOR FAN MOTOR	TYPE			INDUCTION			
	QUANTITY			1			
	INDEX OF PROTECTION (IP)			IP54	N/A		
COMPRESSOR	TYPE			ROTARY	SCROLL		
	OIL TYPE			RB68A or Freol Alpha68M	MOBIL EAL ARCTIC 22CC		
	OIL AMOUNT		cm ³ / fl.oz.	1130 / 39.8	1242 / 43.7		
INDOOR COIL	TUBE	MATERIAL			SEAMLESS INNER GROOVE COPPER		
		DIAMETER		mm/in	7.00 / 0.276		
		THICKNESS		mm/in	0.28 / 0.011		
	FIN	MATERIAL			ALUMINIUM (HYDROPHILIC FIN)		
		THICKNESS		mm/in	0.11 / 0.0043		
		FACE AREA		m ² /ft ²	0.240 / 2.620		
		ROW			3		
		FIN PER INCH			18		
OUTDOOR COIL	TUBE	MATERIAL			SEAMLESS INNER GROOVE COPPER		
		DIAMETER		mm/in	7.00 / 0.276		
		THICKNESS		mm/in	0.28 / 0.011		
	FIN	MATERIAL			ALUMINIUM (CORR. FIN)	ALUMINIUM (CORR. FIN)	
		THICKNESS		mm/in	0.11 / 0.0043	0.11 / 0.0043	
		FACE AREA		m ² /ft ²	0.620 / 6.630	0.870 / 9.330	
		ROW			2		
		FIN PER INCH			18		
AIR QUALITY	FILTER	TYPE			WASHABLE SARANET FILTER		
		QUANTITY		pc	2		
		SIZE	LENGTH		mm/in	456 / 17.95	
			WIDTH		mm/in	210 / 8.27	
			THICKNESS		mm/in	5 / 0.20	
		CASING	INDOOR UNIT	MATERIAL			GALVANIZED STEEL
FINISHING				WITH PE INSULATION			
COLOUR				WITHOUT POWDER PAINT			
OUTDOOR UNIT	MATERIAL			GALVANIZED MILD STEEL			
	FINISHING			POLYESTER POWDER			
	COLOUR			LIGHT GREY			

1) ALL SPECIFICATIONS ARE SUBJECTED TO CHANGE BY THE MANUFACTURER WITHOUT PRIOR NOTICE.

Components Data (R410A)

MODEL	INDOOR UNIT		M5CC 038CR		
	OUTDOOR UNIT		M5LC 040CR		
INDOOR FAN	TYPE		CENTRIFUGAL		
	QUANTITY		2		
	MATERIAL		GALVANIZED STEEL		
	DRIVE		DIRECT		
	DIAMETER	mm/in	214 / 8.43		
	LENGTH	mm/in	203.2 / 8.00		
INDOOR FAN MOTOR	TYPE		INDUCTION		
	QUANTITY		1		
	INDEX OF PROTECTION (IP)		N/A		
OUTDOOR FAN	TYPE		PROPELLER		
	QUANTITY		1		
	MATERIAL		GLASS REINFORCED ACRYL STYRENE RESIN		
	DRIVE		DIRECT		
	DIAMETER	mm/in	609.6 / 24		
OUTDOOR FAN MOTOR	TYPE		INDUCTION		
	QUANTITY		1		
	INDEX OF PROTECTION (IP)		-		
COMPRESSOR	TYPE		SCROLL		
	OIL TYPE		MOBIL EAL ARCTIC 22CC		
	OIL AMOUNT	cm ³ / fl.oz.	1951 / 68.7		
INDOOR COIL	TUBE	MATERIAL		SEAMLESS INNER GROOVE COPPER	
		DIAMETER	mm/in	7.00 / 0.276	
		THICKNESS	mm/in	0.28 / 0.011	
	FIN	MATERIAL		ALUMINIUM (HYDROPHILIC FIN)	
		THICKNESS	mm/in	0.11 / 0.0043	
		FACE AREA	m ² /ft ²	0.34 / 3.61	
		ROW		3	
		FIN PER INCH		18	
	OUTDOOR COIL	TUBE	MATERIAL		SEAMLESS INNER GROOVE COPPER
			DIAMETER	mm/in	7.00 / 0.276
THICKNESS			mm/in	0.28 / 0.011	
FIN		MATERIAL		ALUMINIUM (CORR. FIN)	
		THICKNESS	mm/in	0.10 / 0.0039	
		FACE AREA	m ² /ft ²	0.87 / 9.33	
		ROW		2	
		FIN PER INCH		18	
AIR QUALITY		FILTER	TYPE		WASHABLE SARANET FILTER
			QUANTITY	pc	2
	SIZE	LENGTH	mm/in	608 / 23.94	
		WIDTH	mm/in	230 / 9.06	
		THICKNESS	mm/in	5 / 0.20	
	CASING	INDOOR UNIT	MATERIAL	GALVANIZED STEEL	
FINISHING			WITH PE INSULATION		
COLOUR			WITHOUT POWDER PAINT		
OUTDOOR UNIT		MATERIAL	GALVANIZED MILD STEEL		
		FINISHING	POLYESTER POWDER		
		COLOUR	LIGHT GREY		

1) ALL SPECIFICATIONS ARE SUBJECTED TO CHANGE BY THE MANUFACTURER WITHOUT PRIOR NOTICE.

Components Data (R410A)

MODEL	INDOOR UNIT		M5CC 050CR	M5CC 060CR		
	OUTDOOR UNIT		M5LC 050CR	M5LC 061CR		
INDOOR FAN	TYPE		CENTRIFUGAL			
	QUANTITY		2			
	MATERIAL		GALVANIZED STEEL			
	DRIVE		DIRECT			
	DIAMETER	mm/in	214 / 8.43			
	LENGTH	mm/in	203.2 / 8.00			
INDOOR FAN MOTOR	TYPE		INDUCTION			
	QUANTITY		1			
	INDEX OF PROTECTION (IP)		N/A			
OUTDOOR FAN	TYPE		PROPELLER			
	QUANTITY		1			
	MATERIAL		GLASS REINFORCED ACRYL STYRENE RESIN			
	DRIVE		DIRECT			
	DIAMETER	mm/in	609.6 / 24			
OUTDOOR FAN MOTOR	TYPE		INDUCTION			
	QUANTITY		1			
	INDEX OF PROTECTION (IP)		-			
COMPRESSOR	TYPE		SCROLL			
	OIL TYPE		MOBIL EAL ARCTIC 22CC	MOBIL EAL ARCTIC 22CC		
	OIL AMOUNT	cm ³ / fl.oz.	1656 / 58.3	1591 / 56		
INDOOR COIL	TUBE	MATERIAL		SEAMLESS INNER GROOVE COPPER		
		DIAMETER	mm/in	7.00 / 0.276		
		THICKNESS	mm/in	0.28 / 0.011		
	FIN	MATERIAL		ALUMINIUM (HYDROPHILIC FIN)	ALUMINIUM (HYDROPHILIC FIN)	
		THICKNESS	mm/in	0.11 / 0.0043	0.11 / 0.0043	
		FACE AREA	m ² /ft ²	0.40 / 4.40	0.47 / 5.16	
		ROW		3	3	
		FIN PER INCH		18	20	
OUTDOOR COIL	TUBE	MATERIAL		SEAMLESS COPPER		
		DIAMETER	mm/in	7.00 / 0.276		
		THICKNESS	mm/in	0.28 / 0.011		
	FIN	MATERIAL		ALUMINIUM (CORR. FIN)	ALUMINIUM (CORR. FIN)	
		THICKNESS	mm/in	0.10 / 0.0039	0.10 / 0.0039	
		FACE AREA	m ² /ft ²	0.87 / 9.33	0.84 / 9.04	
		ROW		2	3	
		FIN PER INCH		18	18	
AIR QUALITY	FILTER	TYPE		WASHABLE SARANET FILTER		
		QUANTITY	pc	2		
		SIZE	LENGTH	mm/in	634 / 24.96	734 / 28.90
			WIDTH	mm/in	305 / 12.01	305 / 12.01
			THICKNESS	mm/in	5 / 0.20	5 / 0.20
CASING	INDOOR UNIT		MATERIAL	GALVANIZED STEEL		
			FINISHING	WITH PE INSULATION		
			COLOUR	WITHOUT POWDER PAINT		
	OUTDOOR UNIT		MATERIAL	GALVANIZED MILD STEEL		
			FINISHING	POLYESTER POWDER		
			COLOUR	LIGHT GREY		

1) ALL SPECIFICATIONS ARE SUBJECTED TO CHANGE BY THE MANUFACTURER WITHOUT PRIOR NOTICE.

Safety Devices

MODEL	INDOOR UNIT		MCC 010C	MCC 015C
	OUTDOOR UNIT		MLC 010C	MLC 015C
SAFETY DEVICE	HIGH PRESSURE SWITCH	TYPE	N/A	N/A
		OPEN	kPa / psi	N/A
		CLOSE	kPa / psi	N/A
	LOW PRESSURE SWITCH	TYPE	N/A	N/A
		OPEN	kPa / psi	N/A
		CLOSE	kPa / psi	N/A
	PHASE SEQUENCER		N/A	N/A
	DISCHARGE THERMOSTAT SETTING		°C / °F	N/A

MODEL	INDOOR UNIT		MCC 020C	
	OUTDOOR UNIT		MLC 018C	MLC 020C
SAFETY DEVICE	HIGH PRESSURE SWITCH	TYPE	N/A	N/A
		OPEN	kPa / psi	N/A
		CLOSE	kPa / psi	N/A
	LOW PRESSURE SWITCH	TYPE	N/A	N/A
		OPEN	kPa / psi	N/A
		CLOSE	kPa / psi	N/A
	PHASE SEQUENCER		N/A	N/A
	DISCHARGE THERMOSTAT SETTING		°C / °F	N/A

MODEL	INDOOR UNIT		MCC 025C
	OUTDOOR UNIT		MLC 025C
SAFETY DEVICE	HIGH PRESSURE SWITCH	TYPE	N/A
		OPEN	kPa / psi
		CLOSE	kPa / psi
	LOW PRESSURE SWITCH	TYPE	N/A
		OPEN	kPa / psi
		CLOSE	kPa / psi
	PHASE SEQUENCER		N/A
	DISCHARGE THERMOSTAT SETTING		°C / °F

MODEL	INDOOR UNIT		MCC 028C	
	OUTDOOR UNIT		MLC 028C	MLC 030C
SAFETY DEVICE	HIGH PRESSURE SWITCH	TYPE	N/A	NC
		OPEN	kPa / psi	2937 / 426
		CLOSE	kPa / psi	2413 / 350
	LOW PRESSURE SWITCH	TYPE	N/A	NC
		OPEN	kPa / psi	124 / 18
		CLOSE	kPa / psi	193 / 28
	PHASE SEQUENCER - 1Ø / <3Ø>		N/A	N/A / <YES>
	DISCHARGE THERMOSTAT SETTING - 1Ø / <3Ø>		°C / °F	N/A / <130 / 266>

1) ALL SPECIFICATIONS ARE SUBJECTED TO CHANGE BY THE MANUFACTURER WITHOUT PRIOR NOTICE.

Safety Devices

MODEL	INDOOR UNIT		MCC 038C		
	OUTDOOR UNIT		MLC 035C	MLC 040C	
SAFETY DEVICE	HIGH PRESSURE SWITCH	TYPE		N/A	NC
		OPEN	kPa / psi	N/A	2937 / 426
		CLOSE	kPa / psi	N/A	2413 / 350
	LOW PRESSURE SWITCH	TYPE		N/A	NC
		OPEN	kPa / psi	N/A	124 / 18
		CLOSE	kPa / psi	N/A	193 / 28
	PHASE SEQUENCER - 1Ø / <3Ø>		N/A		N/A / <YES>
	DISCHARGE THERMOSTAT SETTING - 1Ø / <3Ø>		°C / °F	N/A	N/A / <130 / 266>

MODEL	INDOOR UNIT		MCC 030C		
	OUTDOOR UNIT		MLC 028C	MLC 030C	
SAFETY DEVICE	HIGH PRESSURE SWITCH	TYPE		N/A	NC
		OPEN	kPa / psi	N/A	2937 / 426
		CLOSE	kPa / psi	N/A	2413 / 350
	LOW PRESSURE SWITCH	TYPE		N/A	NC
		OPEN	kPa / psi	N/A	124 / 18
		CLOSE	kPa / psi	N/A	193 / 28
	PHASE SEQUENCER - 1Ø / <3Ø>		N/A		N/A / <YES>
	DISCHARGE THERMOSTAT SETTING - 1Ø / <3Ø>		°C / °F	N/A	N/A / <130 / 266>

MODEL	INDOOR UNIT		MCC 040C		
	OUTDOOR UNIT		MLC 035C	MLC 040C	
SAFETY DEVICE	HIGH PRESSURE SWITCH	TYPE		N/A	NC
		OPEN	kPa / psi	N/A	2937 / 426
		CLOSE	kPa / psi	N/A	2413 / 350
	LOW PRESSURE SWITCH	TYPE		N/A	NC
		OPEN	kPa / psi	N/A	124 / 18
		CLOSE	kPa / psi	N/A	193 / 28
	PHASE SEQUENCER - 1Ø / <3Ø>		N/A		N/A / <YES>
	DISCHARGE THERMOSTAT SETTING - 1Ø / <3Ø>		°C / °F	N/A	N/A / <130 / 266>

MODEL	INDOOR UNIT		MCC 050C	MCC 060C
	OUTDOOR UNIT		MLC 050C	MLC 061C
SAFETY DEVICE	HIGH PRESSURE SWITCH	TYPE		NC
		OPEN	kPa / psi	2937 / 426
		CLOSE	kPa / psi	2413 / 350
	LOW PRESSURE SWITCH	TYPE		NC
		OPEN	kPa / psi	124 / 18
		CLOSE	kPa / psi	193 / 28
	PHASE SEQUENCER		YES	
	DISCHARGE THERMOSTAT SETTING		130 / 266	
		°C / °F		

1) ALL SPECIFICATIONS ARE SUBJECTED TO CHANGE BY THE MANUFACTURER WITHOUT PRIOR NOTICE.

Safety Devices

MODEL	INDOOR UNIT		MCC 010CR	MCC 015CR
	OUTDOOR UNIT		MLC 010CR	MLC 015CR
SAFETY DEVICE	HIGH PRESSURE SWITCH	TYPE	N/A	N/A
		OPEN	kPa / psi	N/A
		CLOSE	kPa / psi	N/A
	LOW PRESSURE SWITCH	TYPE	N/A	N/A
		OPEN	kPa / psi	N/A
		CLOSE	kPa / psi	N/A
	PHASE SEQUENCER		N/A	N/A
	DISCHARGE THERMOSTAT SETTING		°C / °F	N/A

MODEL	INDOOR UNIT		MCC 020CR	
	OUTDOOR UNIT		MLC 018CR	MLC 020CR
SAFETY DEVICE	HIGH PRESSURE SWITCH	TYPE	N/A	N/A
		OPEN	kPa / psi	N/A
		CLOSE	kPa / psi	N/A
	LOW PRESSURE SWITCH	TYPE	N/A	N/A
		OPEN	kPa / psi	N/A
		CLOSE	kPa / psi	N/A
	PHASE SEQUENCER		N/A	N/A
	DISCHARGE THERMOSTAT SETTING		°C / °F	N/A

MODEL	INDOOR UNIT		MCC 025CR
	OUTDOOR UNIT		MLC 025CR
SAFETY DEVICE	HIGH PRESSURE SWITCH	TYPE	N/A
		OPEN	kPa / psi
		CLOSE	kPa / psi
	LOW PRESSURE SWITCH	TYPE	N/A
		OPEN	kPa / psi
		CLOSE	kPa / psi
	PHASE SEQUENCER		N/A
	DISCHARGE THERMOSTAT SETTING		°C / °F

MODEL	INDOOR UNIT		MCC 028CR	
	OUTDOOR UNIT		MLC 028CR	MLC 030CR
SAFETY DEVICE	HIGH PRESSURE SWITCH	TYPE	N/A	NC
		OPEN	kPa / psi	2937 / 426
		CLOSE	kPa / psi	2413 / 350
	LOW PRESSURE SWITCH	TYPE	N/A	N/A
		OPEN	kPa / psi	N/A
		CLOSE	kPa / psi	N/A
	PHASE SEQUENCER - 1Ø / <3Ø>		N/A	N/A / <YES>
	DISCHARGE THERMOSTAT SETTING - 1Ø / <3Ø>		°C / °F	N/A / <130 / 266>

1) ALL SPECIFICATIONS ARE SUBJECTED TO CHANGE BY THE MANUFACTURER WITHOUT PRIOR NOTICE.

Safety Devices

MODEL	INDOOR UNIT		MCC 038CR		
	OUTDOOR UNIT		MLC 035CR	MLC 040CR	
SAFETY DEVICE	HIGH PRESSURE SWITCH	TYPE		N/A	NC
		OPEN	kPa / psi	N/A	2937 / 426
		CLOSE	kPa / psi	N/A	2413 / 350
	LOW PRESSURE SWITCH	TYPE		N/A	N/A
		OPEN	kPa / psi	N/A	N/A
		CLOSE	kPa / psi	N/A	N/A
	PHASE SEQUENCER - 1Ø / <3Ø>			N/A	N/A / <YES>
	DISCHARGE THERMOSTAT SETTING - 1Ø / <3Ø>			°C / °F	N/A / <130 / 266>

MODEL	INDOOR UNIT		MCC 030CR		
	OUTDOOR UNIT		MLC 028CR	MLC 030CR	
SAFETY DEVICE	HIGH PRESSURE SWITCH	TYPE		N/A	NC
		OPEN	kPa / psi	N/A	2937 / 426
		CLOSE	kPa / psi	N/A	2413 / 350
	LOW PRESSURE SWITCH	TYPE		N/A	N/A
		OPEN	kPa / psi	N/A	N/A
		CLOSE	kPa / psi	N/A	N/A
	PHASE SEQUENCER - 1Ø / <3Ø>			N/A	N/A / <YES>
	DISCHARGE THERMOSTAT SETTING - 1Ø / <3Ø>			°C / °F	N/A / <130 / 266>

MODEL	INDOOR UNIT		MCC 040CR		
	OUTDOOR UNIT		MLC 035CR	MLC 040CR	
SAFETY DEVICE	HIGH PRESSURE SWITCH	TYPE		N/A	NC
		OPEN	kPa / psi	N/A	2937 / 426
		CLOSE	kPa / psi	N/A	2413 / 350
	LOW PRESSURE SWITCH	TYPE		N/A	N/A
		OPEN	kPa / psi	N/A	N/A
		CLOSE	kPa / psi	N/A	N/A
	PHASE SEQUENCER - 1Ø / <3Ø>			N/A	N/A / <YES>
	DISCHARGE THERMOSTAT SETTING - 1Ø / <3Ø>			°C / °F	N/A / <130 / 266>

MODEL	INDOOR UNIT		MCC 050CR	MCC 060CR
	OUTDOOR UNIT		MLC 050CR	MLC 061CR
SAFETY DEVICE	HIGH PRESSURE SWITCH	TYPE		NC
		OPEN	kPa / psi	2937 / 426
		CLOSE	kPa / psi	2413 / 350
	LOW PRESSURE SWITCH	TYPE		N/A
		OPEN	kPa / psi	N/A
		CLOSE	kPa / psi	N/A
	PHASE SEQUENCER			YES
	DISCHARGE THERMOSTAT SETTING			°C / °F

1) ALL SPECIFICATIONS ARE SUBJECTED TO CHANGE BY THE MANUFACTURER WITHOUT PRIOR NOTICE.

Safety Devices

MODEL	INDOOR UNIT		M5CC 010C	M5CC 015C
	OUTDOOR UNIT		M5LC 010C	M5LC 015C
SAFETY DEVICE	HIGH PRESSURE SWITCH	TYPE	N/A	N/A
		OPEN	kPa / psi	N/A
		CLOSE	kPa / psi	N/A
	LOW PRESSURE SWITCH	TYPE	N/A	N/A
		OPEN	kPa / psi	N/A
		CLOSE	kPa / psi	N/A
	PHASE SEQUENCER		N/A	N/A
	DISCHARGE THERMOSTAT SETTING		°C / °F	N/A

MODEL	INDOOR UNIT		M5CC 020C	M5CC 025C
	OUTDOOR UNIT		M5LC 020C	M5LC 025C
SAFETY DEVICE	HIGH PRESSURE SWITCH	TYPE	N/A	N/A
		OPEN	kPa / psi	N/A
		CLOSE	kPa / psi	N/A
	LOW PRESSURE SWITCH	TYPE	N/A	N/A
		OPEN	kPa / psi	N/A
		CLOSE	kPa / psi	N/A
	PHASE SEQUENCER - 1Ø / <3Ø>		N/A / <YES>	N/A / <YES>
	DISCHARGE THERMOSTAT SETTING - 1Ø / <3Ø>		°C / °F	N/A / <130 / 266>

MODEL	INDOOR UNIT		M5CC 028C	
	OUTDOOR UNIT		M5LC 028C	A5LC 035C
SAFETY DEVICE	HIGH PRESSURE SWITCH	TYPE	N/A	NC
		OPEN	kPa / psi	4137 / 600
		CLOSE	kPa / psi	3310 / 480
	LOW PRESSURE SWITCH	TYPE	N/A	NC
		OPEN	kPa / psi	48 / 7
		CLOSE	kPa / psi	152 / 22
	PHASE SEQUENCER - 1Ø / <3Ø>		N/A / <YES>	N/A / <YES>
	DISCHARGE THERMOSTAT SETTING - 1Ø / <3Ø>		°C / °F	N/A / <130 / 266>

MODEL	INDOOR UNIT		M5CC 038C	
	OUTDOOR UNIT		M5LC 040C	
SAFETY DEVICE	HIGH PRESSURE SWITCH	TYPE	NC	
		OPEN	kPa / psi	4137 / 600
		CLOSE	kPa / psi	3310 / 480
	LOW PRESSURE SWITCH	TYPE	NC	
		OPEN	kPa / psi	48 / 7
		CLOSE	kPa / psi	152 / 22
	PHASE SEQUENCER - 1Ø / <3Ø>		N/A / <YES>	
	DISCHARGE THERMOSTAT SETTING - 1Ø / <3Ø>		°C / °F	N/A / <130 / 266>

1) ALL SPECIFICATIONS ARE SUBJECTED TO CHANGE BY THE MANUFACTURER WITHOUT PRIOR NOTICE.

Safety Devices

MODEL	INDOOR UNIT		M5CC 050C	M5CC 060C
	OUTDOOR UNIT		M5LC 050C	M5LC 061C
SAFETY DEVICE	HIGH PRESSURE SWITCH	TYPE	NC	NC
		OPEN	kPa / psi	4137 / 600
		CLOSE	kPa / psi	3310 / 480
	LOW PRESSURE SWITCH	TYPE	NC	NC
		OPEN	kPa / psi	48 / 7
		CLOSE	kPa / psi	152 / 22
	PHASE SEQUENCER		YES	YES
	DISCHARGE THERMOSTAT SETTING		°C / °F	130 / 266

MODEL	INDOOR UNIT		M5CC 010CR	M5CC 015CR
	OUTDOOR UNIT		M5LC 010CR	M5LC 015CR
SAFETY DEVICE	HIGH PRESSURE SWITCH	TYPE	N/A	N/A
		OPEN	kPa / psi	N/A
		CLOSE	kPa / psi	N/A
	LOW PRESSURE SWITCH	TYPE	N/A	N/A
		OPEN	kPa / psi	N/A
		CLOSE	kPa / psi	N/A
	PHASE SEQUENCER		N/A	N/A
	DISCHARGE THERMOSTAT SETTING		°C / °F	N/A

MODEL	INDOOR UNIT		M5CC 020CR	M5CC 025CR
	OUTDOOR UNIT		M5LC 020CR	M5LC 025CR
SAFETY DEVICE	HIGH PRESSURE SWITCH	TYPE	N/A	N/A
		OPEN	kPa / psi	N/A
		CLOSE	kPa / psi	N/A
	LOW PRESSURE SWITCH	TYPE	N/A	N/A
		OPEN	kPa / psi	N/A
		CLOSE	kPa / psi	N/A
	PHASE SEQUENCER - 1Ø / <3Ø>		N/A / <YES>	N/A / <YES>
	DISCHARGE THERMOSTAT SETTING - 1Ø / <3Ø>		°C / °F	N/A / <130 / 266>

MODEL	INDOOR UNIT		M5CC 028CR	
	OUTDOOR UNIT		M5LC 028CR	M5LC 035CR
SAFETY DEVICE	HIGH PRESSURE SWITCH	TYPE	N/A	NC
		OPEN	kPa / psi	4137 / 600
		CLOSE	kPa / psi	3310 / 480
	LOW PRESSURE SWITCH	TYPE	N/A	NC
		OPEN	kPa / psi	48 / 7
		CLOSE	kPa / psi	152 / 22
	PHASE SEQUENCER - 1Ø / <3Ø>		N/A / <YES>	N/A / <YES>
	DISCHARGE THERMOSTAT SETTING - 1Ø / <3Ø>		°C / °F	N/A / <130 / 266>

1) ALL SPECIFICATIONS ARE SUBJECTED TO CHANGE BY THE MANUFACTURER WITHOUT PRIOR NOTICE.

Safety Devices

MODEL	INDOOR UNIT		M5CC 038CR	
	OUTDOOR UNIT		M5LC 040CR	
SAFETY DEVICE	HIGH PRESSURE SWITCH	TYPE		NC
		OPEN	kPa / psi	4137 / 600
		CLOSE	kPa / psi	3310 / 480
	LOW PRESSURE SWITCH	TYPE		NC
		OPEN	kPa / psi	48 / 7
		CLOSE	kPa / psi	152 / 22
	PHASE SEQUENCER - 1Ø / <3Ø>			N/A / <YES>
	DISCHARGE THERMOSTAT SETTING - 1Ø / <3Ø>			°C / °F

MODEL	INDOOR UNIT		M5CC 050CR		M5CC 060CR	
	OUTDOOR UNIT		M5LC 050CR		M5LC 061CR	
SAFETY DEVICE	HIGH PRESSURE SWITCH	TYPE		NC	NC	
		OPEN	kPa / psi	4137 / 600	4137 / 600	
		CLOSE	kPa / psi	3310 / 480	3310 / 480	
	LOW PRESSURE SWITCH	TYPE		NC	NC	
		OPEN	kPa / psi	48/7	48 / 7	
		CLOSE	kPa / psi	152 / 22	152 / 22	
	PHASE SEQUENCER - 1Ø / <3Ø>			YES	YES	
	DISCHARGE THERMOSTAT SETTING - 1Ø / <3Ø>			°C / °F	130 / 266	130 / 266

1) ALL SPECIFICATIONS ARE SUBJECTED TO CHANGE BY THE MANUFACTURER WITHOUT PRIOR NOTICE.

Performance Data

Interpolation and *Extrapolation* method can be used to get the total capacity, TC and sensible capacity, SC at those temperatures which are not stated out in the table.

Example:

Model: MCC 010C – MLC 010C

Indoor Condition: 23°C DB, 15°C WB

Outdoor Condition: 37°C DB

Solution:

Overall

Based on the Performance table on Pg.127

1. Refer to the Indoor DB column,
 - **23°C** is located between 20°C and 24°C (Thus, Interpolation need to be applied)
2. Refer to the Indoor WB column,
 - **15°C** only available in the case of Indoor DB = 20°C. (Thus, Extrapolation between 16°C WB and 17°C WB during 24°C indoor DB is required)
3. Refer to the Outdoor DB column,
 - **37°C** is located between 35°C and 40°C. (Thus, Interpolation need to be applied)

Please follow the steps below in order to get the required capacity.

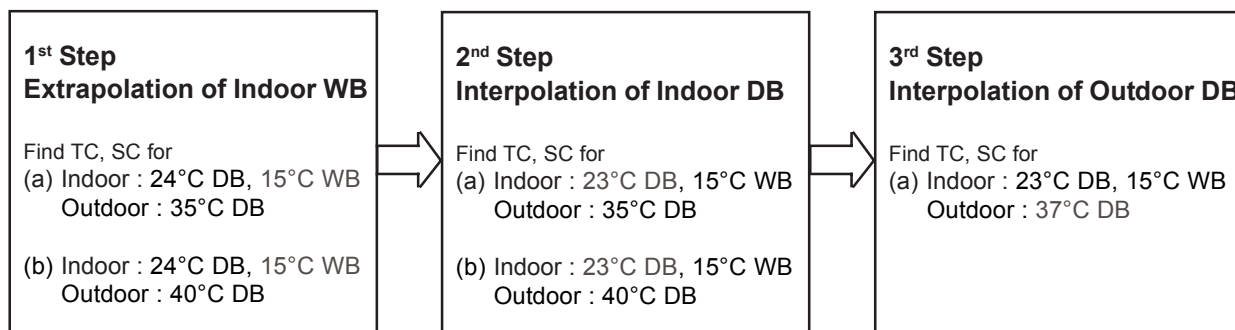

Details:

1st Step:

To obtain the Total capacity and Sensible capacity for

(a) Indoor Condition: 24°C DB, 15°C WB

Outdoor Condition: 35°C DB

Indoor DB °C	Indoor WB °C	Outdoor DB °C		
		35		
			TC (kW)	SC (kW)
24	15	-----	x_1	y_1
	16		2.598	1.904
	17		2.670	1.819

Total capacity, TC

⇒ $x_1 = 2.526\text{kW}$ (Same as Total capacity at 20 °C Indoor DB / 15 °C Indoor WB & 35 °C Outdoor WB)*

Sensible capacity, SC

Extrapolation Method:

$$\Rightarrow \frac{17^\circ\text{C} - 15^\circ\text{C}}{17^\circ\text{C} - 16^\circ\text{C}} = \frac{1.819\text{kW} - y_1}{1.819\text{kW} - 1.904\text{kW}}$$

$$\Rightarrow y_1 = 1.989\text{kW}$$

(b) Indoor Condition: 24°C DB, 15°C WB

Outdoor Condition: 40°C DB

Indoor DB °C	Indoor WB °C	Outdoor DB °C		
		40		
			TC (kW)	SC (kW)
24	15	-----	x_2	y_2
	16		2.410	1.701
	17		2.480	1.613

Total capacity, TC

⇒ $x_2 = 2.335\text{kW}$ (Same as Total capacity at 20 °C Indoor DB / 15 °C Indoor WB & 40 °C Outdoor WB)*

Sensible capacity, SC

Extrapolation Method:

$$\Rightarrow \frac{17^\circ\text{C} - 15^\circ\text{C}}{17^\circ\text{C} - 16^\circ\text{C}} = \frac{1.613\text{kW} - y_2}{1.613\text{kW} - 1.701\text{kW}}$$

$$\Rightarrow y_2 = 1.789\text{kW}$$

* This is due to 2 different conditions with same WB temperature, will have the same level of enthalpy. For more details, please refer to psychrometrics chart

2nd Step:

To obtain the Total capacity and Sensible capacity for

(a) Indoor Condition: 23°C DB, 15°C WB

Outdoor Condition: 35°C DB

Indoor DB ° C	Indoor WB ° C	Outdoor DB ° C	
		35	
		TC (kW)	SC (kW)
20	15	2.526	1.449
23	15	x ₃	y ₃
24	15	2.526	1.989

Total capacity, TC

$$\Rightarrow x_3 = 2.526\text{kW (Same as Total capacity at } 20^\circ\text{C Indoor DB / } 15^\circ\text{C Indoor WB \& } 35^\circ\text{C Outdoor WB)*}$$

Sensible capacity, SC

Interpolation Method:

$$\Rightarrow \frac{24^\circ\text{C} - 20^\circ\text{C}}{24^\circ\text{C} - 23^\circ\text{C}} = \frac{1.989\text{kW} - 1.449\text{kW}}{1.989\text{kW} - y_3}$$

$$\Rightarrow y_3 = 1.854\text{kW}$$

(b) Indoor Condition: 23°C DB, 15°C WB

Outdoor Condition: 40°C DB

Indoor DB ° C	Indoor WB ° C	Outdoor DB ° C	
		40	
		TC (kW)	SC (kW)
20	15	2.335	1.250
23	15	x ₄	y ₄
24	15	2.335	1.789

Total capacity, TC

$$\Rightarrow x_4 = 2.335\text{kW (Same as Total capacity at } 20^\circ\text{C Indoor DB / } 15^\circ\text{C Indoor WB \& } 40^\circ\text{C Outdoor WB)*}$$

Sensible capacity, SC

Interpolation Method:

$$\Rightarrow \frac{24^\circ\text{C} - 20^\circ\text{C}}{24^\circ\text{C} - 23^\circ\text{C}} = \frac{1.789\text{kW} - 1.250\text{kW}}{1.789\text{kW} - y_4}$$

$$\Rightarrow y_4 = 1.654\text{kW}$$

* This is due to 2 different conditions with same WB temperature will have the same level of enthalpy. For more details, please refer to psychrometrics chart

3rd Step:

To obtain the Total capacity and Sensible capacity for

(a) Indoor Condition: 23°C DB, 15°C WB

Outdoor Condition: 37°C DB

Indoor DB ° C	Indoor WB ° C	Outdoor DB ° C						
		35		37		40		
		TC (kW)	SC (kW)	TC (kW)	SC (kW)	TC (kW)	SC (kW)	
23	15	-----	2.526	1.854	x	y	2.335	1.654

Total capacity, TC

Interpolation Method:

$$\Rightarrow \frac{40^{\circ}\text{C} - 35^{\circ}\text{C}}{40^{\circ}\text{C} - 37^{\circ}\text{C}} = \frac{2.335\text{kW} - 2.526\text{kW}}{2.335\text{kW} - x}$$

$$\Rightarrow x = 2.450\text{kW}$$

Sensible capacity, SC

Interpolation Method:

$$\Rightarrow \frac{40^{\circ}\text{C} - 35^{\circ}\text{C}}{40^{\circ}\text{C} - 37^{\circ}\text{C}} = \frac{1.654\text{kW} - 1.854\text{kW}}{1.654\text{kW} - y}$$

$$\Rightarrow y = 1.774\text{kW}$$

(Cooling only)

Model : MCC 010C / MLC 010C

ID DB°C	ID WB°C	Outdoor DB°C											
		20		25		30		35		40		46	
		TC(kW)	SC(kW)	TC(kW)	SC(kW)	TC(kW)	SC(kW)	TC(kW)	SC(kW)	TC(kW)	SC(kW)	TC(kW)	SC(kW)
20	15	3.100	2.045	2.909	1.846	2.717	1.648	2.526	1.449	2.335	1.250	2.105	1.012
	16	3.162	1.971	2.974	1.769	2.786	1.566	2.598	1.364	2.410	1.162	2.184	0.919
24	16	3.162	2.511	2.974	2.309	2.786	2.106	2.598	1.904	2.410	1.701	2.184	1.459
	17	3.224	2.437	3.039	2.231	2.855	2.025	2.670	1.819	2.485	1.613	2.264	1.366
	18	3.286	2.363	3.105	2.154	2.923	1.944	2.742	1.734	2.561	1.525	2.343	1.273
	19	3.348	2.289	3.170	2.076	2.992	1.863	2.814	1.650	2.636	1.436	2.422	1.180
	20	3.410	2.216	3.234	2.006	3.059	1.795	2.883	1.585	2.707	1.374	2.496	1.121
28	18	3.286	2.903	3.105	2.693	2.923	2.484	2.742	2.274	2.561	2.064	2.343	1.813
	19	3.348	2.829	3.170	2.616	2.992	2.403	2.814	2.189	2.636	1.976	2.422	1.720
	20	3.410	2.756	3.234	2.545	3.059	2.335	2.883	2.124	2.707	1.914	2.496	1.661
	21	3.472	2.683	3.298	2.480	3.124	2.276	2.949	2.072	2.775	1.869	2.566	1.624
	22	3.534	2.611	3.361	2.414	3.189	2.217	3.016	2.020	2.844	1.824	2.637	1.587
	23	3.596	2.538	3.425	2.348	3.254	2.158	3.083	1.968	2.912	1.779	2.707	1.551
	24	3.658	2.465	3.488	2.282	3.319	2.099	3.150	1.916	2.980	1.733	2.777	1.514
30	20	3.410	3.026	3.234	2.815	3.059	2.605	2.883	2.394	2.707	2.184	2.496	1.931
	21	3.472	2.953	3.298	2.749	3.124	2.546	2.949	2.342	2.775	2.138	2.566	1.894
	22	3.534	2.880	3.361	2.684	3.189	2.487	3.016	2.290	2.844	2.093	2.637	1.857
	23	3.596	2.808	3.425	2.618	3.254	2.428	3.083	2.238	2.912	2.048	2.707	1.821
	24	3.658	2.735	3.488	2.552	3.319	2.369	3.150	2.186	2.980	2.003	2.777	1.784

Model : MCC 015C / MLC 015C

ID DB°C	ID WB°C	Outdoor DB°C											
		20		25		30		35		40		46	
		TC(kW)	SC(kW)	TC(kW)	SC(kW)	TC(kW)	SC(kW)	TC(kW)	SC(kW)	TC(kW)	SC(kW)	TC(kW)	SC(kW)
20	15	4.482	2.512	4.140	2.182	3.799	1.852	3.458	1.523	3.116	1.193	2.707	0.797
	16	4.485	2.226	4.159	1.923	3.834	1.620	3.508	1.317	3.183	1.014	2.792	0.651
24	16	4.485	3.215	4.159	2.912	3.834	2.609	3.508	2.306	3.183	2.003	2.792	1.640
	17	4.488	2.930	4.178	2.654	3.869	2.378	3.559	2.101	3.249	1.825	2.877	1.493
	18	4.492	2.645	4.197	2.396	3.903	2.146	3.609	1.896	3.315	1.646	2.962	1.347
	19	4.495	2.360	4.216	2.137	3.938	1.914	3.660	1.691	3.382	1.468	3.048	1.200
	20	4.498	2.076	4.239	1.890	3.979	1.703	3.720	1.517	3.460	1.330	3.149	1.106
28	18	4.492	3.634	4.197	3.385	3.903	3.135	3.609	2.885	3.315	2.635	2.962	2.336
	19	4.495	3.349	4.216	3.126	3.938	2.903	3.660	2.680	3.382	2.457	3.048	2.189
	20	4.498	3.065	4.239	2.879	3.979	2.692	3.720	2.506	3.460	2.319	3.149	2.095
	21	4.502	2.782	4.263	2.639	4.025	2.495	3.786	2.352	3.547	2.209	3.260	2.037
	22	4.506	2.499	4.288	2.399	4.070	2.299	3.852	2.198	3.634	2.098	3.372	1.978
	23	4.510	2.216	4.313	2.159	4.115	2.102	3.918	2.045	3.721	1.988	3.484	1.919
	24	4.514	1.933	4.337	1.919	4.161	1.905	3.984	1.891	3.807	1.877	3.595	1.860
30	20	4.498	3.560	4.239	3.373	3.979	3.187	3.720	3.000	3.460	2.814	3.149	2.590
	21	4.502	3.277	4.263	3.133	4.025	2.990	3.786	2.847	3.547	2.703	3.260	2.531
	22	4.506	2.994	4.288	2.893	4.070	2.793	3.852	2.693	3.634	2.593	3.372	2.472
	23	4.510	2.710	4.313	2.653	4.115	2.596	3.918	2.539	3.721	2.482	3.484	2.414
	24	4.514	2.427	4.337	2.413	4.161	2.399	3.984	2.386	3.807	2.372	3.595	2.355

R22 Models (Cooling only)

Model : MCC 020C / MLC 018C

ID DB°C	ID WB°C	Outdoor DB°C											
		20		25		30		35		40		46	
		TC(kW)	SC(kW)	TC(kW)	SC(kW)	TC(kW)	SC(kW)	TC(kW)	SC(kW)	TC(kW)	SC(kW)	TC(kW)	SC(kW)
20	15	6.110	3.546	5.693	3.178	5.275	2.811	4.858	2.443	4.441	2.075	3.940	1.634
	16	6.252	3.215	5.827	2.886	5.403	2.557	4.978	2.227	4.554	1.898	4.044	1.503
24	16	6.252	4.441	5.827	4.112	5.403	3.782	4.978	3.453	4.554	3.124	4.044	2.729
	17	6.394	4.110	5.962	3.819	5.530	3.528	5.099	3.238	4.667	2.947	4.149	2.598
	18	6.535	3.778	6.097	3.526	5.658	3.274	5.219	3.022	4.780	2.770	4.253	2.468
	19	6.677	3.447	6.231	3.234	5.785	3.020	5.339	2.807	4.893	2.593	4.358	2.337
	20	6.820	3.116	6.376	2.938	5.932	2.760	5.489	2.583	5.045	2.405	4.512	2.192
28	18	6.535	5.004	6.097	4.752	5.658	4.500	5.219	4.248	4.780	3.996	4.253	3.694
	19	6.677	4.673	6.231	4.460	5.785	4.246	5.339	4.033	4.893	3.819	4.358	3.563
	20	6.820	4.342	6.376	4.164	5.932	3.986	5.489	3.809	5.045	3.631	4.512	3.418
	21	6.964	4.010	6.528	3.866	6.093	3.723	5.658	3.579	5.222	3.435	4.700	3.263
	22	7.107	3.678	6.680	3.569	6.254	3.459	5.827	3.349	5.400	3.239	4.888	3.107
	23	7.251	3.347	6.833	3.271	6.414	3.195	5.996	3.119	5.577	3.043	5.075	2.952
	24	7.395	3.015	6.985	2.973	6.575	2.931	6.165	2.889	5.755	2.847	5.263	2.797
30	20	6.820	4.955	6.376	4.777	5.932	4.599	5.489	4.422	5.045	4.244	4.512	4.031
	21	6.964	4.623	6.528	4.479	6.093	4.336	5.658	4.192	5.222	4.048	4.700	3.876
	22	7.107	4.291	6.680	4.181	6.254	4.072	5.827	3.962	5.400	3.852	4.888	3.720
	23	7.251	3.960	6.833	3.884	6.414	3.808	5.996	3.732	5.577	3.656	5.075	3.565
	24	7.395	3.628	6.985	3.586	6.575	3.544	6.165	3.502	5.755	3.460	5.263	3.410

Model : MCC 020C / MLC 020C

ID DB°C	ID WB°C	Outdoor DB°C											
		20		25		30		35		40		46	
		TC(kW)	SC(kW)	TC(kW)	SC(kW)	TC(kW)	SC(kW)	TC(kW)	SC(kW)	TC(kW)	SC(kW)	TC(kW)	SC(kW)
20	15	6.380	3.850	5.959	3.412	5.539	2.975	5.118	2.537	4.698	2.100	4.194	1.575
	16	6.491	3.642	6.077	3.195	5.662	2.749	5.247	2.302	4.833	1.856	4.336	1.320
24	16	6.491	4.949	6.077	4.502	5.662	4.056	5.247	3.609	4.833	3.162	4.336	2.627
	17	6.602	4.741	6.194	4.285	5.785	3.830	5.377	3.374	4.968	2.918	4.478	2.372
	18	6.714	4.533	6.311	4.069	5.908	3.604	5.506	3.139	5.103	2.675	4.620	2.117
	19	6.825	4.326	6.428	3.852	6.032	3.378	5.635	2.904	5.238	2.431	4.762	1.862
	20	6.937	4.121	6.548	3.663	6.159	3.206	5.770	2.748	5.381	2.290	4.915	1.741
28	18	6.714	5.840	6.311	5.375	5.908	4.911	5.506	4.446	5.103	3.981	4.620	3.424
	19	6.825	5.632	6.428	5.159	6.032	4.685	5.635	4.211	5.238	3.737	4.762	3.169
	20	6.937	5.428	6.548	4.970	6.159	4.512	5.770	4.055	5.381	3.597	4.915	3.048
	21	7.049	5.225	6.669	4.800	6.290	4.376	5.910	3.951	5.530	3.526	5.075	3.016
	22	7.161	5.022	6.790	4.631	6.420	4.239	6.050	3.847	5.679	3.455	5.235	2.984
	23	7.273	4.820	6.912	4.461	6.551	4.102	6.190	3.743	5.829	3.383	5.395	2.953
	24	7.384	4.617	7.033	4.291	6.681	3.965	6.329	3.639	5.978	3.312	5.556	2.921
30	20	6.937	6.081	6.548	5.624	6.159	5.166	5.770	4.708	5.381	4.250	4.915	3.701
	21	7.049	5.879	6.669	5.454	6.290	5.029	5.910	4.604	5.530	4.179	5.075	3.669
	22	7.161	5.676	6.790	5.284	6.420	4.892	6.050	4.500	5.679	4.108	5.235	3.638
	23	7.273	5.473	6.912	5.114	6.551	4.755	6.190	4.396	5.829	4.037	5.395	3.606
	24	7.384	5.271	7.033	4.944	6.681	4.618	6.329	4.292	5.978	3.966	5.556	3.574

R22 Models (Cooling only)

Model : MCC 025C / MLC 025C

ID DB°C	ID WB°C	Outdoor DB°C											
		20		25		30		35		40		46	
		TC(kW)	SC(kW)	TC(kW)	SC(kW)	TC(kW)	SC(kW)	TC(kW)	SC(kW)	TC(kW)	SC(kW)	TC(kW)	SC(kW)
20	15	7.897	5.094	7.390	4.587	6.883	4.080	6.377	3.572	5.870	3.065	5.262	2.456
	16	7.913	4.608	7.451	4.144	6.988	3.681	6.525	3.217	6.063	2.753	5.507	2.196
24	16	7.913	5.951	7.451	5.488	6.988	5.024	6.525	4.560	6.063	4.096	5.507	3.539
	17	7.930	5.465	7.511	5.045	7.092	4.625	6.674	4.204	6.255	3.784	5.753	3.280
	18	7.946	4.979	7.571	4.602	7.197	4.225	6.822	3.849	6.448	3.472	5.998	3.020
	19	7.962	4.493	7.632	4.159	7.301	3.826	6.971	3.493	6.641	3.160	6.244	2.760
	20	7.977	4.008	7.676	3.731	7.374	3.454	7.073	3.177	6.772	2.900	6.411	2.567
28	18	7.946	6.322	7.571	5.945	7.197	5.569	6.822	5.192	6.448	4.815	5.998	4.363
	19	7.962	5.836	7.632	5.503	7.301	5.170	6.971	4.836	6.641	4.503	6.244	4.103
	20	7.977	5.351	7.676	5.074	7.374	4.797	7.073	4.520	6.772	4.243	6.411	3.910
	21	7.990	4.867	7.708	4.655	7.427	4.442	7.145	4.229	6.863	4.017	6.525	3.761
	22	8.003	4.384	7.741	4.235	7.479	4.087	7.217	3.939	6.954	3.790	6.640	3.612
	23	8.017	3.900	7.774	3.816	7.531	3.732	7.288	3.648	7.046	3.564	6.754	3.464
30	24	8.030	3.416	7.807	3.397	7.583	3.377	7.360	3.358	7.137	3.338	6.869	3.315
	20	7.977	6.023	7.676	5.746	7.374	5.468	7.073	5.191	6.772	4.914	6.411	4.582
	21	7.990	5.539	7.708	5.326	7.427	5.114	7.145	4.901	6.863	4.688	6.525	4.433
	22	8.003	5.055	7.741	4.907	7.479	4.759	7.217	4.610	6.954	4.462	6.640	4.284
	23	8.017	4.571	7.774	4.487	7.531	4.404	7.288	4.320	7.046	4.236	6.754	4.135
24	8.030	4.088	7.807	4.068	7.583	4.049	7.360	4.029	7.137	4.010	6.869	3.986	

Model : MCC 028C / MLC 028C

ID DB°C	ID WB°C	Outdoor DB°C											
		20		25		30		35		40		46	
		TC(kW)	SC(kW)	TC(kW)	SC(kW)	TC(kW)	SC(kW)	TC(kW)	SC(kW)	TC(kW)	SC(kW)	TC(kW)	SC(kW)
20	15	9.392	6.255	8.730	5.590	8.068	4.925	7.405	4.260	6.743	3.595	5.949	2.797
	16	9.493	5.930	8.848	5.280	8.204	4.630	7.559	3.980	6.914	3.330	6.141	2.550
24	16	9.493	7.523	8.848	6.873	8.204	6.223	7.559	5.573	6.914	4.923	6.141	4.143
	17	9.594	7.199	8.967	6.564	8.339	5.929	7.712	5.294	7.085	4.659	6.333	3.897
	18	9.694	6.875	9.085	6.255	8.475	5.635	7.866	5.015	7.256	4.394	6.525	3.650
	19	9.795	6.551	9.203	5.946	8.611	5.341	8.019	4.735	7.427	4.130	6.717	3.404
	20	9.897	6.229	9.328	5.653	8.758	5.078	8.189	4.502	7.620	3.927	6.937	3.236
28	18	9.694	8.468	9.085	7.848	8.475	7.228	7.866	6.608	7.256	5.987	6.525	5.243
	19	9.795	8.144	9.203	7.539	8.611	6.934	8.019	6.328	7.427	5.723	6.717	4.997
	20	9.897	7.822	9.328	7.246	8.758	6.671	8.189	6.095	7.620	5.520	6.937	4.829
	21	9.999	7.501	9.456	6.965	8.913	6.429	8.371	5.893	7.828	5.357	7.177	4.714
	22	10.100	7.180	9.584	6.684	9.068	6.187	8.552	5.691	8.036	5.195	7.416	4.600
	23	10.202	6.859	9.712	6.402	9.223	5.946	8.733	5.489	8.243	5.033	7.655	4.485
30	24	10.304	6.538	9.841	6.121	9.377	5.704	8.914	5.287	8.451	4.870	7.895	4.370
	20	9.897	8.618	9.328	8.043	8.758	7.467	8.189	6.892	7.620	6.316	6.937	5.626
	21	9.999	8.297	9.456	7.762	8.913	7.226	8.371	6.690	7.828	6.154	7.177	5.511
	22	10.100	7.976	9.584	7.480	9.068	6.984	8.552	6.488	8.036	5.992	7.416	5.396
	23	10.202	7.655	9.712	7.199	9.223	6.742	8.733	6.286	8.243	5.829	7.655	5.281
24	10.304	7.334	9.841	6.917	9.377	6.500	8.914	6.084	8.451	5.667	7.895	5.167	

R22 Models (Cooling only)

Model : MCC 028C / MLC 030C

ID DB°C	ID WB°C	Outdoor DB°C															
		20		25		30		35		40		46		50		54	
		TC(kW)	SC(kW)	TC(kW)	SC(kW)	TC(kW)	SC(kW)	TC(kW)	SC(kW)	TC(kW)	SC(kW)	TC(kW)	SC(kW)	TC(kW)	SC(kW)	TC(kW)	SC(kW)
20	15	9.475	5.888	8.887	5.381	8.298	4.874	7.710	4.367	7.340	4.030	6.954	3.679	6.654	3.405	6.319	3.100
	16	10.104	5.667	9.402	5.121	8.700	4.574	7.998	4.028	7.614	3.707	7.214	3.372	6.902	3.112	6.555	2.822
24	16	10.104	7.254	9.402	6.707	8.700	6.161	7.998	5.614	7.614	5.294	7.214	4.959	6.902	4.699	6.555	4.408
	17	10.732	7.033	9.917	6.447	9.101	5.861	8.286	5.275	7.888	4.971	7.474	4.653	7.151	4.406	6.791	4.130
	18	11.361	6.811	10.432	6.186	9.503	5.561	8.574	4.935	8.162	4.647	7.733	4.347	7.399	4.113	7.027	3.852
	19	11.989	6.590	10.947	5.925	9.904	5.261	8.862	4.596	8.437	4.324	7.993	4.041	7.648	3.820	7.263	3.574
	20	12.624	6.374	11.517	5.711	10.410	5.047	9.303	4.384	8.857	4.122	8.392	3.849	8.029	3.637	7.625	3.400
28	18	11.361	8.398	10.432	7.773	9.503	7.148	8.574	6.522	8.162	6.234	7.733	5.934	7.399	5.700	7.027	5.439
	19	11.989	8.177	10.947	7.512	9.904	6.848	8.862	6.183	8.437	5.911	7.993	5.628	7.648	5.407	7.263	5.161
	20	12.624	7.961	11.517	7.297	10.410	6.634	9.303	5.971	8.857	5.709	8.392	5.436	8.029	5.224	7.625	4.987
	21	13.263	7.748	12.124	7.113	10.986	6.478	9.848	5.844	9.376	5.588	8.883	5.322	8.499	5.114	8.071	4.883
	22	13.901	7.534	12.732	6.928	11.562	6.322	10.392	5.716	9.894	5.467	9.374	5.207	8.969	5.004	8.518	4.778
	23	14.540	7.321	13.339	6.744	12.138	6.167	10.937	5.589	10.412	5.346	9.865	5.092	9.439	4.894	8.964	4.674
	24	15.178	7.108	13.946	6.560	12.714	6.011	11.481	5.462	10.931	5.225	10.356	4.977	9.909	4.785	9.410	4.570
30	20	12.624	8.754	11.517	8.091	10.410	7.428	9.303	6.764	8.857	6.503	8.392	6.230	8.029	6.017	7.625	5.780
	21	13.263	8.541	12.124	7.906	10.986	7.272	9.848	6.637	9.376	6.382	8.883	6.115	8.499	5.907	8.071	5.676
	22	13.901	8.328	12.732	7.722	11.562	7.116	10.392	6.510	9.894	6.261	9.374	6.000	8.969	5.798	8.518	5.572
	23	14.540	8.115	13.339	7.537	12.138	6.960	10.937	6.383	10.412	6.139	9.865	5.886	9.439	5.688	8.964	5.468
	24	15.178	7.902	13.946	7.353	12.714	6.804	11.481	6.256	10.931	6.018	10.356	5.771	9.909	5.578	9.410	5.363

HIGH AMBIENT

Model : MCC 038C / MLC 035C

ID DB°C	ID WB°C	Outdoor DB°C											
		20		25		30		35		40		46	
		TC(kW)	SC(kW)	TC(kW)	SC(kW)	TC(kW)	SC(kW)	TC(kW)	SC(kW)	TC(kW)	SC(kW)	TC(kW)	SC(kW)
20	15	13.166	7.818	12.078	6.774	10.989	5.730	9.900	4.686	8.812	3.642	7.505	2.389
	16	13.389	7.410	12.270	6.373	11.150	5.336	10.031	4.299	8.911	3.262	7.568	2.017
24	16	13.389	10.168	12.270	9.130	11.150	8.093	10.031	7.056	8.911	6.019	7.568	4.774
	17	13.612	9.760	12.462	8.730	11.311	7.700	10.161	6.669	9.011	5.639	7.630	4.403
	18	13.835	9.352	12.654	8.329	11.472	7.306	10.291	6.283	9.110	5.259	7.693	4.032
	19	14.057	8.944	12.846	7.928	11.634	6.912	10.422	5.896	9.210	4.880	7.756	3.660
	20	14.287	8.541	13.097	7.568	11.907	6.595	10.718	5.622	9.528	4.649	8.100	3.481
28	18	13.835	12.109	12.654	11.086	11.472	10.063	10.291	9.040	9.110	8.017	7.693	6.789
	19	14.057	11.702	12.846	10.686	11.634	9.669	10.422	8.653	9.210	7.637	7.756	6.417
	20	14.287	11.298	13.097	10.325	11.907	9.352	10.718	8.379	9.528	7.406	8.100	6.238
	21	14.520	10.898	13.388	9.992	12.256	9.086	11.124	8.180	9.992	7.275	8.634	6.188
	22	14.753	10.497	13.679	9.659	12.605	8.820	11.530	7.982	10.456	7.143	9.167	6.137
	23	14.987	10.097	13.970	9.325	12.953	8.554	11.937	7.783	10.920	7.012	9.700	6.086
	24	15.220	9.696	14.261	8.992	13.302	8.288	12.343	7.584	11.384	6.880	10.233	6.035
30	20	14.287	12.677	13.097	11.704	11.907	10.731	10.718	9.758	9.528	8.785	8.100	7.617
	21	14.520	12.276	13.388	11.371	12.256	10.465	11.124	9.559	9.992	8.653	8.634	7.566
	22	14.753	11.876	13.679	11.037	12.605	10.199	11.530	9.360	10.456	8.522	9.167	7.515
	23	14.987	11.475	13.970	10.704	12.953	9.933	11.937	9.162	10.920	8.390	9.700	7.465
	24	15.220	11.075	14.261	10.371	13.302	9.667	12.343	8.963	11.384	8.259	10.233	7.414

R22 Models (Cooling only)

Model : MCC 038C / MLC 040C

ID DB°C	ID WB°C	Outdoor DB°C															
		20		25		30		35		40		46		50		54	
		TC(kW)	SC(kW)	TC(kW)	SC(kW)	TC(kW)	SC(kW)	TC(kW)	SC(kW)	TC(kW)	SC(kW)	TC(kW)	SC(kW)	TC(kW)	SC(kW)	TC(kW)	SC(kW)
20	15	14.822	8.775	13.547	7.589	12.273	6.403	10.999	5.216	10.072	4.349	9.142	3.480	8.795	3.155	8.666	3.034
	16	14.872	7.977	13.609	6.879	12.346	5.781	11.083	4.683	10.149	3.861	9.212	3.036	8.863	2.729	8.733	2.614
24	16	14.872	11.005	13.609	9.907	12.346	8.809	11.083	7.711	10.149	6.889	9.212	6.064	8.863	5.756	8.733	5.642
	17	14.923	10.207	13.671	9.197	12.420	8.187	11.168	7.178	10.227	6.401	9.283	5.621	8.930	5.330	8.800	5.222
	18	14.974	9.409	13.733	8.488	12.493	7.566	11.253	6.644	10.305	5.912	9.353	5.178	8.998	4.903	8.866	4.802
	19	15.024	8.611	13.795	7.778	12.567	6.944	11.338	6.111	10.382	5.424	9.424	4.734	9.066	4.477	8.933	4.381
28	20	15.080	7.815	13.910	7.088	12.740	6.361	11.570	5.634	10.595	4.987	9.617	4.338	9.252	4.096	9.116	4.006
	18	14.974	12.437	13.733	11.515	12.493	10.594	11.253	9.672	10.305	8.940	9.353	8.206	8.998	7.931	8.866	7.830
	19	15.024	11.639	13.795	10.806	12.567	9.972	11.338	9.139	10.382	8.452	9.424	7.762	9.066	7.505	8.933	7.409
	20	15.080	10.843	13.910	10.116	12.740	9.389	11.570	8.662	10.595	8.015	9.617	7.366	9.252	7.124	9.116	7.034
	21	15.140	10.049	14.060	9.441	12.980	8.832	11.900	8.224	10.897	7.614	9.891	7.002	9.516	6.773	9.376	6.688
	22	15.200	9.255	14.210	8.765	13.220	8.275	12.231	7.785	11.200	7.212	10.166	6.637	9.780	6.423	9.637	6.343
	23	15.260	8.460	14.360	8.089	13.461	7.718	12.561	7.347	11.503	6.811	10.441	6.273	10.044	6.072	9.897	5.997
30	24	15.320	7.666	14.511	7.413	13.701	7.161	12.891	6.908	11.805	6.409	10.715	5.908	10.308	5.721	10.157	5.652
	20	15.080	12.357	13.910	11.630	12.740	10.903	11.570	10.176	10.595	9.529	9.617	8.880	9.252	8.638	9.116	8.548
	21	15.140	11.563	14.060	10.954	12.980	10.346	11.900	9.738	10.897	9.128	9.891	8.516	9.516	8.287	9.376	8.202
	22	15.200	10.769	14.210	10.279	13.220	9.789	12.231	9.299	11.200	8.726	10.166	8.151	9.780	7.936	9.637	7.857
	23	15.260	9.974	14.360	9.603	13.461	9.232	12.561	8.861	11.503	8.324	10.441	7.787	10.044	7.586	9.897	7.511
	24	15.320	9.180	14.511	8.927	13.701	8.675	12.891	8.422	11.805	7.923	10.715	7.422	10.308	7.235	10.157	7.166
HIGH AMBIENT																	

Model : MCC 030C / MLC 028C

ID DB°C	ID WB°C	Outdoor DB°C											
		20		25		30		35		40		46	
		TC(kW)	SC(kW)	TC(kW)	SC(kW)	TC(kW)	SC(kW)	TC(kW)	SC(kW)	TC(kW)	SC(kW)	TC(kW)	SC(kW)
20	15	9.703	6.460	9.024	5.773	8.345	5.086	7.666	4.399	6.987	3.711	6.172	2.887
	16	9.810	6.128	9.150	5.452	8.489	4.775	7.828	4.098	7.168	3.422	6.375	2.610
24	16	9.810	7.774	9.150	7.098	8.489	6.421	7.828	5.744	7.168	5.068	6.375	4.256
	17	9.918	7.442	9.275	6.776	8.633	6.110	7.991	5.444	7.348	4.778	6.577	3.978
	18	10.025	7.110	9.401	6.455	8.777	5.799	8.153	5.144	7.529	4.488	6.780	3.701
	19	10.133	6.778	9.527	6.133	8.921	5.488	8.315	4.843	7.709	4.198	6.982	3.424
28	20	10.241	6.449	9.658	5.834	9.075	5.219	8.492	4.604	7.909	3.989	7.210	3.251
	18	10.025	8.756	9.401	8.101	8.777	7.445	8.153	6.789	7.529	6.134	6.780	5.347
	19	10.133	8.424	9.527	7.779	8.921	7.134	8.315	6.489	7.709	5.844	6.982	5.070
	20	10.241	8.095	9.658	7.480	9.075	6.865	8.492	6.250	7.909	5.635	7.210	4.897
	21	10.349	7.766	9.792	7.194	9.236	6.622	8.679	6.050	8.122	5.478	7.454	4.792
	22	10.458	7.438	9.927	6.909	9.396	6.380	8.866	5.851	8.335	5.322	7.698	4.688
	23	10.566	7.110	10.061	6.624	9.557	6.138	9.053	5.652	8.548	5.166	7.943	4.583
30	24	10.674	6.782	10.196	6.339	9.718	5.896	9.239	5.453	8.761	5.010	8.187	4.479
	20	10.241	8.917	9.658	8.302	9.075	7.687	8.492	7.072	7.909	6.457	7.210	5.719
	21	10.349	8.589	9.792	8.017	9.236	7.445	8.679	6.873	8.122	6.301	7.454	5.615
	22	10.458	8.261	9.927	7.732	9.396	7.203	8.866	6.674	8.335	6.145	7.698	5.511
	23	10.566	7.933	10.061	7.447	9.557	6.961	9.053	6.475	8.548	5.989	7.943	5.406
	24	10.674	7.605	10.196	7.162	9.718	6.719	9.239	6.276	8.761	5.833	8.187	5.302

R22 Models (Cooling only)

Model : MCC 030C / MLC 030C

ID DB°C	ID WB°C	Outdoor DB°C															
		20		25		30		35		40		46		50		54	
		TC(kW)	SC(kW)	TC(kW)	SC(kW)	TC(kW)	SC(kW)	TC(kW)	SC(kW)	TC(kW)	SC(kW)	TC(kW)	SC(kW)	TC(kW)	SC(kW)	TC(kW)	SC(kW)
20	15	9.018	5.769	8.500	5.377	7.983	4.984	7.465	4.591	7.107	4.255	6.734	3.904	6.443	3.630	6.118	3.325
	16	9.628	5.631	9.008	5.249	8.387	4.868	7.767	4.486	7.395	4.154	7.006	3.808	6.703	3.539	6.366	3.239
24	16	9.628	7.080	9.008	6.698	8.387	6.317	7.767	5.935	7.395	5.603	7.006	5.257	6.703	4.988	6.366	4.688
	17	10.238	6.942	9.515	6.571	8.792	6.200	8.069	5.829	7.682	5.503	7.278	5.162	6.964	4.897	6.613	4.601
	18	10.849	6.804	10.023	6.444	9.197	6.084	8.371	5.724	7.969	5.402	7.550	5.067	7.224	4.806	6.861	4.515
	19	11.459	6.667	10.530	6.317	9.601	5.968	8.673	5.618	8.257	5.302	7.823	4.972	7.485	4.715	7.108	4.428
	20	12.074	6.526	11.081	6.163	10.088	5.800	9.096	5.437	8.660	5.130	8.204	4.809	7.850	4.559	7.455	4.280
28	18	10.849	8.253	10.023	7.893	9.197	7.533	8.371	7.173	7.969	6.851	7.550	6.516	7.224	6.255	6.861	5.964
	19	11.459	8.115	10.530	7.766	9.601	7.417	8.673	7.067	8.257	6.751	7.823	6.421	7.485	6.164	7.108	5.877
	20	12.074	7.975	11.081	7.612	10.088	7.249	9.096	6.886	8.660	6.579	8.204	6.258	7.850	6.008	7.455	5.729
	21	12.692	7.832	11.661	7.439	10.630	7.047	9.599	6.655	9.139	6.358	8.659	6.049	8.285	5.808	7.868	5.539
	22	13.310	7.689	12.241	7.267	11.172	6.845	10.103	6.423	9.619	6.138	9.113	5.840	8.720	5.608	8.281	5.349
	23	13.928	7.546	12.821	7.095	11.714	6.643	10.607	6.192	10.098	5.917	9.568	5.631	9.154	5.408	8.694	5.160
30	24	14.547	7.404	13.401	6.923	12.256	6.441	11.111	5.960	10.578	5.697	10.022	5.422	9.589	5.208	9.106	4.970
	20	12.074	8.699	11.081	8.336	10.088	7.973	9.096	7.611	8.660	7.303	8.204	6.982	7.850	6.732	7.455	6.453
	21	12.692	8.556	11.661	8.164	10.630	7.772	9.599	7.379	9.139	7.083	8.659	6.773	8.285	6.532	7.868	6.264
	22	13.310	8.414	12.241	7.992	11.172	7.570	10.103	7.148	9.619	6.862	9.113	6.564	8.720	6.332	8.281	6.074
	23	13.928	8.271	12.821	7.819	11.714	7.368	10.607	6.916	10.098	6.642	9.568	6.356	9.154	6.133	8.694	5.884
24	14.547	8.128	13.401	7.647	12.256	7.166	11.111	6.685	10.578	6.421	10.022	6.147	9.589	5.933	9.106	5.694	

HIGH AMBIENT

Model : MCC 040C / MLC 035C

ID DB°C	ID WB°C	Outdoor DB°C											
		20		25		30		35		40		46	
		TC(kW)	SC(kW)	TC(kW)	SC(kW)	TC(kW)	SC(kW)	TC(kW)	SC(kW)	TC(kW)	SC(kW)	TC(kW)	SC(kW)
20	15	11.875	7.511	11.081	6.740	10.287	5.968	9.493	5.196	8.698	4.425	7.745	3.499
	16	12.021	6.982	11.253	6.256	10.484	5.531	9.716	4.805	8.948	4.080	8.026	3.209
24	16	12.021	9.142	11.253	8.417	10.484	7.691	9.716	6.966	8.948	6.240	8.026	5.370
	17	12.166	8.612	11.424	7.933	10.682	7.254	9.939	6.575	9.197	5.895	8.306	5.080
	18	12.312	8.082	11.595	7.449	10.879	6.816	10.162	6.183	9.446	5.550	8.586	4.791
	19	12.457	7.552	11.767	6.966	11.076	6.379	10.386	5.792	9.695	5.206	8.866	4.502
	20	12.603	7.023	11.937	6.490	11.272	5.956	10.606	5.423	9.941	4.889	9.142	4.249
28	18	12.312	10.243	11.595	9.610	10.879	8.977	10.162	8.344	9.446	7.711	8.586	6.951
	19	12.457	9.713	11.767	9.126	11.076	8.539	10.386	7.953	9.695	7.366	8.866	6.662
	20	12.603	9.184	11.937	8.650	11.272	8.117	10.606	7.583	9.941	7.050	9.142	6.409
	21	12.748	8.655	12.107	8.180	11.466	7.704	10.825	7.228	10.184	6.752	9.415	6.181
	22	12.893	8.127	12.277	7.709	11.661	7.291	11.044	6.873	10.428	6.455	9.688	5.954
	23	13.039	7.598	12.447	7.238	11.855	6.878	11.263	6.518	10.671	6.158	9.961	5.726
30	24	13.184	7.070	12.617	6.768	12.049	6.465	11.482	6.163	10.915	5.861	10.234	5.498
	20	12.603	10.264	11.937	9.730	11.272	9.197	10.606	8.663	9.941	8.130	9.142	7.490
	21	12.748	9.736	12.107	9.260	11.466	8.784	10.825	8.308	10.184	7.833	9.415	7.262
	22	12.893	9.207	12.277	8.789	11.661	8.371	11.044	7.953	10.428	7.535	9.688	7.034
	23	13.039	8.679	12.447	8.318	11.855	7.958	11.263	7.598	10.671	7.238	9.961	6.806
24	13.184	8.150	12.617	7.848	12.049	7.545	11.482	7.243	10.915	6.941	10.234	6.578	

**R22 Models
(Cooling only)**

Model : MCC 040C / MLC 040C

ID DB°C	ID WB°C	Outdoor DB°C															
		20		25		30		35		40		46		50		54	
		TC(kW)	SC(kW)	TC(kW)	SC(kW)	TC(kW)	SC(kW)	TC(kW)	SC(kW)	TC(kW)	SC(kW)	TC(kW)	SC(kW)	TC(kW)	SC(kW)	TC(kW)	SC(kW)
20	15	12.360	8.239	11.670	7.643	10.979	7.047	10.288	6.451	9.422	5.635	8.552	4.817	8.227	4.511	8.107	4.398
	16	12.579	7.644	11.924	7.170	11.269	6.697	10.615	6.223	9.720	5.426	8.823	4.627	8.488	4.329	8.363	4.218
24	16	12.579	9.572	11.924	9.099	11.269	8.625	10.615	8.151	9.720	7.355	8.823	6.555	8.488	6.257	8.363	6.146
	17	12.797	8.978	12.179	8.626	11.560	8.275	10.941	7.923	10.019	7.146	9.094	6.366	8.749	6.075	8.620	5.967
	18	13.016	8.384	12.433	8.154	11.850	7.924	11.267	7.695	10.317	6.937	9.365	6.176	9.009	5.892	8.877	5.787
	19	13.235	7.789	12.687	7.682	12.140	7.574	11.593	7.467	10.616	6.728	9.636	5.987	9.270	5.710	9.134	5.607
	20	13.450	7.186	12.915	7.130	12.380	7.075	11.846	7.019	10.847	6.318	9.846	5.615	9.472	5.352	9.333	5.254
28	18	13.016	10.312	12.433	10.082	11.850	9.853	11.267	9.623	10.317	8.865	9.365	8.105	9.009	7.821	8.877	7.715
	19	13.235	9.717	12.687	9.610	12.140	9.502	11.593	9.395	10.616	8.656	9.636	7.915	9.270	7.638	9.134	7.535
	20	13.450	9.114	12.915	9.059	12.380	9.003	11.846	8.947	10.847	8.246	9.846	7.543	9.472	7.280	9.333	7.183
	21	13.664	8.506	13.126	8.455	12.588	8.404	12.049	8.354	11.034	7.702	10.015	7.049	9.635	6.805	9.494	6.715
	22	13.878	7.897	13.336	7.851	12.795	7.806	12.253	7.760	11.220	7.159	10.185	6.556	9.798	6.330	9.654	6.247
	23	14.092	7.289	13.547	7.248	13.002	7.207	12.457	7.166	11.407	6.615	10.354	6.062	9.961	5.856	9.815	5.779
24	14.306	6.680	13.757	6.644	13.209	6.608	12.660	6.572	11.593	6.071	10.523	5.568	10.124	5.381	9.975	5.311	
30	20	13.450	10.079	12.915	10.023	12.380	9.967	11.846	9.912	10.847	9.210	9.846	8.507	9.472	8.244	9.333	8.147
	21	13.664	9.470	13.126	9.419	12.588	9.368	12.049	9.318	11.034	8.667	10.015	8.013	9.635	7.770	9.494	7.679
	22	13.878	8.862	13.336	8.816	12.795	8.770	12.253	8.724	11.220	8.123	10.185	7.520	9.798	7.295	9.654	7.211
	23	14.092	8.253	13.547	8.212	13.002	8.171	12.457	8.130	11.407	7.579	10.354	7.026	9.961	6.820	9.815	6.743
	24	14.306	7.644	13.757	7.608	13.209	7.572	12.660	7.536	11.593	7.035	10.523	6.533	10.124	6.345	9.975	6.275

HIGH AMBIENT

Model : MCC 050C / MLC 050C

ID DB°C	ID WB°C	Outdoor DB°C															
		20		25		30		35		40		46		50		54	
		TC(kW)	SC(kW)	TC(kW)	SC(kW)	TC(kW)	SC(kW)	TC(kW)	SC(kW)	TC(kW)	SC(kW)	TC(kW)	SC(kW)	TC(kW)	SC(kW)	TC(kW)	SC(kW)
20	15	16.149	10.022	15.129	9.130	14.109	8.238	13.088	7.345	12.332	6.632	11.638	5.979	11.234	5.598	10.875	5.260
	16	16.445	9.279	15.445	8.523	14.445	7.766	13.444	7.010	12.667	6.317	11.955	5.681	11.539	5.311	11.171	4.982
24	16	16.445	12.254	15.445	11.498	14.445	10.742	13.444	9.985	12.667	9.292	11.955	8.657	11.539	8.286	11.171	7.957
	17	16.741	11.511	15.761	10.891	14.780	10.271	13.800	9.650	13.002	8.976	12.271	8.359	11.845	7.998	11.466	7.679
	18	17.037	10.768	16.077	10.284	15.116	9.799	14.156	9.315	13.338	8.661	12.588	8.061	12.150	7.711	11.762	7.400
	19	17.333	10.025	16.393	9.676	15.452	9.328	14.512	8.980	13.673	8.345	12.904	7.763	12.455	7.423	12.058	7.122
	20	17.629	9.273	16.705	8.995	15.782	8.717	14.858	8.438	13.999	7.834	13.212	7.281	12.753	6.958	12.346	6.672
28	18	17.037	13.743	16.077	13.259	15.116	12.775	14.156	12.290	13.338	11.636	12.588	11.036	12.150	10.686	11.762	10.375
	19	17.333	13.000	16.393	12.652	15.452	12.303	14.512	11.955	13.673	11.320	12.904	10.738	12.455	10.398	12.058	10.097
	20	17.629	12.249	16.705	11.970	15.782	11.692	14.858	11.413	13.999	10.809	13.212	10.256	12.753	9.933	12.346	9.647
	21	17.925	11.492	17.016	11.239	16.107	10.986	15.198	10.733	14.320	10.169	13.514	9.651	13.044	9.349	12.628	9.082
	22	18.220	10.736	17.326	10.508	16.432	10.281	15.538	10.053	14.640	9.528	13.817	9.046	13.336	8.765	12.911	8.517
	23	18.515	9.979	17.636	9.777	16.757	9.575	15.878	9.373	14.960	8.887	14.119	8.442	13.628	8.182	13.193	7.951
24	18.811	9.223	17.947	9.046	17.083	8.869	16.218	8.693	15.281	8.246	14.422	7.837	13.920	7.598	13.476	7.386	
30	20	17.629	13.736	16.705	13.458	15.782	13.179	14.858	12.901	13.999	12.297	13.212	11.743	12.753	11.420	12.346	11.134
	21	17.925	12.980	17.016	12.727	16.107	12.474	15.198	12.221	14.320	11.656	13.514	11.139	13.044	10.837	12.628	10.569
	22	18.220	12.223	17.326	11.996	16.432	11.768	15.538	11.541	14.640	11.015	13.817	10.534	13.336	10.253	12.911	10.004
	23	18.515	11.467	17.636	11.265	16.757	11.063	15.878	10.861	14.960	10.375	14.119	9.929	13.628	9.669	13.193	9.439
	24	18.811	10.710	17.947	10.534	17.083	10.357	16.218	10.180	15.281	9.734	14.422	9.325	13.920	9.086	13.476	8.874

HIGH AMBIENT

R22 Models (Cooling only)

Model : MCC 060C / MLC 061C

ID DB°C	ID WB°C	Outdoor DB°C											
		20		25		30		35		40		46	
		TC(kW)	SC(kW)	TC(kW)	SC(kW)	TC(kW)	SC(kW)	TC(kW)	SC(kW)	TC(kW)	SC(kW)	TC(kW)	SC(kW)
20	15	17.227	10.737	16.225	9.883	15.223	9.029	14.221	8.175	13.220	7.320	12.018	6.295
	16	17.950	10.202	16.873	9.406	15.796	8.610	14.719	7.815	13.642	7.019	12.350	6.064
24	16	17.950	13.244	16.873	12.449	15.796	11.653	14.719	10.857	13.642	10.062	12.350	9.107
	17	18.672	12.709	17.521	11.971	16.369	11.234	15.217	10.497	14.065	9.760	12.683	8.876
	18	19.395	12.173	18.168	11.494	16.941	10.816	15.714	10.137	14.487	9.459	13.015	8.645
	19	20.118	11.637	18.816	11.017	17.514	10.397	16.212	9.777	14.910	9.157	13.347	8.413
	20	20.844	11.097	19.492	10.501	18.140	9.905	16.788	9.309	15.436	8.713	13.813	7.998
28	18	19.395	15.215	18.168	14.537	16.941	13.858	15.714	13.180	14.487	12.501	13.015	11.687
	19	20.118	14.680	18.816	14.060	17.514	13.440	16.212	12.820	14.910	12.200	13.347	11.456
	20	20.844	14.140	19.492	13.544	18.140	12.948	16.788	12.352	15.436	11.756	13.813	11.041
	21	21.572	13.597	20.187	13.002	18.801	12.407	17.416	11.812	16.031	11.217	14.369	10.503
	22	22.300	13.054	20.881	12.460	19.463	11.866	18.044	11.272	16.626	10.678	14.924	9.965
	23	23.027	12.511	21.576	11.918	20.124	11.325	18.672	10.732	17.221	10.139	15.479	9.427
30	24	23.755	11.969	22.270	11.377	20.785	10.784	19.300	10.192	17.816	9.600	16.034	8.889
	20	20.844	15.661	19.492	15.065	18.140	14.469	16.788	13.873	15.436	13.277	13.813	12.562
	21	21.572	15.118	20.187	14.523	18.801	13.928	17.416	13.333	16.031	12.738	14.369	12.024
	22	22.300	14.576	20.881	13.981	19.463	13.387	18.044	12.793	16.626	12.199	14.924	11.486
	23	23.027	14.033	21.576	13.440	20.124	12.847	18.672	12.253	17.221	11.660	15.479	10.949
	24	23.755	13.490	22.270	12.898	20.785	12.306	19.300	11.713	17.816	11.121	16.034	10.411

R22 Models (Heatpump)

Model : MCC 010CR / MLC 010CR Cooling Mode

ID DB°C	ID WB°C	Outdoor DB°C											
		20		25		30		35		40		46	
		TC(kW)	SC(kW)	TC(kW)	SC(kW)	TC(kW)	SC(kW)	TC(kW)	SC(kW)	TC(kW)	SC(kW)	TC(kW)	SC(kW)
20	15	3.100	2.045	2.909	1.846	2.717	1.648	2.526	1.449	2.335	1.250	2.105	1.012
	16	3.162	1.971	2.974	1.769	2.786	1.566	2.598	1.364	2.410	1.162	2.184	0.919
24	16	3.162	2.511	2.974	2.309	2.786	2.106	2.598	1.904	2.410	1.701	2.184	1.459
	17	3.224	2.437	3.039	2.231	2.855	2.025	2.670	1.819	2.485	1.613	2.264	1.366
	18	3.286	2.363	3.105	2.154	2.923	1.944	2.742	1.734	2.561	1.525	2.343	1.273
	19	3.348	2.289	3.170	2.076	2.992	1.863	2.814	1.650	2.636	1.436	2.422	1.180
	20	3.410	2.216	3.234	2.006	3.059	1.795	2.883	1.585	2.707	1.374	2.496	1.121
	18	3.286	2.903	3.105	2.693	2.923	2.484	2.742	2.274	2.561	2.064	2.343	1.813
28	19	3.348	2.829	3.170	2.616	2.992	2.403	2.814	2.189	2.636	1.976	2.422	1.720
	20	3.410	2.756	3.234	2.545	3.059	2.335	2.883	2.124	2.707	1.914	2.496	1.661
	21	3.472	2.683	3.298	2.480	3.124	2.276	2.949	2.072	2.775	1.869	2.566	1.624
	22	3.534	2.611	3.361	2.414	3.189	2.217	3.016	2.020	2.844	1.824	2.637	1.587
	23	3.596	2.538	3.425	2.348	3.254	2.158	3.083	1.968	2.912	1.779	2.707	1.551
	24	3.658	2.465	3.488	2.282	3.319	2.099	3.150	1.916	2.980	1.733	2.777	1.514
30	20	3.410	3.026	3.234	2.815	3.059	2.605	2.883	2.394	2.707	2.184	2.496	1.931
	21	3.472	2.953	3.298	2.749	3.124	2.546	2.949	2.342	2.775	2.138	2.566	1.894
	22	3.534	2.880	3.361	2.684	3.189	2.487	3.016	2.290	2.844	2.093	2.637	1.857
	23	3.596	2.808	3.425	2.618	3.254	2.428	3.083	2.238	2.912	2.048	2.707	1.821
	24	3.658	2.735	3.488	2.552	3.319	2.369	3.150	2.186	2.980	2.003	2.777	1.784

Heating Mode

ID DB°C	Outdoor WB°C													
	-9		-6		-5		6		12		15		18	
	TC(kW)	SC(kW)	TC(kW)	SC(kW)	TC(kW)	SC(kW)	TC(kW)	SC(kW)	TC(kW)	SC(kW)	TC(kW)	SC(kW)	TC(kW)	SC(kW)
15	1.202	1.202	1.497	1.497	1.596	1.596	2.679	2.679	3.269	3.269	3.565	3.565	3.860	3.860
17	1.173	1.173	1.467	1.467	1.565	1.565	2.670	2.670	3.180	3.180	3.465	3.465	3.750	3.750
19	1.145	1.145	1.437	1.437	1.535	1.535	2.661	2.661	3.091	3.091	3.366	3.366	3.640	3.640
21	1.117	1.117	1.408	1.408	1.505	1.505	2.652	2.652	3.002	3.002	3.266	3.266	3.531	3.531
23	1.113	1.113	1.384	1.384	1.474	1.474	2.521	2.521	2.913	2.913	3.167	3.167	3.421	3.421
25	1.109	1.109	1.360	1.360	1.444	1.444	2.390	2.390	2.824	2.824	3.068	3.068	3.311	3.311
27	1.105	1.105	1.337	1.337	1.414	1.414	2.259	2.259	2.735	2.735	2.968	2.968	3.201	3.201
FROST REGION														

R22 Models (Heatpump)

Model : MCC 015CR / MLC 015CR

Cooling Mode

ID DB°C	ID WB°C	Outdoor DB°C											
		20		25		30		35		40		46	
		TC(kW)	SC(kW)	TC(kW)	SC(kW)	TC(kW)	SC(kW)	TC(kW)	SC(kW)	TC(kW)	SC(kW)	TC(kW)	SC(kW)
20	15	4.482	2.512	4.140	2.182	3.799	1.852	3.458	1.523	3.116	1.193	2.707	0.797
	16	4.485	2.226	4.159	1.923	3.834	1.620	3.508	1.317	3.183	1.014	2.792	0.651
24	16	4.485	3.215	4.159	2.912	3.834	2.609	3.508	2.306	3.183	2.003	2.792	1.640
	17	4.488	2.930	4.178	2.654	3.869	2.378	3.559	2.101	3.249	1.825	2.877	1.493
	18	4.492	2.645	4.197	2.396	3.903	2.146	3.609	1.896	3.315	1.646	2.962	1.347
	19	4.495	2.360	4.216	2.137	3.938	1.914	3.660	1.691	3.382	1.468	3.048	1.200
	20	4.498	2.076	4.239	1.890	3.979	1.703	3.720	1.517	3.460	1.330	3.149	1.106
	18	4.492	3.634	4.197	3.385	3.903	3.135	3.609	2.885	3.315	2.635	2.962	2.336
28	19	4.495	3.349	4.216	3.126	3.938	2.903	3.660	2.680	3.382	2.457	3.048	2.189
	20	4.498	3.065	4.239	2.879	3.979	2.692	3.720	2.506	3.460	2.319	3.149	2.095
	21	4.502	2.782	4.263	2.639	4.025	2.495	3.786	2.352	3.547	2.209	3.260	2.037
	22	4.506	2.499	4.288	2.399	4.070	2.299	3.852	2.198	3.634	2.098	3.372	1.978
	23	4.510	2.216	4.313	2.159	4.115	2.102	3.918	2.045	3.721	1.988	3.484	1.919
	24	4.514	1.933	4.337	1.919	4.161	1.905	3.984	1.891	3.807	1.877	3.595	1.860
30	20	4.498	3.560	4.239	3.373	3.979	3.187	3.720	3.000	3.460	2.814	3.149	2.590
	21	4.502	3.277	4.263	3.133	4.025	2.990	3.786	2.847	3.547	2.703	3.260	2.531
	22	4.506	2.994	4.288	2.893	4.070	2.793	3.852	2.693	3.634	2.593	3.372	2.472
	23	4.510	2.710	4.313	2.653	4.115	2.596	3.918	2.539	3.721	2.482	3.484	2.414
	24	4.514	2.427	4.337	2.413	4.161	2.399	3.984	2.386	3.807	2.372	3.595	2.355

Heating Mode

ID DB°C	Outdoor WB°C													
	-9		-6		-5		6		12		15		18	
	TC(kW)	SC(kW)	TC(kW)	SC(kW)	TC(kW)	SC(kW)	TC(kW)	SC(kW)	TC(kW)	SC(kW)	TC(kW)	SC(kW)	TC(kW)	SC(kW)
15	1.493	1.493	1.873	1.873	1.999	1.999	3.392	3.392	4.152	4.152	4.532	4.532	4.912	4.912
17	1.454	1.454	1.834	1.834	1.961	1.961	3.378	3.378	4.039	4.039	4.406	4.406	4.773	4.773
19	1.416	1.416	1.796	1.796	1.923	1.923	3.364	3.364	3.926	3.926	4.279	4.279	4.633	4.633
21	1.377	1.377	1.758	1.758	1.885	1.885	3.350	3.350	3.813	3.813	4.153	4.153	4.493	4.493
23	1.375	1.375	1.729	1.729	1.846	1.846	3.186	3.186	3.699	3.699	4.026	4.026	4.353	4.353
25	1.374	1.374	1.699	1.699	1.808	1.808	3.023	3.023	3.586	3.586	3.900	3.900	4.214	4.214
27	1.372	1.372	1.670	1.670	1.770	1.770	2.860	2.860	3.473	3.473	3.773	3.773	4.074	4.074
FROST REGION														

R22 Models (Heatpump)

Model : MCC 020CR / MLC 018CR
Cooling Mode

ID DB°C	ID WB°C	Outdoor DB°C											
		20		25		30		35		40		46	
		TC(kW)	SC(kW)	TC(kW)	SC(kW)	TC(kW)	SC(kW)	TC(kW)	SC(kW)	TC(kW)	SC(kW)	TC(kW)	SC(kW)
20	15	6.110	3.546	5.693	3.178	5.275	2.811	4.858	2.443	4.441	2.075	3.940	1.634
	16	6.252	3.215	5.827	2.886	5.403	2.557	4.978	2.227	4.554	1.898	4.044	1.503
24	16	6.252	4.441	5.827	4.112	5.403	3.782	4.978	3.453	4.554	3.124	4.044	2.729
	17	6.394	4.110	5.962	3.819	5.530	3.528	5.099	3.238	4.667	2.947	4.149	2.598
	18	6.535	3.778	6.097	3.526	5.658	3.274	5.219	3.022	4.780	2.770	4.253	2.468
	19	6.677	3.447	6.231	3.234	5.785	3.020	5.339	2.807	4.893	2.593	4.358	2.337
	20	6.820	3.116	6.376	2.938	5.932	2.760	5.489	2.583	5.045	2.405	4.512	2.192
28	18	6.535	5.004	6.097	4.752	5.658	4.500	5.219	4.248	4.780	3.996	4.253	3.694
	19	6.677	4.673	6.231	4.460	5.785	4.246	5.339	4.033	4.893	3.819	4.358	3.563
	20	6.820	4.342	6.376	4.164	5.932	3.986	5.489	3.809	5.045	3.631	4.512	3.418
	21	6.964	4.010	6.528	3.866	6.093	3.723	5.658	3.579	5.222	3.435	4.700	3.263
	22	7.107	3.678	6.680	3.569	6.254	3.459	5.827	3.349	5.400	3.239	4.888	3.107
	23	7.251	3.347	6.833	3.271	6.414	3.195	5.996	3.119	5.577	3.043	5.075	2.952
	24	7.395	3.015	6.985	2.973	6.575	2.931	6.165	2.889	5.755	2.847	5.263	2.797
30	20	6.820	4.955	6.376	4.777	5.932	4.599	5.489	4.422	5.045	4.244	4.512	4.031
	21	6.964	4.623	6.528	4.479	6.093	4.336	5.658	4.192	5.222	4.048	4.700	3.876
	22	7.107	4.291	6.680	4.181	6.254	4.072	5.827	3.962	5.400	3.852	4.888	3.720
	23	7.251	3.960	6.833	3.884	6.414	3.808	5.996	3.732	5.577	3.656	5.075	3.565
	24	7.395	3.628	6.985	3.586	6.575	3.544	6.165	3.502	5.755	3.460	5.263	3.410

Heating Mode

ID DB°C	Outdoor WB°C													
	-9		-6		-5		6		12		15		18	
	TC(kW)	SC(kW)	TC(kW)	SC(kW)	TC(kW)	SC(kW)	TC(kW)	SC(kW)	TC(kW)	SC(kW)	TC(kW)	SC(kW)	TC(kW)	SC(kW)
15	2.597	2.597	3.151	3.151	3.335	3.335	5.366	5.366	6.474	6.474	7.028	7.028	7.582	7.582
17	2.556	2.556	3.094	3.094	3.274	3.274	5.299	5.299	6.299	6.299	6.833	6.833	7.367	7.367
19	2.516	2.516	3.038	3.038	3.213	3.213	5.231	5.231	6.124	6.124	6.637	6.637	7.151	7.151
21	2.475	2.475	2.982	2.982	3.151	3.151	5.164	5.164	5.948	5.948	6.442	6.442	6.935	6.935
23	2.447	2.447	2.929	2.929	3.090	3.090	4.958	4.958	5.773	5.773	6.246	6.246	6.720	6.720
25	2.419	2.419	2.876	2.876	3.028	3.028	4.751	4.751	5.597	5.597	6.051	6.051	6.504	6.504
27	2.390	2.390	2.823	2.823	2.967	2.967	4.545	4.545	5.422	5.422	5.855	5.855	6.289	6.289
FROST REGION														

R22 Models (Heatpump)

Model : MCC 020CR / MLC 020CR
Cooling Mode

ID DB°C	ID WB°C	Outdoor DB°C											
		20		25		30		35		40		46	
		TC(kW)	SC(kW)	TC(kW)	SC(kW)	TC(kW)	SC(kW)	TC(kW)	SC(kW)	TC(kW)	SC(kW)	TC(kW)	SC(kW)
20	15	6.380	3.850	5.959	3.412	5.539	2.975	5.118	2.537	4.698	2.100	4.194	1.575
	16	6.491	3.642	6.077	3.195	5.662	2.749	5.247	2.302	4.833	1.856	4.336	1.320
24	16	6.491	4.949	6.077	4.502	5.662	4.056	5.247	3.609	4.833	3.162	4.336	2.627
	17	6.602	4.741	6.194	4.285	5.785	3.830	5.377	3.374	4.968	2.918	4.478	2.372
	18	6.714	4.533	6.311	4.069	5.908	3.604	5.506	3.139	5.103	2.675	4.620	2.117
	19	6.825	4.326	6.428	3.852	6.032	3.378	5.635	2.904	5.238	2.431	4.762	1.862
	20	6.937	4.121	6.548	3.663	6.159	3.206	5.770	2.748	5.381	2.290	4.915	1.741
28	18	6.714	5.840	6.311	5.375	5.908	4.911	5.506	4.446	5.103	3.981	4.620	3.424
	19	6.825	5.632	6.428	5.159	6.032	4.685	5.635	4.211	5.238	3.737	4.762	3.169
	20	6.937	5.428	6.548	4.970	6.159	4.512	5.770	4.055	5.381	3.597	4.915	3.048
	21	7.049	5.225	6.669	4.800	6.290	4.376	5.910	3.951	5.530	3.526	5.075	3.016
	22	7.161	5.022	6.790	4.631	6.420	4.239	6.050	3.847	5.679	3.455	5.235	2.984
	23	7.273	4.820	6.912	4.461	6.551	4.102	6.190	3.743	5.829	3.383	5.395	2.953
30	24	7.384	4.617	7.033	4.291	6.681	3.965	6.329	3.639	5.978	3.312	5.556	2.921
	20	6.937	6.081	6.548	5.624	6.159	5.166	5.770	4.708	5.381	4.250	4.915	3.701
	21	7.049	5.879	6.669	5.454	6.290	5.029	5.910	4.604	5.530	4.179	5.075	3.669
	22	7.161	5.676	6.790	5.284	6.420	4.892	6.050	4.500	5.679	4.108	5.235	3.638
	23	7.273	5.473	6.912	5.114	6.551	4.755	6.190	4.396	5.829	4.037	5.395	3.606
	24	7.384	5.271	7.033	4.944	6.681	4.618	6.329	4.292	5.978	3.966	5.556	3.574

Heating Mode

ID DB°C	Outdoor WB°C													
	-9		-6		-5		6		12		15		18	
	TC(kW)	SC(kW)	TC(kW)	SC(kW)	TC(kW)	SC(kW)	TC(kW)	SC(kW)	TC(kW)	SC(kW)	TC(kW)	SC(kW)	TC(kW)	SC(kW)
15	2.506	2.506	3.124	3.124	3.330	3.330	5.597	5.597	6.834	6.834	7.452	7.452	8.071	8.071
17	2.446	2.446	3.062	3.062	3.267	3.267	5.574	5.574	6.648	6.648	7.245	7.245	7.841	7.841
19	2.386	2.386	2.999	2.999	3.204	3.204	5.550	5.550	6.462	6.462	7.037	7.037	7.612	7.612
21	2.326	2.326	2.937	2.937	3.140	3.140	5.527	5.527	6.276	6.276	6.829	6.829	7.382	7.382
23	2.319	2.319	2.887	2.887	3.077	3.077	5.258	5.258	6.089	6.089	6.621	6.621	7.153	7.153
25	2.311	2.311	2.838	2.838	3.014	3.014	4.990	4.990	5.903	5.903	6.413	6.413	6.923	6.923
27	2.304	2.304	2.789	2.789	2.951	2.951	4.722	4.722	5.717	5.717	6.205	6.205	6.694	6.694
FROST REGION														

R22 Models (Heatpump)

Model : MCC 025CR / MLC 025BR

Cooling Mode

ID DB°C	ID WB°C	Outdoor DB°C											
		20		25		30		35		40		46	
		TC(kW)	SC(kW)	TC(kW)	SC(kW)	TC(kW)	SC(kW)	TC(kW)	SC(kW)	TC(kW)	SC(kW)	TC(kW)	SC(kW)
20	15	7.897	5.094	7.390	4.587	6.883	4.080	6.377	3.572	5.870	3.065	5.262	2.456
	16	7.913	4.608	7.451	4.144	6.988	3.681	6.525	3.217	6.063	2.753	5.507	2.196
24	16	7.913	5.951	7.451	5.488	6.988	5.024	6.525	4.560	6.063	4.096	5.507	3.539
	17	7.930	5.465	7.511	5.045	7.092	4.625	6.674	4.204	6.255	3.784	5.753	3.280
	18	7.946	4.979	7.571	4.602	7.197	4.225	6.822	3.849	6.448	3.472	5.998	3.020
	19	7.962	4.493	7.632	4.159	7.301	3.826	6.971	3.493	6.641	3.160	6.244	2.760
	20	7.977	4.008	7.676	3.731	7.374	3.454	7.073	3.177	6.772	2.900	6.411	2.567
28	18	7.946	6.322	7.571	5.945	7.197	5.569	6.822	5.192	6.448	4.815	5.998	4.363
	19	7.962	5.836	7.632	5.503	7.301	5.170	6.971	4.836	6.641	4.503	6.244	4.103
	20	7.977	5.351	7.676	5.074	7.374	4.797	7.073	4.520	6.772	4.243	6.411	3.910
	21	7.990	4.867	7.708	4.655	7.427	4.442	7.145	4.229	6.863	4.017	6.525	3.761
	22	8.003	4.384	7.741	4.235	7.479	4.087	7.217	3.939	6.954	3.790	6.640	3.612
	23	8.017	3.900	7.774	3.816	7.531	3.732	7.288	3.648	7.046	3.564	6.754	3.464
30	24	8.030	3.416	7.807	3.397	7.583	3.377	7.360	3.358	7.137	3.338	6.869	3.315
	20	7.977	6.023	7.676	5.746	7.374	5.468	7.073	5.191	6.772	4.914	6.411	4.582
	21	7.990	5.539	7.708	5.326	7.427	5.114	7.145	4.901	6.863	4.688	6.525	4.433
	22	8.003	5.055	7.741	4.907	7.479	4.759	7.217	4.610	6.954	4.462	6.640	4.284
	23	8.017	4.571	7.774	4.487	7.531	4.404	7.288	4.320	7.046	4.236	6.754	4.135
	24	8.030	4.088	7.807	4.068	7.583	4.049	7.360	4.029	7.137	4.010	6.869	3.986

Heating Mode

ID DB°C	Outdoor WB°C													
	-9		-6		-5		6		12		15		18	
	TC(kW)	SC(kW)	TC(kW)	SC(kW)	TC(kW)	SC(kW)	TC(kW)	SC(kW)	TC(kW)	SC(kW)	TC(kW)	SC(kW)	TC(kW)	SC(kW)
15	3.204	3.204	3.940	3.940	4.185	4.185	6.883	6.883	8.355	8.355	9.091	9.091	9.827	9.827
17	3.141	3.141	3.865	3.865	4.107	4.107	6.822	6.822	8.128	8.128	8.838	8.838	9.547	9.547
19	3.078	3.078	3.791	3.791	4.028	4.028	6.760	6.760	7.901	7.901	8.585	8.585	9.268	9.268
21	3.015	3.015	3.716	3.716	3.950	3.950	6.699	6.699	7.674	7.674	8.331	8.331	8.989	8.989
23	2.992	2.992	3.652	3.652	3.872	3.872	6.406	6.406	7.447	7.447	8.078	8.078	8.709	8.709
25	2.970	2.970	3.588	3.588	3.794	3.794	6.112	6.112	7.220	7.220	7.825	7.825	8.430	8.430
27	2.947	2.947	3.523	3.523	3.715	3.715	5.819	5.819	6.993	6.993	7.572	7.572	8.150	8.150
FROST REGION														

R22 Models (Heatpump)

Model : MCC 028CR / MLC 028CR
Cooling Mode

ID DB°C	ID WB°C	Outdoor DB°C											
		20		25		30		35		40		46	
		TC(kW)	SC(kW)	TC(kW)	SC(kW)	TC(kW)	SC(kW)	TC(kW)	SC(kW)	TC(kW)	SC(kW)	TC(kW)	SC(kW)
20	15	9.392	6.255	8.730	5.590	8.068	4.925	7.405	4.260	6.743	3.595	5.949	2.797
	16	9.493	5.930	8.848	5.280	8.204	4.630	7.559	3.980	6.914	3.330	6.141	2.550
24	16	9.493	7.523	8.848	6.873	8.204	6.223	7.559	5.573	6.914	4.923	6.141	4.143
	17	9.594	7.199	8.967	6.564	8.339	5.929	7.712	5.294	7.085	4.659	6.333	3.897
	18	9.694	6.875	9.085	6.255	8.475	5.635	7.866	5.015	7.256	4.394	6.525	3.650
	19	9.795	6.551	9.203	5.946	8.611	5.341	8.019	4.735	7.427	4.130	6.717	3.404
	20	9.897	6.229	9.328	5.653	8.758	5.078	8.189	4.502	7.620	3.927	6.937	3.236
	18	9.694	8.468	9.085	7.848	8.475	7.228	7.866	6.608	7.256	5.987	6.525	5.243
28	19	9.795	8.144	9.203	7.539	8.611	6.934	8.019	6.328	7.427	5.723	6.717	4.997
	20	9.897	7.822	9.328	7.246	8.758	6.671	8.189	6.095	7.620	5.520	6.937	4.829
	21	9.999	7.501	9.456	6.965	8.913	6.429	8.371	5.893	7.828	5.357	7.177	4.714
	22	10.100	7.180	9.584	6.684	9.068	6.187	8.552	5.691	8.036	5.195	7.416	4.600
	23	10.202	6.859	9.712	6.402	9.223	5.946	8.733	5.489	8.243	5.033	7.655	4.485
	24	10.304	6.538	9.841	6.121	9.377	5.704	8.914	5.287	8.451	4.870	7.895	4.370
30	20	9.897	8.618	9.328	8.043	8.758	7.467	8.189	6.892	7.620	6.316	6.937	5.626
	21	9.999	8.297	9.456	7.762	8.913	7.226	8.371	6.690	7.828	6.154	7.177	5.511
	22	10.100	7.976	9.584	7.480	9.068	6.984	8.552	6.488	8.036	5.992	7.416	5.396
	23	10.202	7.655	9.712	7.199	9.223	6.742	8.733	6.286	8.243	5.829	7.655	5.281
	24	10.304	7.334	9.841	6.917	9.377	6.500	8.914	6.084	8.451	5.667	7.895	5.167

Heating Mode

ID DB°C	Outdoor WB°C													
	-9		-6		-5		6		12		15		18	
	TC(kW)	SC(kW)	TC(kW)	SC(kW)	TC(kW)	SC(kW)	TC(kW)	SC(kW)	TC(kW)	SC(kW)	TC(kW)	SC(kW)	TC(kW)	SC(kW)
15	3.629	3.629	4.552	4.552	4.859	4.859	8.241	8.241	10.085	10.085	11.008	11.008	11.930	11.930
17	3.536	3.536	4.459	4.459	4.766	4.766	8.099	8.099	9.810	9.810	10.700	10.700	11.590	11.590
19	3.443	3.443	4.366	4.366	4.673	4.673	7.957	7.957	9.535	9.535	10.393	10.393	11.251	11.251
21	3.350	3.350	4.273	4.273	4.580	4.580	7.816	7.816	9.260	9.260	10.086	10.086	10.912	10.912
23	3.345	3.345	4.202	4.202	4.487	4.487	7.532	7.532	8.985	8.985	9.779	9.779	10.573	10.573
25	3.340	3.340	4.131	4.131	4.395	4.395	7.249	7.249	8.710	8.710	9.472	9.472	10.233	10.233
27	3.336	3.336	4.060	4.060	4.302	4.302	6.965	6.965	8.435	8.435	9.165	9.165	9.894	9.894
FROST REGION														

R22 Models (Heatpump)

Model : MCC 028CR / MLC 030CR

Cooling Mode

ID DB°C	ID WB°C	Outdoor DB°C															
		20		25		30		35		40		46		50		54	
		TC(kW)	SC(kW)	TC(kW)	SC(kW)	TC(kW)	SC(kW)	TC(kW)	SC(kW)	TC(kW)	SC(kW)	TC(kW)	SC(kW)	TC(kW)	SC(kW)	TC(kW)	SC(kW)
20	15	9.475	5.888	8.887	5.381	8.298	4.874	7.710	4.367	7.340	4.030	6.954	3.679	6.654	3.405	6.319	3.100
	16	10.104	5.667	9.402	5.121	8.700	4.574	7.998	4.028	7.614	3.707	7.214	3.372	6.902	3.112	6.555	2.822
24	16	10.104	7.254	9.402	6.707	8.700	6.161	7.998	5.614	7.614	5.294	7.214	4.959	6.902	4.699	6.555	4.408
	17	10.732	7.033	9.917	6.447	9.101	5.861	8.286	5.275	7.888	4.971	7.474	4.653	7.151	4.406	6.791	4.130
	18	11.361	6.811	10.432	6.186	9.503	5.561	8.574	4.935	8.162	4.647	7.733	4.347	7.399	4.113	7.027	3.852
	19	11.989	6.590	10.947	5.925	9.904	5.261	8.862	4.596	8.437	4.324	7.993	4.041	7.648	3.820	7.263	3.574
	20	12.624	6.374	11.517	5.711	10.410	5.047	9.303	4.384	8.857	4.122	8.392	3.849	8.029	3.637	7.625	3.400
28	18	11.361	8.398	10.432	7.773	9.503	7.148	8.574	6.522	8.162	6.234	7.733	5.934	7.399	5.700	7.027	5.439
	19	11.989	8.177	10.947	7.512	9.904	6.848	8.862	6.183	8.437	5.911	7.993	5.628	7.648	5.407	7.263	5.161
	20	12.624	7.961	11.517	7.297	10.410	6.634	9.303	5.971	8.857	5.709	8.392	5.436	8.029	5.224	7.625	4.987
	21	13.263	7.748	12.124	7.113	10.986	6.478	9.848	5.844	9.376	5.588	8.883	5.322	8.499	5.114	8.071	4.883
	22	13.901	7.534	12.732	6.928	11.562	6.322	10.392	5.716	9.894	5.467	9.374	5.207	8.969	5.004	8.518	4.778
	23	14.540	7.321	13.339	6.744	12.138	6.167	10.937	5.589	10.412	5.346	9.865	5.092	9.439	4.894	8.964	4.674
30	24	15.178	7.108	13.946	6.560	12.714	6.011	11.481	5.462	10.931	5.225	10.356	4.977	9.909	4.785	9.410	4.570
	20	12.624	8.754	11.517	8.091	10.410	7.428	9.303	6.764	8.857	6.503	8.392	6.230	8.029	6.017	7.625	5.780
	21	13.263	8.541	12.124	7.906	10.986	7.272	9.848	6.637	9.376	6.382	8.883	6.115	8.499	5.907	8.071	5.676
	22	13.901	8.328	12.732	7.722	11.562	7.116	10.392	6.510	9.894	6.261	9.374	6.000	8.969	5.798	8.518	5.572
	23	14.540	8.115	13.339	7.537	12.138	6.960	10.937	6.383	10.412	6.139	9.865	5.886	9.439	5.688	8.964	5.468
	24	15.178	7.902	13.946	7.353	12.714	6.804	11.481	6.256	10.931	6.018	10.356	5.771	9.909	5.578	9.410	5.363

HIGH AMBIENT

Heating Mode

ID DB°C	Outdoor WB°C													
	-9		-6		-5		6		12		15		18	
	TC(kW)	SC(kW)	TC(kW)	SC(kW)	TC(kW)	SC(kW)	TC(kW)	SC(kW)	TC(kW)	SC(kW)	TC(kW)	SC(kW)	TC(kW)	SC(kW)
15	3.942	3.942	4.829	4.829	5.125	5.125	8.381	8.381	10.157	10.157	11.045	11.045	11.933	11.933
17	3.868	3.868	4.740	4.740	5.030	5.030	8.379	8.379	9.882	9.882	10.738	10.738	11.594	11.594
19	3.795	3.795	4.650	4.650	4.935	4.935	8.376	8.376	9.606	9.606	10.430	10.430	11.255	11.255
21	3.722	3.722	4.560	4.560	4.839	4.839	8.374	8.374	9.330	9.330	10.123	10.123	10.915	10.915
23	3.690	3.690	4.480	4.480	4.744	4.744	7.941	7.941	9.054	9.054	9.815	9.815	10.576	10.576
25	3.658	3.658	4.401	4.401	4.648	4.648	7.508	7.508	8.779	8.779	9.508	9.508	10.237	10.237
27	3.627	3.627	4.321	4.321	4.553	4.553	7.076	7.076	8.503	8.503	9.200	9.200	9.897	9.897

FROST REGION

R22 Models (Heatpump)

Model : MCC 038CR / MLC 035CR
Cooling Mode

ID DB°C	ID WB°C	Outdoor DB°C											
		20		25		30		35		40		46	
		TC(kW)	SC(kW)	TC(kW)	SC(kW)	TC(kW)	SC(kW)	TC(kW)	SC(kW)	TC(kW)	SC(kW)	TC(kW)	SC(kW)
20	15	13.166	7.818	12.078	6.774	10.989	5.730	9.900	4.686	8.812	3.642	7.505	2.389
	16	13.389	7.410	12.270	6.373	11.150	5.336	10.031	4.299	8.911	3.262	7.568	2.017
24	16	13.389	10.168	12.270	9.130	11.150	8.093	10.031	7.056	8.911	6.019	7.568	4.774
	17	13.612	9.760	12.462	8.730	11.311	7.700	10.161	6.669	9.011	5.639	7.630	4.403
	18	13.835	9.352	12.654	8.329	11.472	7.306	10.291	6.283	9.110	5.259	7.693	4.032
	19	14.057	8.944	12.846	7.928	11.634	6.912	10.422	5.896	9.210	4.880	7.756	3.660
	20	14.287	8.541	13.097	7.568	11.907	6.595	10.718	5.622	9.528	4.649	8.100	3.481
28	18	13.835	12.109	12.654	11.086	11.472	10.063	10.291	9.040	9.110	8.017	7.693	6.789
	19	14.057	11.702	12.846	10.686	11.634	9.669	10.422	8.653	9.210	7.637	7.756	6.417
	20	14.287	11.298	13.097	10.325	11.907	9.352	10.718	8.379	9.528	7.406	8.100	6.238
	21	14.520	10.898	13.388	9.992	12.256	9.086	11.124	8.180	9.992	7.275	8.634	6.188
	22	14.753	10.497	13.679	9.659	12.605	8.820	11.530	7.982	10.456	7.143	9.167	6.137
	23	14.987	10.097	13.970	9.325	12.953	8.554	11.937	7.783	10.920	7.012	9.700	6.086
	24	15.220	9.696	14.261	8.992	13.302	8.288	12.343	7.584	11.384	6.880	10.233	6.035
	20	14.287	12.677	13.097	11.704	11.907	10.731	10.718	9.758	9.528	8.785	8.100	7.617
30	21	14.520	12.276	13.388	11.371	12.256	10.465	11.124	9.559	9.992	8.653	8.634	7.566
	22	14.753	11.876	13.679	11.037	12.605	10.199	11.530	9.360	10.456	8.522	9.167	7.515
	23	14.987	11.475	13.970	10.704	12.953	9.933	11.937	9.162	10.920	8.390	9.700	7.465
	24	15.220	11.075	14.261	10.371	13.302	9.667	12.343	8.963	11.384	8.259	10.233	7.414

Heating Mode

ID DB°C	Outdoor WB°C													
	-9		-6		-5		6		12		15		18	
	TC(kW)	SC(kW)	TC(kW)	SC(kW)	TC(kW)	SC(kW)	TC(kW)	SC(kW)	TC(kW)	SC(kW)	TC(kW)	SC(kW)	TC(kW)	SC(kW)
15	4.741	4.741	5.949	5.949	6.352	6.352	10.782	10.782	13.198	13.198	14.406	14.406	15.614	15.614
17	4.618	4.618	5.827	5.827	6.230	6.230	10.537	10.537	12.838	12.838	14.004	14.004	15.170	15.170
19	4.496	4.496	5.706	5.706	6.109	6.109	10.293	10.293	12.478	12.478	13.602	13.602	14.726	14.726
21	4.373	4.373	5.584	5.584	5.987	5.987	10.049	10.049	12.118	12.118	13.200	13.200	14.282	14.282
23	4.368	4.368	5.491	5.491	5.866	5.866	9.740	9.740	11.758	11.758	12.798	12.798	13.838	13.838
25	4.363	4.363	5.399	5.399	5.744	5.744	9.431	9.431	11.398	11.398	12.396	12.396	13.394	13.394
27	4.358	4.358	5.306	5.306	5.623	5.623	9.122	9.122	11.038	11.038	11.994	11.994	12.949	12.949
FROST REGION														

R22 Models (Heatpump)

Model : MCC 038CR / MLC 040CR
Cooling Mode

ID DB°C	ID WB°C	Outdoor DB°C															
		20		25		30		35		40		46		50		54	
		TC(kW)	SC(kW)	TC(kW)	SC(kW)	TC(kW)	SC(kW)	TC(kW)	SC(kW)	TC(kW)	SC(kW)	TC(kW)	SC(kW)	TC(kW)	SC(kW)	TC(kW)	SC(kW)
20	15	13.481	7.432	12.443	6.570	11.405	5.707	10.368	4.844	9.494	4.012	8.618	3.178	8.290	2.866	8.169	2.751
	16	13.675	6.732	12.631	6.020	11.587	5.307	10.543	4.595	9.654	3.784	8.763	2.970	8.430	2.667	8.307	2.554
24	16	13.675	9.734	12.631	9.021	11.587	8.309	10.543	7.596	9.654	6.786	8.763	5.972	8.430	5.668	8.307	5.556
	17	13.869	9.034	12.818	8.471	11.768	7.909	10.717	7.347	9.814	6.557	8.908	5.765	8.570	5.469	8.444	5.359
	18	14.063	8.334	13.006	7.921	11.949	7.509	10.892	7.097	9.975	6.328	9.054	5.557	8.710	5.269	8.582	5.162
	19	14.257	7.633	13.194	7.371	12.130	7.109	11.067	6.847	10.135	6.100	9.199	5.350	8.850	5.069	8.720	4.965
28	20	14.455	6.925	13.418	6.745	12.382	6.566	11.345	6.386	10.389	5.677	9.430	4.966	9.072	4.700	8.939	4.602
	18	14.063	11.335	13.006	10.923	11.949	10.511	10.892	10.099	9.975	9.330	9.054	8.559	8.710	8.271	8.582	8.164
	19	14.257	10.635	13.194	10.373	12.130	10.111	11.067	9.849	10.135	9.101	9.199	8.351	8.850	8.071	8.720	7.967
	20	14.455	9.927	13.418	9.747	12.382	9.567	11.345	9.388	10.389	8.679	9.430	7.968	9.072	7.702	8.939	7.604
	21	14.655	9.213	13.668	9.070	12.680	8.928	11.692	8.785	10.707	8.127	9.718	7.467	9.349	7.220	9.212	7.129
	22	14.856	8.499	13.917	8.394	12.978	8.288	12.039	8.182	11.024	7.575	10.007	6.966	9.627	6.738	9.486	6.654
	23	15.056	7.785	14.166	7.717	13.276	7.648	12.386	7.579	11.342	7.023	10.295	6.465	9.904	6.256	9.759	6.179
	24	15.257	7.072	14.415	7.040	13.574	7.008	12.732	6.976	11.660	6.471	10.583	5.963	10.181	5.774	10.032	5.704
30	20	14.455	11.428	13.418	11.248	12.382	11.068	11.345	10.888	10.389	10.180	9.469	9.469	9.203	9.203	9.104	9.104
	21	14.655	10.714	13.668	10.571	12.680	10.428	11.692	10.286	10.707	9.628	9.718	8.968	9.349	8.721	9.212	8.630
	22	14.856	10.000	13.917	9.894	12.978	9.789	12.039	9.683	11.024	9.076	10.007	8.466	9.627	8.239	9.486	8.155
	23	15.056	9.286	14.166	9.218	13.276	9.149	12.386	9.080	11.342	8.524	10.295	7.965	9.904	7.757	9.759	7.680
	24	15.257	8.573	14.415	8.541	13.574	8.509	12.732	8.477	11.660	7.972	10.583	7.464	10.181	7.275	10.032	7.205

HIGH AMBIENT

Heating Mode

ID DB°C	Outdoor WB°C													
	-9		-6		-5		6		12		15		18	
	TC(kW)	SC(kW)	TC(kW)	SC(kW)	TC(kW)	SC(kW)	TC(kW)	SC(kW)	TC(kW)	SC(kW)	TC(kW)	SC(kW)	TC(kW)	SC(kW)
15	6.363	6.363	7.519	7.519	7.904	7.904	12.142	12.142	14.454	14.454	15.610	15.610	16.766	16.766
17	6.313	6.313	7.401	7.401	7.763	7.763	11.856	11.856	14.065	14.065	15.177	15.177	16.289	16.289
19	6.263	6.263	7.283	7.283	7.622	7.622	11.570	11.570	13.676	13.676	14.745	14.745	15.813	15.813
21	6.213	6.213	7.165	7.165	7.482	7.482	11.284	11.284	13.287	13.287	14.312	14.312	15.336	15.336
23	6.097	6.097	7.030	7.030	7.341	7.341	10.966	10.966	12.898	12.898	13.879	13.879	14.860	14.860
25	5.980	5.980	6.895	6.895	7.200	7.200	10.649	10.649	12.509	12.509	13.446	13.446	14.383	14.383
27	5.864	5.864	6.761	6.761	7.060	7.060	10.332	10.332	12.120	12.120	13.013	13.013	13.907	13.907

FROST REGION

R22 Models (Heatpump)

Model : MCC 030CR / MLC 028CR
Cooling Mode

ID DB°C	ID WB°C	Outdoor DB°C											
		20		25		30		35		40		46	
		TC(kW)	SC(kW)	TC(kW)	SC(kW)	TC(kW)	SC(kW)	TC(kW)	SC(kW)	TC(kW)	SC(kW)	TC(kW)	SC(kW)
20	15	9.703	6.460	9.024	5.773	8.345	5.086	7.666	4.399	6.987	3.711	6.172	2.887
	16	9.810	6.128	9.150	5.452	8.489	4.775	7.828	4.098	7.168	3.422	6.375	2.610
24	16	9.810	7.774	9.150	7.098	8.489	6.421	7.828	5.744	7.168	5.068	6.375	4.256
	17	9.918	7.442	9.275	6.776	8.633	6.110	7.991	5.444	7.348	4.778	6.577	3.978
	18	10.025	7.110	9.401	6.455	8.777	5.799	8.153	5.144	7.529	4.488	6.780	3.701
	19	10.133	6.778	9.527	6.133	8.921	5.488	8.315	4.843	7.709	4.198	6.982	3.424
28	20	10.241	6.449	9.658	5.834	9.075	5.219	8.492	4.604	7.909	3.989	7.210	3.251
	18	10.025	8.756	9.401	8.101	8.777	7.445	8.153	6.789	7.529	6.134	6.780	5.347
	19	10.133	8.424	9.527	7.779	8.921	7.134	8.315	6.489	7.709	5.844	6.982	5.070
	20	10.241	8.095	9.658	7.480	9.075	6.865	8.492	6.250	7.909	5.635	7.210	4.897
	21	10.349	7.766	9.792	7.194	9.236	6.622	8.679	6.050	8.122	5.478	7.454	4.792
	22	10.458	7.438	9.927	6.909	9.396	6.380	8.866	5.851	8.335	5.322	7.698	4.688
	23	10.566	7.110	10.061	6.624	9.557	6.138	9.053	5.652	8.548	5.166	7.943	4.583
30	24	10.674	6.782	10.196	6.339	9.718	5.896	9.239	5.453	8.761	5.010	8.187	4.479
	20	10.241	8.917	9.658	8.302	9.075	7.687	8.492	7.072	7.909	6.457	7.210	5.719
	21	10.349	8.589	9.792	8.017	9.236	7.445	8.679	6.873	8.122	6.301	7.454	5.615
	22	10.458	8.261	9.927	7.732	9.396	7.203	8.866	6.674	8.335	6.145	7.698	5.511
	23	10.566	7.933	10.061	7.447	9.557	6.961	9.053	6.475	8.548	5.999	7.943	5.406
	24	10.674	7.605	10.196	7.162	9.718	6.719	9.239	6.276	8.761	5.833	8.187	5.302

Heating Mode

ID DB°C	Outdoor WB°C													
	-9		-6		-5		6		12		15		18	
	TC(kW)	SC(kW)	TC(kW)	SC(kW)	TC(kW)	SC(kW)	TC(kW)	SC(kW)	TC(kW)	SC(kW)	TC(kW)	SC(kW)	TC(kW)	SC(kW)
15	3.859	3.859	4.849	4.849	5.179	5.179	8.810	8.810	10.791	10.791	11.781	11.781	12.772	12.772
17	3.757	3.757	4.749	4.749	5.080	5.080	8.572	8.572	10.497	10.497	11.453	11.453	12.408	12.408
19	3.656	3.656	4.650	4.650	4.981	4.981	8.333	8.333	10.202	10.202	11.124	11.124	12.045	12.045
21	3.554	3.554	4.550	4.550	4.882	4.882	8.095	8.095	9.908	9.908	10.795	10.795	11.682	11.682
23	3.552	3.552	4.475	4.475	4.782	4.782	7.883	7.883	9.614	9.614	10.466	10.466	11.319	11.319
25	3.549	3.549	4.400	4.400	4.683	4.683	7.671	7.671	9.319	9.319	10.137	10.137	10.955	10.955
27	3.547	3.547	4.325	4.325	4.584	4.584	7.459	7.459	9.025	9.025	9.808	9.808	10.592	10.592
FROST REGION														

R22 Models (Heatpump)

Model : MCC 030CR / MLC 030CR Cooling Mode

ID DB°C	ID WB°C	Outdoor DB°C															
		20		25		30		35		40		46		50		54	
		TC(kW)	SC(kW)	TC(kW)	SC(kW)	TC(kW)	SC(kW)	TC(kW)	SC(kW)	TC(kW)	SC(kW)	TC(kW)	SC(kW)	TC(kW)	SC(kW)	TC(kW)	SC(kW)
20	15	9.076	5.773	8.573	5.349	8.070	4.924	7.567	4.500	7.204	4.153	6.826	3.791	6.531	3.509	6.202	3.195
	16	9.466	5.645	8.926	5.255	8.386	4.865	7.846	4.474	7.470	4.129	7.077	3.768	6.771	3.487	6.430	3.174
24	16	9.466	7.278	8.926	6.888	8.386	6.497	7.846	6.107	7.470	5.762	7.077	5.401	6.771	5.120	6.430	4.807
	17	9.856	7.149	9.279	6.794	8.702	6.438	8.124	6.082	7.735	5.738	7.328	5.378	7.012	5.098	6.659	4.786
	18	10.246	7.021	9.632	6.700	9.017	6.378	8.403	6.057	8.000	5.714	7.580	5.356	7.252	5.077	6.887	4.766
	19	10.636	6.893	9.985	6.606	9.333	6.319	8.682	6.032	8.266	5.690	7.831	5.333	7.493	5.055	7.116	4.745
28	20	11.027	6.759	10.347	6.459	9.668	6.159	8.988	5.859	8.557	5.525	8.107	5.176	7.757	4.905	7.367	4.603
	18	10.246	8.654	9.632	8.333	9.017	8.011	8.403	7.690	8.000	7.347	7.580	6.988	7.252	6.709	6.887	6.398
	19	10.636	8.526	9.985	8.239	9.333	7.952	8.682	7.665	8.266	7.323	7.831	6.966	7.493	6.688	7.116	6.378
	20	11.027	8.392	10.347	8.091	9.668	7.791	8.988	7.491	8.557	7.157	8.107	6.809	7.757	6.538	7.367	6.236
	21	11.418	8.254	10.716	7.909	10.014	7.564	9.312	7.219	8.865	6.898	8.399	6.563	8.037	6.303	7.632	6.012
	22	11.810	8.116	11.085	7.726	10.361	7.336	9.636	6.946	9.174	6.639	8.692	6.318	8.316	6.068	7.898	5.789
30	23	12.202	7.978	11.455	7.543	10.707	7.109	9.960	6.674	9.483	6.379	8.984	6.072	8.596	5.833	8.164	5.566
	24	12.593	7.840	11.824	7.361	11.054	6.881	10.284	6.402	9.791	6.120	9.277	5.826	8.876	5.598	8.429	5.342
	20	11.027	9.208	10.347	8.908	9.668	8.608	8.988	8.308	8.557	7.974	8.107	7.626	7.757	7.354	7.367	7.052
	21	11.418	9.070	10.716	8.725	10.014	8.380	9.312	8.035	8.865	7.714	8.399	7.380	8.037	7.119	7.632	6.829
30	22	11.810	8.932	11.085	8.542	10.361	8.153	9.636	7.763	9.174	7.455	8.692	7.134	8.316	6.884	7.898	6.605
	23	12.202	8.794	11.455	8.360	10.707	7.925	9.960	7.490	9.483	7.196	8.984	6.888	8.596	6.649	8.164	6.382
	24	12.593	8.657	11.824	8.177	11.054	7.697	10.284	7.218	9.791	6.936	9.277	6.643	8.876	6.414	8.429	6.159

HIGH AMBIENT

Heating Mode

ID DB°C	Outdoor WB°C													
	-9		-6		-5		6		12		15		18	
	TC(kW)	SC(kW)	TC(kW)	SC(kW)	TC(kW)	SC(kW)	TC(kW)	SC(kW)	TC(kW)	SC(kW)	TC(kW)	SC(kW)	TC(kW)	SC(kW)
15	5.582	5.582	6.437	6.437	6.722	6.722	9.858	9.858	11.569	11.569	12.424	12.424	13.279	13.279
17	5.577	5.577	6.349	6.349	6.606	6.606	9.503	9.503	11.259	11.259	12.081	12.081	12.902	12.902
19	5.573	5.573	6.261	6.261	6.491	6.491	9.148	9.148	10.950	10.950	11.737	11.737	12.524	12.524
21	5.569	5.569	6.173	6.173	6.375	6.375	8.792	8.792	10.641	10.641	11.394	11.394	12.147	12.147
23	5.429	5.429	6.051	6.051	6.259	6.259	8.672	8.672	10.332	10.332	11.051	11.051	11.770	11.770
25	5.289	5.289	5.930	5.930	6.143	6.143	8.551	8.551	10.023	10.023	10.708	10.708	11.392	11.392
27	5.149	5.149	5.808	5.808	6.027	6.027	8.431	8.431	9.714	9.714	10.364	10.364	11.015	11.015

FROST REGION

R22 Models (Heatpump)

Model : MCC 040CR / MLC 035CR
Cooling Mode

ID DB°C	ID WB°C	Outdoor DB°C											
		20		25		30		35		40		46	
		TC(kW)	SC(kW)	TC(kW)	SC(kW)	TC(kW)	SC(kW)	TC(kW)	SC(kW)	TC(kW)	SC(kW)	TC(kW)	SC(kW)
20	15	11.852	7.506	11.013	6.689	10.173	5.872	9.333	5.055	8.493	4.238	7.486	3.258
	16	11.981	6.975	11.163	6.200	10.344	5.425	9.525	4.649	8.706	3.874	7.723	2.943
24	16	11.981	9.136	11.163	8.360	10.344	7.585	9.525	6.810	8.706	6.034	7.723	5.104
	17	12.111	8.605	11.312	7.871	10.514	7.137	9.716	6.403	8.918	5.669	7.960	4.789
	18	12.240	8.075	11.462	7.382	10.685	6.690	9.908	5.997	9.130	5.305	8.197	4.474
	19	12.369	7.544	11.612	6.893	10.856	6.242	10.099	5.591	9.343	4.940	8.435	4.159
	20	12.499	7.016	11.771	6.421	11.043	5.826	10.315	5.232	9.587	4.637	8.714	3.924
28	18	12.240	10.235	11.462	9.543	10.685	8.850	9.908	8.158	9.130	7.465	8.197	6.634
	19	12.369	9.705	11.612	9.054	10.856	8.403	10.099	7.751	9.343	7.100	8.435	6.319
	20	12.499	9.176	11.771	8.581	11.043	7.987	10.315	7.392	9.587	6.798	8.714	6.084
	21	12.629	8.649	11.935	8.120	11.241	7.592	10.547	7.064	9.853	6.536	9.021	5.903
	22	12.760	8.121	12.100	7.659	11.440	7.198	10.780	6.736	10.120	6.275	9.328	5.721
	23	12.891	7.594	12.264	7.198	11.638	6.803	11.012	6.408	10.386	6.013	9.635	5.539
	24	13.021	7.066	12.429	6.738	11.837	6.409	11.244	6.080	10.652	5.752	9.942	5.358
30	20	12.499	10.256	11.771	9.662	11.043	9.067	10.315	8.472	9.587	7.878	8.714	7.164
	21	12.629	9.729	11.935	9.201	11.241	8.673	10.547	8.144	9.853	7.616	9.021	6.983
	22	12.760	9.201	12.100	8.740	11.440	8.278	10.780	7.817	10.120	7.355	9.328	6.801
	23	12.891	8.674	12.264	8.279	11.638	7.884	11.012	7.489	10.386	7.094	9.635	6.619
	24	13.021	8.146	12.429	7.818	11.837	7.489	11.244	7.161	10.652	6.832	9.942	6.438

Heating Mode

ID DB°C	Outdoor WB°C													
	-9		-6		-5		6		12		15		18	
	TC(kW)	SC(kW)	TC(kW)	SC(kW)	TC(kW)	SC(kW)	TC(kW)	SC(kW)	TC(kW)	SC(kW)	TC(kW)	SC(kW)	TC(kW)	SC(kW)
15	4.651	4.651	5.850	5.850	6.249	6.249	10.644	10.644	13.041	13.041	14.239	14.239	15.438	15.438
17	4.527	4.527	5.729	5.729	6.129	6.129	10.445	10.445	12.685	12.685	13.842	13.842	14.999	14.999
19	4.404	4.404	5.608	5.608	6.009	6.009	10.247	10.247	12.329	12.329	13.445	13.445	14.560	14.560
21	4.280	4.280	5.487	5.487	5.890	5.890	10.049	10.049	11.974	11.974	13.047	13.047	14.121	14.121
23	4.278	4.278	5.397	5.397	5.770	5.770	9.698	9.698	11.618	11.618	12.650	12.650	13.682	13.682
25	4.276	4.276	5.306	5.306	5.650	5.650	9.347	9.347	11.262	11.262	12.252	12.252	13.243	13.243
27	4.274	4.274	5.216	5.216	5.530	5.530	8.997	8.997	10.906	10.906	11.855	11.855	12.804	12.804
FROST REGION														

R22 Models (Heatpump)

Model : MCC 040CR / MLC 040CR Cooling Mode

ID DB°C	ID WB°C	Outdoor DB°C															
		20		25		30		35		40		46		50		54	
		TC(kW)	SC(kW)	TC(kW)	SC(kW)	TC(kW)	SC(kW)	TC(kW)	SC(kW)	TC(kW)	SC(kW)	TC(kW)	SC(kW)	TC(kW)	SC(kW)	TC(kW)	SC(kW)
20	15	12.360	8.239	11.670	7.643	10.979	7.047	10.288	6.451	9.422	5.635	8.552	4.817	8.227	4.511	8.107	4.398
	16	12.579	7.644	11.924	7.170	11.269	6.697	10.615	6.223	9.720	5.426	8.823	4.627	8.488	4.329	8.363	4.218
24	16	12.579	9.572	11.924	9.099	11.269	8.625	10.615	8.151	9.720	7.355	8.823	6.555	8.488	6.257	8.363	6.146
	17	12.797	8.978	12.179	8.626	11.560	8.275	10.941	7.923	10.019	7.146	9.094	6.366	8.749	6.075	8.620	5.967
	18	13.016	8.384	12.433	8.154	11.850	7.924	11.267	7.695	10.317	6.937	9.365	6.176	9.009	5.892	8.877	5.787
	19	13.235	7.789	12.687	7.682	12.140	7.574	11.593	7.467	10.616	6.728	9.636	5.987	9.270	5.710	9.134	5.607
	20	13.450	7.186	12.915	7.130	12.380	7.075	11.846	7.019	10.847	6.318	9.846	5.615	9.472	5.352	9.333	5.254
28	18	13.016	10.312	12.433	10.082	11.850	9.853	11.267	9.623	10.317	8.865	9.365	8.105	9.009	7.821	8.877	7.715
	19	13.235	9.717	12.687	9.610	12.140	9.502	11.593	9.395	10.616	8.656	9.636	7.915	9.270	7.638	9.134	7.535
	20	13.450	9.114	12.915	9.059	12.380	9.003	11.846	8.947	10.847	8.246	9.846	7.543	9.472	7.280	9.333	7.183
	21	13.664	8.506	13.126	8.455	12.588	8.404	12.049	8.354	11.034	7.702	10.015	7.049	9.635	6.805	9.494	6.715
	22	13.878	7.897	13.336	7.851	12.795	7.806	12.253	7.760	11.220	7.159	10.185	6.556	9.798	6.330	9.654	6.247
	23	14.092	7.289	13.547	7.248	13.002	7.207	12.457	7.166	11.407	6.615	10.354	6.062	9.961	5.856	9.815	5.779
	24	14.306	6.680	13.757	6.644	13.209	6.608	12.660	6.572	11.593	6.071	10.523	5.568	10.124	5.381	9.975	5.311
30	20	13.450	10.079	12.915	10.023	12.380	9.967	11.846	9.912	10.847	9.210	9.846	8.507	9.472	8.244	9.333	8.147
	21	13.664	9.470	13.126	9.419	12.588	9.368	12.049	9.318	11.034	8.667	10.015	8.013	9.635	7.770	9.494	7.679
	22	13.878	8.862	13.336	8.816	12.795	8.770	12.253	8.724	11.220	8.123	10.185	7.520	9.798	7.295	9.654	7.211
	23	14.092	8.253	13.547	8.212	13.002	8.171	12.457	8.130	11.407	7.579	10.354	7.026	9.961	6.820	9.815	6.743
	24	14.306	7.644	13.757	7.608	13.209	7.572	12.660	7.536	11.593	7.035	10.523	6.533	10.124	6.345	9.975	6.275

HIGH AMBIENT

Heating Mode

ID DB°C	Outdoor WB°C													
	-9		-6		-5		6		12		15		18	
	TC(kW)	SC(kW)	TC(kW)	SC(kW)	TC(kW)	SC(kW)	TC(kW)	SC(kW)	TC(kW)	SC(kW)	TC(kW)	SC(kW)	TC(kW)	SC(kW)
15	6.607	6.607	7.814	7.814	8.216	8.216	12.639	12.639	15.052	15.052	16.258	16.258	17.464	17.464
17	6.554	6.554	7.691	7.691	8.069	8.069	12.334	12.334	14.647	14.647	15.807	15.807	16.968	16.968
19	6.501	6.501	7.567	7.567	7.923	7.923	12.029	12.029	14.241	14.241	15.356	15.356	16.471	16.471
21	6.448	6.448	7.444	7.444	7.776	7.776	11.723	11.723	13.836	13.836	14.906	14.906	15.975	15.975
23	6.328	6.328	7.305	7.305	7.630	7.630	11.400	11.400	13.431	13.431	14.455	14.455	15.479	15.479
25	6.209	6.209	7.165	7.165	7.484	7.484	11.078	11.078	13.026	13.026	14.004	14.004	14.982	14.982
27	6.089	6.089	7.025	7.025	7.337	7.337	10.755	10.755	12.621	12.621	13.553	13.553	14.486	14.486

FROST REGION

R22 Models (Heatpump)

Model : MCC 050CR / MLC 050CR Cooling Mode

ID DB°C	ID WB°C	Outdoor DB°C															
		20		25		30		35		40		46		50		54	
		TC(kW)	SC(kW)	TC(kW)	SC(kW)	TC(kW)	SC(kW)	TC(kW)	SC(kW)	TC(kW)	SC(kW)	TC(kW)	SC(kW)	TC(kW)	SC(kW)	TC(kW)	SC(kW)
20	15	15.221	9.369	14.373	8.621	13.526	7.873	12.679	7.125	11.946	6.438	11.274	5.808	10.882	5.440	10.535	5.115
	16	15.773	8.931	14.891	8.239	14.009	7.547	13.128	6.854	12.369	6.183	11.673	5.567	11.267	5.208	10.908	4.890
24	16	15.773	11.775	14.891	11.082	14.009	10.390	13.128	9.698	12.369	9.026	11.673	8.411	11.267	8.051	10.908	7.733
	17	16.326	11.337	15.409	10.701	14.493	10.064	13.577	9.427	12.792	8.771	12.073	8.170	11.653	7.819	11.281	7.508
	18	16.878	10.900	15.927	10.319	14.976	9.738	14.026	9.157	13.215	8.517	12.472	7.930	12.038	7.587	11.654	7.284
	19	17.431	10.462	16.445	9.937	15.460	9.412	14.475	8.886	13.638	8.262	12.871	7.689	12.423	7.355	12.027	7.059
28	20	17.984	10.020	16.967	9.509	15.951	8.998	14.935	8.488	14.071	7.886	13.280	7.335	12.818	7.013	12.409	6.728
	18	16.878	13.743	15.927	13.162	14.976	12.581	14.026	12.000	13.215	11.360	12.472	10.773	12.038	10.431	11.654	10.127
	19	17.431	13.305	16.445	12.780	15.460	12.255	14.475	11.730	13.638	11.105	12.871	10.533	12.423	10.199	12.027	9.902
	20	17.984	12.863	16.967	12.352	15.951	11.842	14.935	11.331	14.071	10.729	13.280	10.178	12.818	9.856	12.409	9.571
	21	18.537	12.417	17.492	11.894	16.447	11.370	15.402	10.846	14.512	10.273	13.696	9.747	13.219	9.440	12.797	9.168
	22	19.090	11.971	18.017	11.435	16.943	10.898	15.870	10.362	14.952	9.816	14.111	9.316	13.621	9.024	13.186	8.766
	23	19.643	11.525	18.541	10.976	17.439	10.427	16.337	9.877	15.393	9.360	14.527	8.885	14.022	8.609	13.574	8.363
	24	20.196	11.080	19.066	10.517	17.935	9.955	16.805	9.393	15.833	8.903	14.943	8.454	14.423	8.193	13.963	7.961
30	20	17.984	14.285	16.967	13.774	15.951	13.263	14.935	12.753	14.071	12.151	13.280	11.600	12.818	11.278	12.409	10.993
	21	18.537	13.839	17.492	13.315	16.447	12.792	15.402	12.268	14.512	11.694	13.696	11.169	13.219	10.862	12.797	10.590
	22	19.090	13.393	18.017	12.856	16.943	12.320	15.870	11.783	14.952	11.238	14.111	10.738	13.621	10.446	13.186	10.187
	23	19.643	12.947	18.541	12.398	17.439	11.848	16.337	11.299	15.393	10.781	14.527	10.307	14.022	10.030	13.574	9.785
	24	20.196	12.501	19.066	11.939	17.935	11.377	16.805	10.814	15.833	10.325	14.943	9.876	14.423	9.614	13.963	9.382

HIGH AMBIENT

Heating Mode

ID DB°C	Outdoor WB°C													
	-9		-6		-5		6		12		15		18	
	TC(kW)	SC(kW)	TC(kW)	SC(kW)	TC(kW)	SC(kW)	TC(kW)	SC(kW)	TC(kW)	SC(kW)	TC(kW)	SC(kW)	TC(kW)	SC(kW)
15	8.814	8.814	10.164	10.164	10.614	10.614	15.565	15.565	18.266	18.266	19.617	19.617	20.967	20.967
17	8.807	8.807	10.025	10.025	10.431	10.431	15.555	15.555	17.778	17.778	19.075	19.075	20.371	20.371
19	8.799	8.799	9.886	9.886	10.248	10.248	15.544	15.544	17.290	17.290	18.533	18.533	19.775	19.775
21	8.792	8.792	9.747	9.747	10.065	10.065	15.533	15.533	16.802	16.802	17.991	17.991	19.180	19.180
23	8.572	8.572	9.555	9.555	9.883	9.883	14.764	14.764	16.314	16.314	17.449	17.449	18.584	18.584
25	8.351	8.351	9.363	9.363	9.700	9.700	13.994	13.994	15.826	15.826	16.907	16.907	17.988	17.988
27	8.131	8.131	9.170	9.170	9.517	9.517	13.225	13.225	15.338	15.338	16.365	16.365	17.392	17.392

FROST REGION

R22 Models (Heatpump)

Model : MCC 060CR / MLC 061CR
Cooling Mode

ID DB°C	ID WB°C	Outdoor DB°C											
		20		25		30		35		40		46	
		TC(kW)	SC(kW)	TC(kW)	SC(kW)	TC(kW)	SC(kW)	TC(kW)	SC(kW)	TC(kW)	SC(kW)	TC(kW)	SC(kW)
20	15	16.974	11.071	16.021	10.210	15.068	9.348	14.115	8.487	13.161	7.626	12.018	6.592
	16	17.754	10.856	16.715	9.992	15.676	9.127	14.636	8.263	13.597	7.398	12.350	6.361
24	16	17.754	13.722	16.715	12.857	15.676	11.993	14.636	11.128	13.597	10.264	12.350	9.226
	17	18.535	13.507	17.409	12.639	16.284	11.771	15.158	10.904	14.033	10.036	12.683	8.995
	18	19.315	13.291	18.103	12.421	16.892	11.550	15.680	10.679	14.469	9.809	13.015	8.764
	19	20.095	13.076	18.797	12.203	17.500	11.329	16.202	10.455	14.905	9.581	13.347	8.533
	20	20.878	12.858	19.520	11.957	18.161	11.056	16.802	10.155	15.444	9.253	13.813	8.172
28	18	19.315	16.157	18.103	15.286	16.892	14.416	15.680	13.545	14.469	12.674	13.015	11.630
	19	20.095	15.942	18.797	15.068	17.500	14.194	16.202	13.321	14.905	12.447	13.347	11.399
	20	20.878	15.724	19.520	14.823	18.161	13.921	16.802	13.020	15.444	12.119	13.813	11.037
	21	21.664	15.504	20.261	14.559	18.858	13.614	17.455	12.669	16.052	11.724	14.369	10.590
	22	22.449	15.284	21.002	14.295	19.555	13.306	18.107	12.317	16.660	11.328	14.924	10.142
	23	23.234	15.064	21.743	14.031	20.251	12.998	18.760	11.966	17.268	10.933	15.479	9.694
	24	24.019	14.844	22.484	13.767	20.948	12.691	19.412	11.614	17.876	10.538	16.034	9.246
30	20	20.878	17.157	19.520	16.255	18.161	15.354	16.802	14.453	15.444	13.552	13.813	12.470
	21	21.664	16.937	20.261	15.992	18.858	15.047	17.455	14.102	16.052	13.156	14.369	12.022
	22	22.449	16.717	21.002	15.728	19.555	14.739	18.107	13.750	16.660	12.761	14.924	11.574
	23	23.234	16.497	21.743	15.464	20.251	14.431	18.760	13.399	17.268	12.366	15.479	11.127
	24	24.019	16.277	22.484	15.200	20.948	14.124	19.412	13.047	17.876	11.971	16.034	10.679

Heating Mode

ID DB°C	Outdoor WB°C													
	-9		-6		-5		6		12		15		18	
	TC(kW)	SC(kW)	TC(kW)	SC(kW)	TC(kW)	SC(kW)	TC(kW)	SC(kW)	TC(kW)	SC(kW)	TC(kW)	SC(kW)	TC(kW)	SC(kW)
15	9.190	9.190	10.827	10.827	11.373	11.373	17.377	17.377	20.653	20.653	22.290	22.290	23.928	23.928
17	9.126	9.126	10.660	10.660	11.171	11.171	17.056	17.056	20.097	20.097	21.672	21.672	23.248	23.248
19	9.062	9.062	10.493	10.493	10.970	10.970	16.734	16.734	19.542	19.542	21.055	21.055	22.567	22.567
21	8.998	8.998	10.325	10.325	10.768	10.768	16.413	16.413	18.987	18.987	20.437	20.437	21.887	21.887
23	8.822	8.822	10.130	10.130	10.566	10.566	15.867	15.867	18.431	18.431	19.819	19.819	21.207	21.207
25	8.646	8.646	9.935	9.935	10.364	10.364	15.322	15.322	17.876	17.876	19.202	19.202	20.527	20.527
27	8.470	8.470	9.740	9.740	10.163	10.163	14.777	14.777	17.321	17.321	18.584	18.584	19.847	19.847
FROST REGION														

R410A Models (Cooling only)

Model : M5CC 010C / M5LC 010C

ID DB°C	ID WB°C	Outdoor DB°C											
		20		25		30		35		40		46	
		TC(kW)	SC(kW)	TC(kW)	SC(kW)	TC(kW)	SC(kW)	TC(kW)	SC(kW)	TC(kW)	SC(kW)	TC(kW)	SC(kW)
20	15	2.706	1.810	2.561	1.645	2.391	1.493	2.222	1.342	2.053	1.190	1.850	1.009
	16	2.812	1.712	2.665	1.563	2.506	1.421	2.346	1.279	2.187	1.137	1.995	0.967
24	16	2.812	2.192	2.665	2.043	2.506	1.901	2.346	1.759	2.187	1.617	1.995	1.447
	17	2.919	2.094	2.769	1.961	2.620	1.829	2.470	1.696	2.320	1.564	2.141	1.405
	18	3.037	1.989	2.892	1.869	2.748	1.748	2.604	1.628	2.460	1.507	2.287	1.363
	19	3.158	1.886	3.033	1.790	2.909	1.693	2.784	1.596	2.624	1.471	2.432	1.321
	20	3.269	1.773	3.118	1.648	2.967	1.522	2.816	1.396	2.665	1.270	2.483	1.120
28	18	3.037	2.469	2.892	2.349	2.748	2.228	2.604	2.108	2.460	1.987	2.287	1.843
	19	3.158	2.367	3.033	2.270	2.909	2.173	2.784	2.076	2.624	1.951	2.432	1.801
	20	3.269	2.254	3.118	2.128	2.967	2.002	2.816	1.876	2.665	1.751	2.483	1.600
	21	3.384	2.143	3.220	2.000	3.057	1.857	2.894	1.714	2.730	1.570	2.535	1.399
	22	3.498	2.032	3.322	1.872	3.147	1.711	2.972	1.551	2.796	1.390	2.586	1.198
	23	3.612	1.921	3.425	1.743	3.237	1.566	3.049	1.388	2.862	1.210	2.637	0.997
	24	3.727	1.810	3.527	1.615	3.327	1.420	3.127	1.225	2.928	1.030	2.688	0.796
30	20	3.269	2.494	3.118	2.368	2.967	2.242	2.816	2.116	2.665	1.991	2.483	1.840
	21	3.384	2.383	3.220	2.240	3.057	2.097	2.894	1.954	2.730	1.811	2.535	1.639
	22	3.498	2.272	3.322	2.112	3.147	1.951	2.972	1.791	2.796	1.630	2.586	1.438
	23	3.612	2.161	3.425	1.984	3.237	1.806	3.049	1.628	2.862	1.450	2.637	1.237
	24	3.727	2.051	3.527	1.855	3.327	1.660	3.127	1.465	2.928	1.270	2.688	1.036

Model : M5CC 015C / M5LC 015C

ID DB°C	ID WB°C	Outdoor DB°C											
		20		25		30		35		40		46	
		TC(kW)	SC(kW)	TC(kW)	SC(kW)	TC(kW)	SC(kW)	TC(kW)	SC(kW)	TC(kW)	SC(kW)	TC(kW)	SC(kW)
20	15	4.065	2.506	3.758	2.198	3.459	1.899	3.159	1.599	2.860	1.300	2.501	0.940
	16	4.162	2.306	3.862	2.029	3.567	1.756	3.272	1.483	2.977	1.211	2.623	0.883
24	16	4.162	3.198	3.862	2.922	3.567	2.649	3.272	2.376	2.977	2.104	2.623	1.776
	17	4.258	2.998	3.967	2.752	3.676	2.506	3.385	2.260	3.094	2.014	2.745	1.719
	18	4.350	2.794	4.065	2.576	3.780	2.359	3.495	2.141	3.209	1.924	2.867	1.662
	19	4.447	2.580	4.185	2.344	3.924	2.108	3.663	1.872	3.356	1.751	2.989	1.606
	20	4.533	2.377	4.248	2.176	3.963	1.976	3.678	1.775	3.394	1.574	3.052	1.333
28	18	4.350	3.687	4.065	3.469	3.780	3.252	3.495	3.034	3.209	2.816	2.867	2.555
	19	4.447	3.473	4.185	3.237	3.924	3.001	3.663	2.765	3.356	2.644	2.989	2.499
	20	4.533	3.270	4.248	3.069	3.963	2.869	3.678	2.668	3.394	2.467	3.052	2.226
	21	4.624	3.058	4.333	2.846	4.043	2.633	3.753	2.421	3.463	2.209	3.114	1.954
	22	4.714	2.846	4.418	2.622	4.123	2.398	3.827	2.174	3.532	1.951	3.177	1.682
	23	4.804	2.633	4.503	2.398	4.203	2.163	3.902	1.928	3.601	1.692	3.240	1.410
	24	4.895	2.421	4.588	2.174	4.282	1.928	3.976	1.681	3.670	1.434	3.303	1.138
30	20	4.533	3.717	4.248	3.516	3.963	3.315	3.678	3.114	3.394	2.914	3.052	2.673
	21	4.624	3.504	4.333	3.292	4.043	3.080	3.753	2.868	3.463	2.655	3.114	2.401
	22	4.714	3.292	4.418	3.068	4.123	2.845	3.827	2.621	3.532	2.397	3.177	2.129
	23	4.804	3.080	4.503	2.845	4.203	2.609	3.902	2.374	3.601	2.139	3.240	1.856
	24	4.895	2.868	4.588	2.621	4.282	2.374	3.976	2.127	3.670	1.881	3.303	1.584

R410A Models (Cooling only)

Model : M5CC 020C / M5LC 020C (1 & 3 Phase)

ID DB°C	ID WB°C	Outdoor DB°C											
		20		25		30		35		40		46	
		TC(kW)	SC(kW)	TC(kW)	SC(kW)	TC(kW)	SC(kW)	TC(kW)	SC(kW)	TC(kW)	SC(kW)	TC(kW)	SC(kW)
20	15	5.573	3.432	5.192	3.050	4.831	2.689	4.471	2.328	4.110	1.968	3.678	1.535
	16	5.747	3.183	5.375	2.841	5.014	2.510	4.652	2.179	4.291	1.848	3.857	1.451
24	16	5.747	4.408	5.375	4.067	5.014	3.736	4.652	3.405	4.291	3.074	3.857	2.677
	17	5.921	4.159	5.558	3.858	5.196	3.557	4.834	3.256	4.471	2.955	4.037	2.594
	18	6.085	3.901	5.725	3.633	5.366	3.366	5.007	3.098	4.647	2.831	4.216	2.510
	19	6.255	3.633	5.928	3.352	5.602	3.072	5.275	2.791	4.875	2.625	4.396	2.426
	20	6.409	3.371	6.040	3.113	5.670	2.854	5.301	2.595	4.932	2.337	4.488	2.026
28	18	6.085	5.127	5.725	4.859	5.366	4.592	5.007	4.324	4.647	4.057	4.216	3.736
	19	6.255	4.858	5.928	4.578	5.602	4.298	5.275	4.017	4.875	3.851	4.396	3.652
	20	6.409	4.597	6.040	4.339	5.670	4.080	5.301	3.821	4.932	3.562	4.488	3.252
	21	6.570	4.327	6.188	4.043	5.805	3.760	5.422	3.476	5.040	3.192	4.580	2.852
	22	6.731	4.056	6.335	3.748	5.939	3.439	5.544	3.131	5.148	2.822	4.673	2.452
	23	6.892	3.786	6.483	3.452	6.074	3.119	5.665	2.785	5.256	2.452	4.765	2.052
	24	7.053	3.515	6.630	3.157	6.208	2.798	5.786	2.440	5.364	2.082	4.857	1.651
30	20	6.409	5.210	6.040	4.952	5.670	4.693	5.301	4.434	4.932	4.175	4.488	3.865
	21	6.570	4.940	6.188	4.656	5.805	4.372	5.422	4.089	5.040	3.805	4.580	3.465
	22	6.731	4.669	6.335	4.361	5.939	4.052	5.544	3.744	5.148	3.435	4.673	3.065
	23	6.892	4.399	6.483	4.065	6.074	3.732	5.665	3.398	5.256	3.065	4.765	2.665
	24	7.053	4.128	6.630	3.770	6.208	3.411	5.786	3.053	5.364	2.695	4.857	2.264

Model : M5CC 025C / M5LC 025C (1 Phase)

ID DB°C	ID WB°C	Outdoor DB°C											
		20		25		30		35		40		46	
		TC(kW)	SC(kW)	TC(kW)	SC(kW)	TC(kW)	SC(kW)	TC(kW)	SC(kW)	TC(kW)	SC(kW)	TC(kW)	SC(kW)
20	15	6.376	4.301	5.942	3.867	5.532	3.457	5.123	3.047	4.713	2.638	4.221	2.146
	16	6.595	4.025	6.179	3.635	5.775	3.258	5.372	2.880	4.968	2.503	4.484	2.050
24	16	6.595	5.210	6.179	4.821	5.775	4.443	5.372	4.066	4.968	3.689	4.484	3.236
	17	6.813	4.934	6.416	4.589	6.018	4.244	5.621	3.899	5.224	3.554	4.748	3.140
	18	7.020	4.646	6.633	4.338	6.247	4.030	5.861	3.722	5.474	3.414	5.011	3.044
	19	7.230	4.351	6.871	4.046	6.512	3.741	6.153	3.436	5.753	3.214	5.274	2.948
	20	7.428	4.056	7.035	3.755	6.642	3.453	6.249	3.152	5.856	2.851	5.385	2.489
28	18	7.020	5.831	6.633	5.523	6.247	5.215	5.861	4.907	5.474	4.599	5.011	4.230
	19	7.230	5.537	6.871	5.232	6.512	4.927	6.153	4.622	5.753	4.400	5.274	4.134
	20	7.428	5.242	7.035	4.940	6.642	4.639	6.249	4.338	5.856	4.036	5.385	3.675
	21	7.629	4.940	7.219	4.609	6.808	4.277	6.398	3.945	5.988	3.614	5.495	3.216
	22	7.830	4.639	7.402	4.277	6.975	3.915	6.547	3.553	6.119	3.191	5.606	2.757
	23	8.031	4.337	7.586	3.945	7.141	3.553	6.696	3.161	6.251	2.769	5.717	2.298
	24	8.232	4.036	7.770	3.613	7.307	3.191	6.845	2.768	6.383	2.346	5.828	1.839
30	20	7.428	5.835	7.035	5.533	6.642	5.232	6.249	4.931	5.856	4.629	5.385	4.268
	21	7.629	5.533	7.219	5.202	6.808	4.870	6.398	4.538	5.988	4.207	5.495	3.809
	22	7.830	5.232	7.402	4.870	6.975	4.508	6.547	4.146	6.119	3.784	5.606	3.350
	23	8.031	4.930	7.586	4.538	7.141	4.146	6.696	3.754	6.251	3.362	5.717	2.891
	24	8.232	4.629	7.770	4.206	7.307	3.784	6.845	3.361	6.383	2.939	5.828	2.432

R410A Models (Cooling only)

Model : MCC 025C / M5LC 025C (3 Phase)

ID DB°C	ID WB°C	Outdoor DB°C											
		20		25		30		35		40		46	
		TC(kW)	SC(kW)	TC(kW)	SC(kW)	TC(kW)	SC(kW)	TC(kW)	SC(kW)	TC(kW)	SC(kW)	TC(kW)	SC(kW)
20	15	6.762	4.382	6.428	4.010	6.040	3.682	5.652	3.353	5.264	3.025	4.798	2.631
	16	6.991	4.143	6.642	3.814	6.266	3.506	5.890	3.199	5.515	2.891	5.064	2.522
24	16	6.991	5.381	6.642	5.052	6.266	4.744	5.890	4.437	5.515	4.129	5.064	3.760
	17	7.219	5.143	6.856	4.856	6.492	4.569	6.129	4.282	5.765	3.995	5.329	3.651
	18	7.473	4.884	7.111	4.626	6.750	4.368	6.389	4.110	6.028	3.852	5.594	3.542
	19	7.729	4.623	7.385	4.384	7.042	4.146	6.698	3.907	6.317	3.692	5.860	3.433
	20	7.974	4.350	7.591	4.073	7.208	3.797	6.825	3.520	6.442	3.244	5.983	2.912
28	18	7.473	6.122	7.111	5.864	6.750	5.606	6.389	5.348	6.028	5.090	5.594	4.781
	19	7.729	5.861	7.385	5.622	7.042	5.384	6.698	5.145	6.317	4.930	5.860	4.672
	20	7.974	5.588	7.591	5.312	7.208	5.035	6.825	4.758	6.442	4.482	5.983	4.150
	21	8.222	5.314	7.815	4.990	7.408	4.666	7.001	4.341	6.594	4.017	6.106	3.628
	22	8.470	5.040	8.039	4.668	7.608	4.296	7.177	3.924	6.746	3.553	6.229	3.106
	23	8.718	4.765	8.263	4.346	7.808	3.927	7.353	3.507	6.898	3.088	6.352	2.585
	24	8.966	4.491	8.487	4.024	8.008	3.557	7.529	3.090	7.050	2.623	6.475	2.063
	20	7.974	6.208	7.591	5.931	7.208	5.654	6.825	5.378	6.442	5.101	5.983	4.769
30	21	8.222	5.933	7.815	5.609	7.408	5.285	7.001	4.961	6.594	4.636	6.106	4.247
	22	8.470	5.659	8.039	5.287	7.608	4.915	7.177	4.544	6.746	4.172	6.229	3.726
	23	8.718	5.385	8.263	4.965	7.808	4.546	7.353	4.126	6.898	3.707	6.352	3.204
	24	8.966	5.110	8.487	4.643	8.008	4.176	7.529	3.709	7.050	3.243	6.475	2.682

Model : MCC 028C / M5LC 028C (1 Phase)

ID DB°C	ID WB°C	Outdoor DB°C											
		20		25		30		35		40		46	
		TC(kW)	SC(kW)	TC(kW)	SC(kW)	TC(kW)	SC(kW)	TC(kW)	SC(kW)	TC(kW)	SC(kW)	TC(kW)	SC(kW)
20	15	7.824	4.862	7.367	4.405	6.959	3.998	6.551	3.590	6.144	3.183	5.655	2.694
	16	8.106	4.542	7.656	4.142	7.230	3.767	6.804	3.391	6.379	3.016	5.868	2.565
24	16	8.106	6.233	7.656	5.833	7.230	5.457	6.804	5.082	6.379	4.707	5.868	4.256
	17	8.389	5.914	7.945	5.570	7.501	5.227	7.057	4.883	6.613	4.540	6.081	4.127
	18	8.649	5.572	8.196	5.269	7.743	4.967	7.290	4.664	6.837	4.362	6.294	3.999
	19	8.915	5.211	8.483	4.861	8.052	4.510	7.620	4.159	7.114	4.028	6.506	3.871
	20	9.166	4.869	8.681	4.559	8.196	4.249	7.710	3.938	7.225	3.628	6.643	3.256
28	18	8.649	7.262	8.196	6.960	7.743	6.657	7.290	6.355	6.837	6.053	6.294	5.690
	19	8.915	6.902	8.483	6.551	8.052	6.201	7.620	5.850	7.114	5.719	6.506	5.561
	20	9.166	6.560	8.681	6.250	8.196	5.939	7.710	5.629	7.225	5.319	6.643	4.947
	21	9.423	6.200	8.915	5.840	8.406	5.481	7.898	5.122	7.390	4.763	6.780	4.332
	22	9.680	5.839	9.149	5.431	8.617	5.023	8.086	4.615	7.554	4.207	6.916	3.718
	23	9.937	5.479	9.383	5.022	8.828	4.565	8.273	4.108	7.719	3.651	7.053	3.103
	24	10.195	5.119	9.617	4.613	9.039	4.107	8.461	3.601	7.883	3.095	7.190	2.488
30	20	9.166	7.405	8.681	7.095	8.196	6.785	7.710	6.474	7.225	6.164	6.643	5.792
	21	9.423	7.045	8.915	6.686	8.406	6.327	7.898	5.968	7.390	5.608	6.780	5.177
	22	9.680	6.685	9.149	6.277	8.617	5.869	8.086	5.461	7.554	5.053	6.916	4.563
	23	9.937	6.325	9.383	5.868	8.828	5.411	8.273	4.954	7.719	4.497	7.053	3.948
	24	10.195	5.964	9.617	5.459	9.039	4.953	8.461	4.447	7.883	3.941	7.190	3.334

R410A Models (Cooling only)

Model : M5CC 038C / M5LC 028C (3 Phase)

ID DB°C	ID WB°C	Outdoor DB°C											
		20		25		30		35		40		46	
		TC(kW)	SC(kW)	TC(kW)	SC(kW)	TC(kW)	SC(kW)	TC(kW)	SC(kW)	TC(kW)	SC(kW)	TC(kW)	SC(kW)
20	15	8.251	5.153	7.617	4.519	6.996	3.898	6.376	3.278	5.755	2.658	5.011	1.914
	16	8.522	4.762	7.927	4.187	7.339	3.619	6.751	3.050	6.163	2.482	5.458	1.800
24	16	8.522	6.531	7.927	5.956	7.339	5.387	6.751	4.819	6.163	4.251	5.458	3.568
	17	8.793	6.140	8.238	5.624	7.682	5.107	7.127	4.591	6.572	4.074	5.905	3.455
	18	9.057	5.744	8.537	5.282	8.017	4.819	7.497	4.357	6.977	3.895	6.352	3.341
	19	9.325	5.340	8.854	4.896	8.384	4.452	7.913	4.009	7.407	3.653	6.800	3.227
	20	9.575	4.934	9.069	4.501	8.563	4.068	8.056	3.635	7.550	3.202	6.942	2.682
28	18	9.057	7.512	8.537	7.050	8.017	6.588	7.497	6.126	6.977	5.664	6.352	5.109
	19	9.325	7.108	8.854	6.665	8.384	6.221	7.913	5.778	7.407	5.422	6.800	4.996
	20	9.575	6.703	9.069	6.270	8.563	5.837	8.056	5.404	7.550	4.971	6.942	4.451
	21	9.829	6.290	9.301	5.832	8.773	5.373	8.246	4.915	7.718	4.456	7.085	3.906
	22	10.082	5.877	9.533	5.394	8.984	4.910	8.435	4.426	7.886	3.942	7.228	3.362
	23	10.335	5.464	9.765	4.955	9.195	4.446	8.625	3.937	8.055	3.428	7.371	2.817
	24	10.588	5.052	9.997	4.517	9.406	3.983	8.814	3.448	8.223	2.914	7.513	2.273
	20	9.575	7.587	9.069	7.154	8.563	6.721	8.056	6.288	7.550	5.855	6.942	5.335
30	21	9.829	7.174	9.301	6.716	8.773	6.258	8.246	5.799	7.718	5.341	7.085	4.791
	22	10.082	6.762	9.533	6.278	8.984	5.794	8.435	5.310	7.886	4.827	7.228	4.246
	23	10.335	6.349	9.765	5.840	9.195	5.331	8.625	4.822	8.055	4.312	7.371	3.702
	24	10.588	5.936	9.997	5.402	9.406	4.867	8.814	4.333	8.223	3.798	7.513	3.157

Model : M5CC 038C / M5LC 040C

ID DB°C	ID WB°C	Outdoor DB°C											
		20		25		30		35		40		46	
		TC(kW)	SC(kW)	TC(kW)	SC(kW)	TC(kW)	SC(kW)	TC(kW)	SC(kW)	TC(kW)	SC(kW)	TC(kW)	SC(kW)
20	15	11.603	7.400	10.747	6.543	9.919	5.715	9.091	4.887	8.263	4.059	7.270	3.065
	16	12.029	6.894	11.211	6.115	10.407	5.349	9.603	4.584	8.799	3.819	7.834	2.900
24	16	12.029	9.298	11.211	8.518	10.407	7.753	9.603	6.988	8.799	6.222	7.834	5.304
	17	12.456	8.792	11.675	8.090	10.895	7.387	10.114	6.684	9.334	5.982	8.397	5.139
	18	12.869	8.274	12.118	7.639	11.366	7.004	10.615	6.370	9.863	5.735	8.961	4.973
	19	13.302	7.759	12.678	7.215	12.054	6.671	11.430	6.126	10.564	5.527	9.525	4.808
	20	13.683	7.213	12.922	6.599	12.161	5.984	11.399	5.369	10.638	4.755	9.725	4.017
28	18	12.869	10.677	12.118	10.043	11.366	9.408	10.615	8.773	9.863	8.139	8.961	7.377
	19	13.302	10.163	12.678	9.619	12.054	9.074	11.430	8.530	10.564	7.931	9.525	7.212
	20	13.683	9.617	12.922	9.002	12.161	8.388	11.399	7.773	10.638	7.159	9.725	6.421
	21	14.082	9.075	13.283	8.412	12.484	7.750	11.684	7.088	10.885	6.425	9.925	5.630
	22	14.482	8.533	13.644	7.823	12.807	7.113	11.969	6.402	11.131	5.692	10.125	4.840
	23	14.882	7.991	14.006	7.233	13.130	6.475	12.253	5.717	11.377	4.959	10.325	4.049
	24	15.282	7.449	14.367	6.643	13.453	5.837	12.538	5.031	11.623	4.226	10.525	3.258
	20	13.683	10.819	12.922	10.204	12.161	9.589	11.399	8.975	10.638	8.360	9.725	7.623
30	21	14.082	10.277	13.283	9.614	12.484	8.952	11.684	8.290	10.885	7.627	9.925	6.832
	22	14.482	9.735	13.644	9.025	12.807	8.314	11.969	7.604	11.131	6.894	10.125	6.042
	23	14.882	9.193	14.006	8.435	13.130	7.677	12.253	6.919	11.377	6.161	10.325	5.251
	24	15.282	8.651	14.367	7.845	13.453	7.039	12.538	6.233	11.623	5.427	10.525	4.460

R410A Models (Cooling only)

Model : M5CC 050C / M5LC 050C

ID DB°C	ID WB°C	Outdoor DB°C											
		20		25		30		35		40		46	
		TC(kW)	SC(kW)	TC(kW)	SC(kW)	TC(kW)	SC(kW)	TC(kW)	SC(kW)	TC(kW)	SC(kW)	TC(kW)	SC(kW)
20	15	15.123	10.307	13.959	9.142	12.820	8.002	11.682	6.862	10.543	5.722	9.176	4.354
	16	15.548	9.587	14.434	8.530	13.333	7.486	12.232	6.442	11.131	5.398	9.810	4.145
24	16	15.548	12.348	14.434	11.291	13.333	10.247	12.232	9.203	11.131	8.159	9.810	6.906
	17	15.972	11.628	14.909	10.679	13.846	9.731	12.783	8.783	11.720	7.835	10.444	6.697
	18	16.385	10.896	15.364	10.048	14.344	9.201	13.323	8.353	12.302	7.505	11.078	6.488
	19	16.810	10.149	15.891	9.328	14.973	8.507	14.054	7.686	12.989	7.047	11.712	6.280
	20	17.196	9.403	16.189	8.610	15.181	7.818	14.174	7.025	13.166	6.232	11.958	5.281
28	18	16.385	13.656	15.364	12.809	14.344	11.961	13.323	11.114	12.302	10.266	11.078	9.249
	19	16.810	12.910	15.891	12.089	14.973	11.268	14.054	10.446	12.989	9.807	11.712	9.040
	20	17.196	12.164	16.189	11.371	15.181	10.578	14.174	9.786	13.166	8.993	11.958	8.042
	21	17.595	11.403	16.558	10.564	15.521	9.726	14.484	8.887	13.448	8.049	12.203	7.043
	22	17.993	10.642	16.927	9.757	15.861	8.873	14.795	7.989	13.729	7.105	12.449	6.044
	23	18.392	9.881	17.296	8.951	16.201	8.021	15.105	7.091	14.010	6.161	12.695	5.046
30	24	18.790	9.120	17.665	8.144	16.541	7.168	15.416	6.193	14.291	5.217	12.941	4.047
	20	17.196	13.544	16.189	12.751	15.181	11.959	14.174	11.166	13.166	10.373	11.958	9.422
	21	17.595	12.783	16.558	11.945	15.521	11.106	14.484	10.268	13.448	9.429	12.203	8.423
	22	17.993	12.022	16.927	11.138	15.861	10.254	14.795	9.370	13.729	8.485	12.449	7.425
	23	18.392	11.261	17.296	10.331	16.201	9.401	15.105	8.471	14.010	7.542	12.695	6.426
24	18.790	10.500	17.665	9.524	16.541	8.549	15.416	7.573	14.291	6.598	12.941	5.427	

Model : M5CC 060C / M5LC 061C

ID DB°C	ID WB°C	Outdoor DB°C											
		20		25		30		35		40		46	
		TC(kW)	SC(kW)	TC(kW)	SC(kW)	TC(kW)	SC(kW)	TC(kW)	SC(kW)	TC(kW)	SC(kW)	TC(kW)	SC(kW)
20	15	15.647	9.904	14.731	8.989	13.914	8.171	13.096	7.353	12.278	6.536	11.297	5.554
	16	16.336	9.329	15.500	8.514	14.713	7.748	13.926	6.982	13.139	6.217	12.195	5.298
24	16	16.336	12.610	15.500	11.796	14.713	11.030	13.926	10.264	13.139	9.498	12.195	8.579
	17	17.025	12.035	16.268	11.321	15.512	10.607	14.756	9.893	14.000	9.179	13.093	8.323
	18	17.668	11.414	16.961	10.770	16.254	10.126	15.547	9.482	14.839	8.838	13.991	8.066
	19	18.289	10.793	17.517	10.219	16.745	9.645	15.973	9.071	15.480	8.498	14.889	7.809
	20	18.933	10.136	18.216	9.453	17.498	8.769	16.780	8.085	16.063	7.401	15.201	6.581
28	18	17.668	14.695	16.961	14.052	16.254	13.408	15.547	12.764	14.839	12.120	13.991	11.347
	19	18.289	14.075	17.517	13.501	16.745	12.927	15.973	12.353	15.480	11.779	14.889	11.091
	20	18.933	13.418	18.216	12.734	17.498	12.050	16.780	11.367	16.063	10.683	15.201	9.862
	21	19.555	12.761	18.778	11.967	18.001	11.174	17.224	10.380	16.447	9.586	15.514	8.634
	22	20.177	12.104	19.340	11.201	18.504	10.297	17.667	9.393	16.831	8.490	15.827	7.406
	23	20.799	11.447	19.903	10.434	19.007	9.420	18.111	8.407	17.215	7.393	16.139	6.177
30	24	21.420	10.790	20.465	9.667	19.509	8.544	18.554	7.420	17.599	6.297	16.452	4.949
	20	18.933	15.059	18.216	14.375	17.498	13.691	16.780	13.007	16.063	12.323	15.201	11.503
	21	19.555	14.402	18.778	13.608	18.001	12.814	17.224	12.021	16.447	11.227	15.514	10.275
	22	20.177	13.745	19.340	12.841	18.504	11.938	17.667	11.034	16.831	10.131	15.827	9.046
	23	20.799	13.088	19.903	12.075	19.007	11.061	18.111	10.048	17.215	9.034	16.139	7.818
24	21.420	12.431	20.465	11.308	19.509	10.185	18.554	9.061	17.599	7.938	16.452	6.590	

R410A Models (Heatpump)

Model : M5CC 010CR / M5LC 010CR
Cooling Mode

ID DB°C	ID WB°C	Outdoor DB°C											
		20		25		30		35		40		46	
		TC(kW)	SC(kW)	TC(kW)	SC(kW)	TC(kW)	SC(kW)	TC(kW)	SC(kW)	TC(kW)	SC(kW)	TC(kW)	SC(kW)
20	15	2.706	1.810	2.561	1.645	2.391	1.493	2.222	1.342	2.053	1.190	1.850	1.009
	16	2.812	1.712	2.665	1.563	2.506	1.421	2.346	1.279	2.187	1.137	1.995	0.967
24	16	2.812	2.192	2.665	2.043	2.506	1.901	2.346	1.759	2.187	1.617	1.995	1.447
	17	2.919	2.094	2.769	1.961	2.620	1.829	2.470	1.696	2.320	1.564	2.141	1.405
	18	3.037	1.989	2.892	1.869	2.748	1.748	2.604	1.628	2.460	1.507	2.287	1.363
	19	3.158	1.886	3.033	1.790	2.909	1.693	2.784	1.596	2.624	1.471	2.432	1.321
	20	3.269	1.773	3.118	1.648	2.967	1.522	2.816	1.396	2.665	1.270	2.483	1.120
28	18	3.037	2.469	2.892	2.349	2.748	2.228	2.604	2.108	2.460	1.987	2.287	1.843
	19	3.158	2.367	3.033	2.270	2.909	2.173	2.784	2.076	2.624	1.951	2.432	1.801
	20	3.269	2.254	3.118	2.128	2.967	2.002	2.816	1.876	2.665	1.751	2.483	1.600
	21	3.384	2.143	3.220	2.000	3.057	1.857	2.894	1.714	2.730	1.570	2.535	1.399
	22	3.498	2.032	3.322	1.872	3.147	1.711	2.972	1.551	2.796	1.390	2.586	1.198
	23	3.612	1.921	3.425	1.743	3.237	1.566	3.049	1.388	2.862	1.210	2.637	0.997
	24	3.727	1.810	3.527	1.615	3.327	1.420	3.127	1.225	2.928	1.030	2.688	0.796
30	20	3.269	2.494	3.118	2.368	2.967	2.242	2.816	2.116	2.665	1.991	2.483	1.840
	21	3.384	2.383	3.220	2.240	3.057	2.097	2.894	1.954	2.730	1.811	2.535	1.639
	22	3.498	2.272	3.322	2.112	3.147	1.951	2.972	1.791	2.796	1.630	2.586	1.438
	23	3.612	2.161	3.425	1.984	3.237	1.806	3.049	1.628	2.862	1.450	2.637	1.237
	24	3.727	2.051	3.527	1.855	3.327	1.660	3.127	1.465	2.928	1.270	2.688	1.036

Heating Mode

ID DB°C	Outdoor WB°C													
	-9		-6		-5		6		12		15		18	
	TC(kW)	SC(kW)	TC(kW)	SC(kW)	TC(kW)	SC(kW)	TC(kW)	SC(kW)	TC(kW)	SC(kW)	TC(kW)	SC(kW)	TC(kW)	SC(kW)
15	1.683	1.683	1.905	1.905	1.979	1.979	2.793	2.793	3.236	3.236	3.458	3.458	3.680	3.680
17	1.639	1.639	1.882	1.882	1.939	1.939	2.789	2.789	3.213	3.213	3.438	3.438	3.663	3.663
19	1.595	1.595	1.858	1.858	1.899	1.899	2.786	2.786	3.190	3.190	3.418	3.418	3.645	3.645
21	1.551	1.551	1.820	1.820	1.859	1.859	2.760	2.760	3.166	3.166	3.397	3.397	3.628	3.628
23	1.507	1.507	1.766	1.766	1.818	1.818	2.713	2.713	3.143	3.143	3.377	3.377	3.610	3.610
25	1.463	1.463	1.712	1.712	1.778	1.778	2.665	2.665	3.120	3.120	3.356	3.356	3.593	3.593
27	1.418	1.418	1.658	1.658	1.738	1.738	2.617	2.617	3.096	3.096	3.336	3.336	3.576	3.576
FROST REGION														

R410A Models (Heatpump)

Model : M5CC 015CR / M5LC 015CR
Cooling Mode

ID DB°C	ID WB°C	Outdoor DB°C											
		20		25		30		35		40		46	
		TC(kW)	SC(kW)	TC(kW)	SC(kW)	TC(kW)	SC(kW)	TC(kW)	SC(kW)	TC(kW)	SC(kW)	TC(kW)	SC(kW)
20	15	4.065	2.506	3.758	2.198	3.459	1.899	3.159	1.599	2.860	1.300	2.501	0.940
	16	4.162	2.306	3.862	2.029	3.567	1.756	3.272	1.483	2.977	1.211	2.623	0.883
24	16	4.162	3.198	3.862	2.922	3.567	2.649	3.272	2.376	2.977	2.104	2.623	1.776
	17	4.258	2.998	3.967	2.752	3.676	2.506	3.385	2.260	3.094	2.014	2.745	1.719
	18	4.350	2.794	4.065	2.576	3.780	2.359	3.495	2.141	3.209	1.924	2.867	1.662
	19	4.447	2.580	4.185	2.344	3.924	2.108	3.663	1.872	3.356	1.751	2.989	1.606
28	20	4.533	2.377	4.248	2.176	3.963	1.976	3.678	1.775	3.394	1.574	3.052	1.333
	18	4.350	3.687	4.065	3.469	3.780	3.252	3.495	3.034	3.209	2.816	2.867	2.555
	19	4.447	3.473	4.185	3.237	3.924	3.001	3.663	2.765	3.356	2.644	2.989	2.499
	20	4.533	3.270	4.248	3.069	3.963	2.869	3.678	2.668	3.394	2.467	3.052	2.226
	21	4.624	3.058	4.333	2.846	4.043	2.633	3.753	2.421	3.463	2.209	3.114	1.954
	22	4.714	2.846	4.418	2.622	4.123	2.398	3.827	2.174	3.532	1.951	3.177	1.682
30	23	4.804	2.633	4.503	2.398	4.203	2.163	3.902	1.928	3.601	1.692	3.240	1.410
	24	4.895	2.421	4.588	2.174	4.282	1.928	3.976	1.681	3.670	1.434	3.303	1.138
	20	4.533	3.717	4.248	3.516	3.963	3.315	3.678	3.114	3.394	2.914	3.052	2.673
	21	4.624	3.504	4.333	3.292	4.043	3.080	3.753	2.868	3.463	2.655	3.114	2.401
30	22	4.714	3.292	4.418	3.068	4.123	2.845	3.827	2.621	3.532	2.397	3.177	2.129
	23	4.804	3.080	4.503	2.845	4.203	2.609	3.902	2.374	3.601	2.139	3.240	1.856
	24	4.895	2.868	4.588	2.621	4.282	2.374	3.976	2.127	3.670	1.881	3.303	1.584

Heating Mode

ID DB°C	Outdoor WB°C													
	-9		-6		-5		6		12		15		18	
	TC(kW)	SC(kW)	TC(kW)	SC(kW)	TC(kW)	SC(kW)	TC(kW)	SC(kW)	TC(kW)	SC(kW)	TC(kW)	SC(kW)	TC(kW)	SC(kW)
15	2.126	2.126	2.406	2.406	2.500	2.500	3.528	3.528	4.088	4.088	4.368	4.368	4.649	4.649
17	2.070	2.070	2.358	2.358	2.434	2.434	3.523	3.523	3.978	3.978	4.251	4.251	4.524	4.524
19	2.015	2.015	2.310	2.310	2.368	2.368	3.519	3.519	3.869	3.869	4.134	4.134	4.398	4.398
21	1.959	1.959	2.249	2.249	2.302	2.302	3.438	3.438	3.759	3.759	4.016	4.016	4.273	4.273
23	1.903	1.903	2.174	2.174	2.236	2.236	3.279	3.279	3.649	3.649	3.899	3.899	4.148	4.148
25	1.847	1.847	2.100	2.100	2.170	2.170	3.120	3.120	3.540	3.540	3.781	3.781	4.023	4.023
27	1.792	1.792	2.026	2.026	2.104	2.104	2.962	2.962	3.430	3.430	3.664	3.664	3.898	3.898
FROST REGION														

R410A Models (Heatpump)

Model : M5CC 020CR / M5LC 020CR (1 & 3 Phase) Cooling Mode

ID DB°C	ID WB°C	Outdoor DB°C											
		20		25		30		35		40		46	
		TC(kW)	SC(kW)	TC(kW)	SC(kW)	TC(kW)	SC(kW)	TC(kW)	SC(kW)	TC(kW)	SC(kW)	TC(kW)	SC(kW)
20	15	5.573	3.432	5.192	3.05	4.831	2.689	4.471	2.328	4.11	1.968	3.678	1.535
	16	5.747	3.183	5.375	2.841	5.014	2.51	4.652	2.179	4.291	1.848	3.857	1.451
24	16	5.747	4.408	5.375	4.067	5.014	3.736	4.652	3.405	4.291	3.074	3.857	2.677
	17	5.921	4.159	5.558	3.858	5.196	3.557	4.834	3.256	4.471	2.955	4.037	2.594
	18	6.085	3.901	5.725	3.633	5.366	3.366	5.007	3.098	4.647	2.831	4.216	2.51
	19	6.255	3.633	5.928	3.352	5.602	3.072	5.275	2.791	4.875	2.625	4.396	2.426
	20	6.409	3.371	6.04	3.113	5.67	2.854	5.301	2.595	4.932	2.337	4.488	2.026
28	18	6.085	5.127	5.725	4.859	5.366	4.592	5.007	4.324	4.647	4.057	4.216	3.736
	19	6.255	4.858	5.928	4.578	5.602	4.298	5.275	4.017	4.875	3.851	4.396	3.652
	20	6.409	4.597	6.04	4.339	5.67	4.08	5.301	3.821	4.932	3.562	4.488	3.252
	21	6.57	4.327	6.188	4.043	5.805	3.76	5.422	3.476	5.04	3.192	4.58	2.852
	22	6.731	4.056	6.335	3.748	5.939	3.439	5.544	3.131	5.148	2.822	4.673	2.452
	23	6.892	3.786	6.483	3.452	6.074	3.119	5.665	2.785	5.256	2.452	4.765	2.052
	24	7.053	3.515	6.63	3.157	6.208	2.798	5.786	2.44	5.364	2.082	4.857	1.651
30	20	6.409	5.21	6.04	4.952	5.67	4.693	5.301	4.434	4.932	4.175	4.488	3.865
	21	6.57	4.94	6.188	4.656	5.805	4.372	5.422	4.089	5.04	3.805	4.58	3.465
	22	6.731	4.669	6.335	4.361	5.939	4.052	5.544	3.744	5.148	3.435	4.673	3.065
	23	6.892	4.399	6.483	4.065	6.074	3.732	5.665	3.398	5.256	3.065	4.765	2.665
	24	7.053	4.128	6.63	3.77	6.208	3.411	5.786	3.053	5.364	2.695	4.857	2.264

Heating Mode

ID DB°C	Outdoor WB°C													
	-9		-6		-5		6		12		15		18	
	TC(kW)	SC(kW)	TC(kW)	SC(kW)	TC(kW)	SC(kW)	TC(kW)	SC(kW)	TC(kW)	SC(kW)	TC(kW)	SC(kW)	TC(kW)	SC(kW)
15	3.278	3.278	3.710	3.710	3.854	3.854	5.438	5.438	6.302	6.302	6.735	6.735	7.167	7.167
17	3.192	3.192	3.609	3.609	3.777	3.777	5.432	5.432	6.266	6.266	6.705	6.705	7.145	7.145
19	3.106	3.106	3.509	3.509	3.701	3.701	5.425	5.425	6.230	6.230	6.676	6.676	7.122	7.122
21	3.020	3.020	3.427	3.427	3.624	3.624	5.381	5.381	6.194	6.194	6.647	6.647	7.100	7.100
23	2.934	2.934	3.363	3.363	3.548	3.548	5.299	5.299	6.157	6.157	6.618	6.618	7.078	7.078
25	2.848	2.848	3.300	3.300	3.472	3.472	5.217	5.217	6.121	6.121	6.589	6.589	7.056	7.056
27	2.762	2.762	3.237	3.237	3.395	3.395	5.135	5.135	6.085	6.085	6.559	6.559	7.034	7.034
FROST REGION														

R410A Models (Heatpump)

Model : M5CC 025CR / M5LC 025CR (1 Phase)
Cooling Mode

ID DB°C	ID WB°C	Outdoor DB°C											
		20		25		30		35		40		46	
		TC(kW)	SC(kW)	TC(kW)	SC(kW)	TC(kW)	SC(kW)	TC(kW)	SC(kW)	TC(kW)	SC(kW)	TC(kW)	SC(kW)
20	15	6.376	4.301	5.942	3.867	5.532	3.457	5.123	3.047	4.713	2.638	4.221	2.146
	16	6.595	4.025	6.179	3.635	5.775	3.258	5.372	2.880	4.968	2.503	4.484	2.050
24	16	6.595	5.210	6.179	4.821	5.775	4.443	5.372	4.066	4.968	3.689	4.484	3.236
	17	6.813	4.934	6.416	4.589	6.018	4.244	5.621	3.899	5.224	3.554	4.748	3.140
	18	7.020	4.646	6.633	4.338	6.247	4.030	5.861	3.722	5.474	3.414	5.011	3.044
	19	7.230	4.351	6.871	4.046	6.512	3.741	6.153	3.436	5.753	3.214	5.274	2.948
	20	7.428	4.056	7.035	3.755	6.642	3.453	6.249	3.152	5.856	2.851	5.385	2.489
28	18	7.020	5.831	6.633	5.523	6.247	5.215	5.861	4.907	5.474	4.599	5.011	4.230
	19	7.230	5.537	6.871	5.232	6.512	4.927	6.153	4.622	5.753	4.400	5.274	4.134
	20	7.428	5.242	7.035	4.940	6.642	4.639	6.249	4.338	5.856	4.036	5.385	3.675
	21	7.629	4.940	7.219	4.609	6.808	4.277	6.398	3.945	5.988	3.614	5.495	3.216
	22	7.830	4.639	7.402	4.277	6.975	3.915	6.547	3.553	6.119	3.191	5.606	2.757
	23	8.031	4.337	7.586	3.945	7.141	3.553	6.696	3.161	6.251	2.769	5.717	2.298
	24	8.232	4.036	7.770	3.613	7.307	3.191	6.845	2.768	6.383	2.346	5.828	1.839
30	20	7.428	5.835	7.035	5.533	6.642	5.232	6.249	4.931	5.856	4.629	5.385	4.268
	21	7.629	5.533	7.219	5.202	6.808	4.870	6.398	4.538	5.988	4.207	5.495	3.809
	22	7.830	5.232	7.402	4.870	6.975	4.508	6.547	4.146	6.119	3.784	5.606	3.350
	23	8.031	4.930	7.586	4.538	7.141	4.146	6.696	3.754	6.251	3.362	5.717	2.891
	24	8.232	4.629	7.770	4.206	7.307	3.784	6.845	3.361	6.383	2.939	5.828	2.432

Heating Mode

ID DB°C	Outdoor WB°C													
	-9		-6		-5		6		12		15		18	
	TC(kW)	SC(kW)	TC(kW)	SC(kW)	TC(kW)	SC(kW)	TC(kW)	SC(kW)	TC(kW)	SC(kW)	TC(kW)	SC(kW)	TC(kW)	SC(kW)
15	3.898	3.898	4.412	4.412	4.583	4.583	6.467	6.467	7.495	7.495	8.009	8.009	8.523	8.523
17	3.796	3.796	4.406	4.406	4.503	4.503	6.459	6.459	7.507	7.507	8.037	8.037	8.568	8.568
19	3.694	3.694	4.399	4.399	4.422	4.422	6.452	6.452	7.519	7.519	8.066	8.066	8.613	8.613
21	3.591	3.591	4.325	4.325	4.342	4.342	6.433	6.433	7.532	7.532	8.095	8.095	8.658	8.658
23	3.489	3.489	4.182	4.182	4.261	4.261	6.404	6.404	7.544	7.544	8.123	8.123	8.703	8.703
25	3.387	3.387	4.039	4.039	4.181	4.181	6.374	6.374	7.556	7.556	8.152	8.152	8.748	8.748
27	3.285	3.285	3.897	3.897	4.101	4.101	6.345	6.345	7.569	7.569	8.181	8.181	8.792	8.792
FROST REGION														

R410A Models (Heatpump)

Model : M5CC 025CR / M5LC 025CR (3 Phase) Cooling Mode

ID DB°C	ID WB°C	Outdoor DB°C											
		20		25		30		35		40		46	
		TC(kW)	SC(kW)	TC(kW)	SC(kW)	TC(kW)	SC(kW)	TC(kW)	SC(kW)	TC(kW)	SC(kW)	TC(kW)	SC(kW)
20	15	6.762	4.382	6.428	4.010	6.040	3.682	5.652	3.353	5.264	3.025	4.798	2.631
	16	6.991	4.143	6.642	3.814	6.266	3.506	5.890	3.199	5.515	2.891	5.064	2.522
24	16	6.991	5.381	6.642	5.052	6.266	4.744	5.890	4.437	5.515	4.129	5.064	3.760
	17	7.219	5.143	6.856	4.856	6.492	4.569	6.129	4.282	5.765	3.995	5.329	3.651
	18	7.473	4.884	7.111	4.626	6.750	4.368	6.389	4.110	6.028	3.852	5.594	3.542
	19	7.729	4.623	7.385	4.384	7.042	4.146	6.698	3.907	6.317	3.692	5.860	3.433
	20	7.974	4.350	7.591	4.073	7.208	3.797	6.825	3.520	6.442	3.244	5.983	2.912
28	18	7.473	6.122	7.111	5.864	6.750	5.606	6.389	5.348	6.028	5.090	5.594	4.781
	19	7.729	5.861	7.385	5.622	7.042	5.384	6.698	5.145	6.317	4.930	5.860	4.672
	20	7.974	5.588	7.591	5.312	7.208	5.035	6.825	4.758	6.442	4.482	5.983	4.150
	21	8.222	5.314	7.815	4.990	7.408	4.666	7.001	4.341	6.594	4.017	6.106	3.628
	22	8.470	5.040	8.039	4.668	7.608	4.296	7.177	3.924	6.746	3.553	6.229	3.106
	23	8.718	4.765	8.263	4.346	7.808	3.927	7.353	3.507	6.898	3.088	6.352	2.585
30	24	8.966	4.491	8.487	4.024	8.008	3.557	7.529	3.090	7.050	2.623	6.475	2.063
	20	7.974	6.208	7.591	5.931	7.208	5.654	6.825	5.378	6.442	5.101	5.983	4.769
	21	8.222	5.933	7.815	5.609	7.408	5.285	7.001	4.961	6.594	4.636	6.106	4.247
	22	8.470	5.659	8.039	5.287	7.608	4.915	7.177	4.544	6.746	4.172	6.229	3.726
	23	8.718	5.385	8.263	4.965	7.808	4.546	7.353	4.126	6.898	3.707	6.352	3.204
	24	8.966	5.110	8.487	4.643	8.008	4.176	7.529	3.709	7.050	3.243	6.475	2.682

Heating Mode

ID DB°C	Outdoor WB°C													
	-9		-6		-5		6		12		15		18	
	TC(kW)	SC(kW)	TC(kW)	SC(kW)	TC(kW)	SC(kW)	TC(kW)	SC(kW)	TC(kW)	SC(kW)	TC(kW)	SC(kW)	TC(kW)	SC(kW)
15	4.110	4.110	4.652	4.652	4.833	4.833	6.820	6.820	7.904	7.904	8.446	8.446	8.987	8.987
17	4.003	4.003	4.538	4.538	4.724	4.724	6.812	6.812	7.790	7.790	8.331	8.331	8.872	8.872
19	3.895	3.895	4.424	4.424	4.615	4.615	6.804	6.804	7.676	7.676	8.216	8.216	8.756	8.756
21	3.787	3.787	4.315	4.315	4.506	4.506	6.706	6.706	7.562	7.562	8.102	8.102	8.641	8.641
23	3.679	3.679	4.210	4.210	4.397	4.397	6.520	6.520	7.448	7.448	7.987	7.987	8.525	8.525
25	3.572	3.572	4.105	4.105	4.288	4.288	6.334	6.334	7.335	7.335	7.872	7.872	8.410	8.410
27	3.464	3.464	4.001	4.001	4.180	4.180	6.147	6.147	7.221	7.221	7.758	7.758	8.294	8.294
FROST REGION														

R410A Models (Heatpump)

Model : M5CC 028CR / M5LC 028CR (1 & 3 Phase) Cooling Mode

ID DB°C	ID WB°C	Outdoor DB°C											
		20		25		30		35		40		46	
		TC(kW)	SC(kW)	TC(kW)	SC(kW)	TC(kW)	SC(kW)	TC(kW)	SC(kW)	TC(kW)	SC(kW)	TC(kW)	SC(kW)
20	15	7.824	4.862	7.367	4.405	6.959	3.998	6.551	3.590	6.144	3.183	5.655	2.694
	16	8.106	4.542	7.656	4.142	7.230	3.767	6.804	3.391	6.379	3.016	5.868	2.565
24	16	8.106	6.233	7.656	5.833	7.230	5.457	6.804	5.082	6.379	4.707	5.868	4.256
	17	8.389	5.914	7.945	5.570	7.501	5.227	7.057	4.883	6.613	4.540	6.081	4.127
	18	8.649	5.572	8.196	5.269	7.743	4.967	7.290	4.664	6.837	4.362	6.294	3.999
	19	8.915	5.211	8.483	4.861	8.052	4.510	7.620	4.159	7.114	4.028	6.506	3.871
28	20	9.166	4.869	8.681	4.559	8.196	4.249	7.710	3.938	7.225	3.628	6.643	3.256
	18	8.649	7.262	8.196	6.960	7.743	6.657	7.290	6.355	6.837	6.053	6.294	5.690
	19	8.915	6.902	8.483	6.551	8.052	6.201	7.620	5.850	7.114	5.719	6.506	5.561
	20	9.166	6.560	8.681	6.250	8.196	5.939	7.710	5.629	7.225	5.319	6.643	4.947
	21	9.423	6.200	8.915	5.840	8.406	5.481	7.898	5.122	7.390	4.763	6.780	4.332
	22	9.680	5.839	9.149	5.431	8.617	5.023	8.086	4.615	7.554	4.207	6.916	3.718
	23	9.937	5.479	9.383	5.022	8.828	4.565	8.273	4.108	7.719	3.651	7.053	3.103
30	24	10.195	5.119	9.617	4.613	9.039	4.107	8.461	3.601	7.883	3.095	7.190	2.488
	20	9.166	7.405	8.681	7.095	8.196	6.785	7.710	6.474	7.225	6.164	6.643	5.792
	21	9.423	7.045	8.915	6.686	8.406	6.327	7.898	5.968	7.390	5.608	6.780	5.177
	22	9.680	6.685	9.149	6.277	8.617	5.869	8.086	5.461	7.554	5.053	6.916	4.563
	23	9.937	6.325	9.383	5.868	8.828	5.411	8.273	4.954	7.719	4.497	7.053	3.948
	24	10.195	5.964	9.617	5.459	9.039	4.953	8.461	4.447	7.883	3.941	7.190	3.334

Heating Mode

ID DB°C	Outdoor WB°C													
	-9		-6		-5		6		12		15		18	
	TC(kW)	SC(kW)	TC(kW)	SC(kW)	TC(kW)	SC(kW)	TC(kW)	SC(kW)	TC(kW)	SC(kW)	TC(kW)	SC(kW)	TC(kW)	SC(kW)
15	4.607	4.607	5.214	5.214	5.416	5.416	7.643	7.643	8.858	8.858	9.465	9.465	10.072	10.072
17	4.486	4.486	5.074	5.074	5.288	5.288	7.634	7.634	8.695	8.695	9.297	9.297	9.898	9.898
19	4.365	4.365	4.935	4.935	5.159	5.159	7.625	7.625	8.533	8.533	9.128	9.128	9.724	9.724
21	4.244	4.244	4.806	4.806	5.030	5.030	7.494	7.494	8.371	8.371	8.960	8.960	9.550	9.550
23	4.124	4.124	4.689	4.689	4.902	4.902	7.243	7.243	8.208	8.208	8.792	8.792	9.375	9.375
25	4.003	4.003	4.571	4.571	4.773	4.773	6.992	6.992	8.046	8.046	8.624	8.624	9.201	9.201
27	3.882	3.882	4.454	4.454	4.644	4.644	6.740	6.740	7.884	7.884	8.455	8.455	9.027	9.027
FROST REGION														

R410A Models (Heatpump)

Model : M5CC 028CR / M5LC 028CR (3 Phase)
Cooling Mode

ID DB°C	ID WB°C	Outdoor DB°C											
		20		25		30		35		40		46	
		TC(kW)	SC(kW)	TC(kW)	SC(kW)	TC(kW)	SC(kW)	TC(kW)	SC(kW)	TC(kW)	SC(kW)	TC(kW)	SC(kW)
20	15	8.251	5.153	7.617	4.519	6.996	3.898	6.376	3.278	5.755	2.658	5.011	1.914
	16	8.522	4.762	7.927	4.187	7.339	3.619	6.751	3.050	6.163	2.482	5.458	1.800
24	16	8.522	6.531	7.927	5.956	7.339	5.387	6.751	4.819	6.163	4.251	5.458	3.568
	17	8.793	6.140	8.238	5.624	7.682	5.107	7.127	4.591	6.572	4.074	5.905	3.455
	18	9.057	5.744	8.537	5.282	8.017	4.819	7.497	4.357	6.977	3.895	6.352	3.341
	19	9.325	5.340	8.854	4.896	8.384	4.452	7.913	4.009	7.407	3.653	6.800	3.227
28	20	9.575	4.934	9.069	4.501	8.563	4.068	8.056	3.635	7.550	3.202	6.942	2.682
	18	9.057	7.512	8.537	7.050	8.017	6.588	7.497	6.126	6.977	5.664	6.352	5.109
	19	9.325	7.108	8.854	6.665	8.384	6.221	7.913	5.778	7.407	5.422	6.800	4.996
	20	9.575	6.703	9.069	6.270	8.563	5.837	8.056	5.404	7.550	4.971	6.942	4.451
	21	9.829	6.290	9.301	5.832	8.773	5.373	8.246	4.915	7.718	4.456	7.085	3.906
	22	10.082	5.877	9.533	5.394	8.984	4.910	8.435	4.426	7.886	3.942	7.228	3.362
	23	10.335	5.464	9.765	4.955	9.195	4.446	8.625	3.937	8.055	3.428	7.371	2.817
30	24	10.588	5.052	9.997	4.517	9.406	3.983	8.814	3.448	8.223	2.914	7.513	2.273
	20	9.575	7.587	9.069	7.154	8.563	6.721	8.056	6.288	7.550	5.855	6.942	5.335
	21	9.829	7.174	9.301	6.716	8.773	6.258	8.246	5.799	7.718	5.341	7.085	4.791
	22	10.082	6.762	9.533	6.278	8.984	5.794	8.435	5.310	7.886	4.827	7.228	4.246
	23	10.335	6.349	9.765	5.840	9.195	5.331	8.625	4.822	8.055	4.312	7.371	3.702
	24	10.588	5.936	9.997	5.402	9.406	4.867	8.814	4.333	8.223	3.798	7.513	3.157

Heating Mode

ID DB°C	Outdoor WB°C													
	-9		-6		-5		6		12		15		18	
	TC(kW)	SC(kW)	TC(kW)	SC(kW)	TC(kW)	SC(kW)	TC(kW)	SC(kW)	TC(kW)	SC(kW)	TC(kW)	SC(kW)	TC(kW)	SC(kW)
15	4.961	4.961	5.615	5.615	5.833	5.833	8.231	8.231	9.539	9.539	10.193	10.193	10.847	10.847
17	4.831	4.831	5.467	5.467	5.700	5.700	8.221	8.221	9.396	9.396	10.048	10.048	10.700	10.700
19	4.701	4.701	5.320	5.320	5.568	5.568	8.211	8.211	9.252	9.252	9.903	9.903	10.553	10.553
21	4.571	4.571	5.186	5.186	5.435	5.435	8.090	8.090	9.109	9.109	9.757	9.757	10.406	10.406
23	4.441	4.441	5.065	5.065	5.303	5.303	7.858	7.858	8.966	8.966	9.612	9.612	10.259	10.259
25	4.311	4.311	4.944	4.944	5.170	5.170	7.626	7.626	8.823	8.823	9.467	9.467	10.112	10.112
27	4.181	4.181	4.823	4.823	5.038	5.038	7.394	7.394	8.679	8.679	9.322	9.322	9.965	9.965
FROST REGION														

R410A Models (Heatpump)

Model : M5CC 028CR / M5LC 035CR
Cooling Mode

ID DB°C	ID WB°C	Outdoor DB°C											
		20		25		30		35		40		46	
		TC(kW)	SC(kW)	TC(kW)	SC(kW)	TC(kW)	SC(kW)	TC(kW)	SC(kW)	TC(kW)	SC(kW)	TC(kW)	SC(kW)
20	15	8.230	5.119	7.650	4.538	7.097	3.985	6.544	3.431	5.991	2.878	5.328	2.214
	16	8.485	4.755	7.936	4.232	7.399	3.723	6.863	3.213	6.326	2.704	5.683	2.093
24	16	8.485	6.537	7.936	6.014	7.399	5.505	6.863	4.996	6.326	4.486	5.683	3.875
	17	8.741	6.174	8.221	5.708	7.701	5.243	7.182	4.778	6.662	4.312	6.038	3.754
	18	8.985	5.797	8.486	5.381	7.988	4.965	7.489	4.549	6.991	4.132	6.393	3.633
	19	9.227	5.414	8.743	5.012	8.259	4.610	7.774	4.208	7.308	3.891	6.748	3.511
	20	9.464	5.028	8.969	4.625	8.473	4.222	7.978	3.819	7.483	3.415	6.889	2.932
28	18	8.985	7.580	8.486	7.164	7.988	6.747	7.489	6.331	6.991	5.915	6.393	5.415
	19	9.227	7.197	8.743	6.795	8.259	6.393	7.774	5.990	7.308	5.674	6.748	5.294
	20	9.464	6.811	8.969	6.407	8.473	6.004	7.978	5.601	7.483	5.198	6.889	4.714
	21	9.699	6.417	9.186	5.978	8.673	5.539	8.160	5.100	7.647	4.661	7.031	4.134
	22	9.934	6.024	9.403	5.549	8.872	5.074	8.341	4.599	7.810	4.124	7.173	3.554
	23	10.170	5.631	9.621	5.120	9.072	4.609	8.523	4.098	7.973	3.588	7.314	2.974
	24	10.405	5.238	9.838	4.691	9.271	4.144	8.704	3.598	8.137	3.051	7.456	2.395
30	20	9.464	7.702	8.969	7.299	8.473	6.895	7.978	6.492	7.483	6.089	6.889	5.605
	21	9.699	7.309	9.186	6.870	8.673	6.430	8.160	5.991	7.647	5.552	7.031	5.025
	22	9.934	6.915	9.403	6.440	8.872	5.965	8.341	5.490	7.810	5.016	7.173	4.446
	23	10.170	6.522	9.621	6.011	9.072	5.501	8.523	4.990	7.973	4.479	7.314	3.866
	24	10.405	6.129	9.838	5.582	9.271	5.036	8.704	4.489	8.137	3.942	7.456	3.286

Heating Mode

ID DB°C	Outdoor WB°C													
	-9		-6		-5		6		12		15		18	
	TC(kW)	SC(kW)	TC(kW)	SC(kW)	TC(kW)	SC(kW)	TC(kW)	SC(kW)	TC(kW)	SC(kW)	TC(kW)	SC(kW)	TC(kW)	SC(kW)
15	4.695	4.695	5.314	5.314	5.520	5.520	7.790	7.790	9.028	9.028	9.647	9.647	10.266	10.266
17	4.572	4.572	5.064	5.064	5.408	5.408	7.781	7.781	8.961	8.961	9.589	9.589	10.216	10.216
19	4.449	4.449	4.814	4.814	5.296	5.296	7.771	7.771	8.895	8.895	9.530	9.530	10.165	10.165
21	4.326	4.326	4.680	4.680	5.184	5.184	7.699	7.699	8.829	8.829	9.472	9.472	10.115	10.115
23	4.203	4.203	4.661	4.661	5.071	5.071	7.564	7.564	8.762	8.762	9.414	9.414	10.065	10.065
25	4.080	4.080	4.643	4.643	4.959	4.959	7.429	7.429	8.696	8.696	9.356	9.356	10.015	10.015
27	3.957	3.957	4.624	4.624	4.847	4.847	7.295	7.295	8.630	8.630	9.297	9.297	9.965	9.965
FROST REGION														

R410A Models (Heatpump)

Model : M5CC 038CR / M5LC 040CR
Cooling Mode

ID DB°C	ID WB°C	Outdoor DB°C											
		20		25		30		35		40		46	
		TC(kW)	SC(kW)	TC(kW)	SC(kW)	TC(kW)	SC(kW)	TC(kW)	SC(kW)	TC(kW)	SC(kW)	TC(kW)	SC(kW)
20	15	11.603	7.400	10.747	6.543	9.919	5.715	9.091	4.887	8.263	4.059	7.270	3.065
	16	12.029	6.894	11.211	6.115	10.407	5.349	9.603	4.584	8.799	3.819	7.834	2.900
24	16	12.029	9.298	11.211	8.518	10.407	7.753	9.603	6.988	8.799	6.222	7.834	5.304
	17	12.456	8.792	11.675	8.090	10.895	7.387	10.114	6.684	9.334	5.982	8.397	5.139
	18	12.869	8.274	12.118	7.639	11.366	7.004	10.615	6.370	9.863	5.735	8.961	4.973
	19	13.302	7.759	12.678	7.215	12.054	6.671	11.430	6.126	10.564	5.527	9.525	4.808
28	20	13.683	7.213	12.922	6.599	12.161	5.984	11.399	5.369	10.638	4.755	9.725	4.017
	18	12.869	10.677	12.118	10.043	11.366	9.408	10.615	8.773	9.863	8.139	8.961	7.377
	19	13.302	10.163	12.678	9.619	12.054	9.074	11.430	8.530	10.564	7.931	9.525	7.212
	20	13.683	9.617	12.922	9.002	12.161	8.388	11.399	7.773	10.638	7.159	9.725	6.421
	21	14.082	9.075	13.283	8.412	12.484	7.750	11.684	7.088	10.885	6.425	9.925	5.630
	22	14.482	8.533	13.644	7.823	12.807	7.113	11.969	6.402	11.131	5.692	10.125	4.840
	23	14.882	7.991	14.006	7.233	13.130	6.475	12.253	5.717	11.377	4.959	10.325	4.049
30	24	15.282	7.449	14.367	6.643	13.453	5.837	12.538	5.031	11.623	4.226	10.525	3.258
	20	13.683	10.819	12.922	10.204	12.161	9.589	11.399	8.975	10.638	8.360	9.725	7.623
	21	14.082	10.277	13.283	9.614	12.484	8.952	11.684	8.290	10.885	7.627	9.925	6.832
	22	14.482	9.735	13.644	9.025	12.807	8.314	11.969	7.604	11.131	6.894	10.125	6.042
	23	14.882	9.193	14.006	8.435	13.130	7.677	12.253	6.919	11.377	6.161	10.325	5.251
	24	15.282	8.651	14.367	7.845	13.453	7.039	12.538	6.233	11.623	5.427	10.525	4.460

Heating Mode

ID DB°C	Outdoor WB°C													
	-9		-6		-5		6		12		15		18	
	TC(kW)	SC(kW)	TC(kW)	SC(kW)	TC(kW)	SC(kW)	TC(kW)	SC(kW)	TC(kW)	SC(kW)	TC(kW)	SC(kW)	TC(kW)	SC(kW)
15	7.441	7.441	8.422	8.422	8.749	8.749	12.346	12.346	14.308	14.308	15.289	15.289	16.270	16.270
17	7.246	7.246	8.102	8.102	8.543	8.543	12.332	12.332	14.055	14.055	15.028	15.028	16.001	16.001
19	7.051	7.051	7.781	7.781	8.337	8.337	12.317	12.317	13.803	13.803	14.767	14.767	15.732	15.732
21	6.856	6.856	7.560	7.560	8.131	8.131	12.112	12.112	13.550	13.550	14.506	14.506	15.462	15.462
23	6.661	6.661	7.441	7.441	7.925	7.925	11.718	11.718	13.297	13.297	14.245	14.245	15.193	15.193
25	6.466	6.466	7.322	7.322	7.719	7.719	11.323	11.323	13.044	13.044	13.984	13.984	14.924	14.924
27	6.271	6.271	7.202	7.202	7.513	7.513	10.928	10.928	12.791	12.791	13.723	13.723	14.654	14.654
FROST REGION														

R410A Models (Heatpump)

Model : M5CC 050CR / M5LC 050CR Cooling Mode

ID DB°C	ID WB°C	Outdoor DB°C											
		20		25		30		35		40		46	
		TC(kW)	SC(kW)	TC(kW)	SC(kW)	TC(kW)	SC(kW)	TC(kW)	SC(kW)	TC(kW)	SC(kW)	TC(kW)	SC(kW)
20	15	15.123	10.307	13.959	9.142	12.820	8.002	11.682	6.862	10.543	5.722	9.176	4.354
	16	15.548	9.587	14.434	8.530	13.333	7.486	12.232	6.442	11.131	5.398	9.810	4.145
24	16	15.548	12.348	14.434	11.291	13.333	10.247	12.232	9.203	11.131	8.159	9.810	6.906
	17	15.972	11.628	14.909	10.679	13.846	9.731	12.783	8.783	11.720	7.835	10.444	6.697
	18	16.385	10.896	15.364	10.048	14.344	9.201	13.323	8.353	12.302	7.505	11.078	6.488
	19	16.810	10.149	15.891	9.328	14.973	8.507	14.054	7.686	12.989	7.047	11.712	6.280
	20	17.196	9.403	16.189	8.610	15.181	7.818	14.174	7.025	13.166	6.232	11.958	5.281
28	18	16.385	13.656	15.364	12.809	14.344	11.961	13.323	11.114	12.302	10.266	11.078	9.249
	19	16.810	12.910	15.891	12.089	14.973	11.268	14.054	10.446	12.989	9.807	11.712	9.040
	20	17.196	12.164	16.189	11.371	15.181	10.578	14.174	9.786	13.166	8.993	11.958	8.042
	21	17.595	11.403	16.558	10.564	15.521	9.726	14.484	8.887	13.448	8.049	12.203	7.043
	22	17.993	10.642	16.927	9.757	15.861	8.873	14.795	7.989	13.729	7.105	12.449	6.044
	23	18.392	9.881	17.296	8.951	16.201	8.021	15.105	7.091	14.010	6.161	12.695	5.046
	24	18.790	9.120	17.665	8.144	16.541	7.168	15.416	6.193	14.291	5.217	12.941	4.047
	25	19.188	8.360	18.044	7.338	16.881	6.311	15.721	5.311	14.571	4.367	13.181	3.048
30	20	17.196	13.544	16.189	12.751	15.181	11.959	14.174	11.166	13.166	10.373	11.958	9.422
	21	17.595	12.783	16.558	11.945	15.521	11.106	14.484	10.268	13.448	9.429	12.203	8.423
	22	17.993	12.022	16.927	11.138	15.861	10.254	14.795	9.370	13.729	8.485	12.449	7.425
	23	18.392	11.261	17.296	10.331	16.201	9.401	15.105	8.471	14.010	7.542	12.695	6.426
	24	18.790	10.500	17.665	9.524	16.541	8.549	15.416	7.573	14.291	6.598	12.941	5.427

Heating Mode

ID DB°C	Outdoor WB°C													
	-9		-6		-5		6		12		15		18	
	TC(kW)	SC(kW)	TC(kW)	SC(kW)	TC(kW)	SC(kW)	TC(kW)	SC(kW)	TC(kW)	SC(kW)	TC(kW)	SC(kW)	TC(kW)	SC(kW)
15	8.682	8.682	9.826	9.826	10.208	10.208	14.404	14.404	16.693	16.693	17.837	17.837	18.982	18.982
17	8.454	8.454	9.647	9.647	9.958	9.958	14.387	14.387	16.347	16.347	17.475	17.475	18.603	18.603
19	8.226	8.226	9.468	9.468	9.707	9.707	14.370	14.370	16.002	16.002	17.112	17.112	18.223	18.223
21	7.999	7.999	9.233	9.233	9.457	9.457	14.100	14.100	15.656	15.656	16.750	16.750	17.844	17.844
23	7.771	7.771	8.942	8.942	9.207	9.207	13.577	13.577	15.310	15.310	16.387	16.387	17.464	17.464
25	7.544	7.544	8.651	8.651	8.957	8.957	13.055	13.055	14.965	14.965	16.025	16.025	17.085	17.085
27	7.316	7.316	8.359	8.359	8.707	8.707	12.533	12.533	14.619	14.619	15.662	15.662	16.706	16.706

FROST REGION

R410A Models (Heatpump)

Model : M5CC 060CR / M5LC 061CR Cooling Mode

ID DB°C	ID WB°C	Outdoor DB°C											
		20		25		30		35		40		46	
		TC(kW)	SC(kW)	TC(kW)	SC(kW)	TC(kW)	SC(kW)	TC(kW)	SC(kW)	TC(kW)	SC(kW)	TC(kW)	SC(kW)
20	15	15.647	9.904	14.731	8.989	13.914	8.171	13.096	7.353	12.278	6.536	11.297	5.554
	16	16.336	9.329	15.500	8.514	14.713	7.748	13.926	6.982	13.139	6.217	12.195	5.298
24	16	16.336	12.610	15.500	11.796	14.713	11.030	13.926	10.264	13.139	9.498	12.195	8.579
	17	17.025	12.035	16.268	11.321	15.512	10.607	14.756	9.893	14.000	9.179	13.093	8.323
	18	17.668	11.414	16.961	10.770	16.254	10.126	15.547	9.482	14.839	8.838	13.991	8.066
	19	18.289	10.793	17.517	10.219	16.745	9.645	15.973	9.071	15.480	8.498	14.889	7.809
	20	18.933	10.136	18.216	9.453	17.498	8.769	16.780	8.085	16.063	7.401	15.201	6.581
	18	17.668	14.695	16.961	14.052	16.254	13.408	15.547	12.764	14.839	12.120	13.991	11.347
28	19	18.289	14.075	17.517	13.501	16.745	12.927	15.973	12.353	15.480	11.779	14.889	11.091
	20	18.933	13.418	18.216	12.734	17.498	12.050	16.780	11.367	16.063	10.683	15.201	9.862
	21	19.555	12.761	18.778	11.967	18.001	11.174	17.224	10.380	16.447	9.586	15.514	8.634
	22	20.177	12.104	19.340	11.201	18.504	10.297	17.667	9.393	16.831	8.490	15.827	7.406
	23	20.799	11.447	19.903	10.434	19.007	9.420	18.111	8.407	17.215	7.393	16.139	6.177
	24	21.420	10.790	20.465	9.667	19.509	8.544	18.554	7.420	17.599	6.297	16.452	4.949
30	20	18.933	15.059	18.216	14.375	17.498	13.691	16.780	13.007	16.063	12.323	15.201	11.503
	21	19.555	14.402	18.778	13.608	18.001	12.814	17.224	12.021	16.447	11.227	15.514	10.275
	22	20.177	13.745	19.340	12.841	18.504	11.938	17.667	11.034	16.831	10.131	15.827	9.046
	23	20.799	13.088	19.903	12.075	19.007	11.061	18.111	10.048	17.215	9.034	16.139	7.818
	24	21.420	12.431	20.465	11.308	19.509	10.185	18.554	9.061	17.599	7.938	16.452	6.590

Heating Mode

ID DB°C	Outdoor WB°C													
	-9		-6		-5		6		12		15		18	
	TC(kW)	SC(kW)	TC(kW)	SC(kW)	TC(kW)	SC(kW)	TC(kW)	SC(kW)	TC(kW)	SC(kW)	TC(kW)	SC(kW)	TC(kW)	SC(kW)
15	10.099	10.099	11.430	11.430	11.874	11.874	16.756	16.756	19.418	19.418	20.750	20.750	22.081	22.081
17	9.834	9.834	11.313	11.313	11.596	11.596	16.736	16.736	19.081	19.081	20.402	20.402	21.723	21.723
19	9.570	9.570	11.196	11.196	11.317	11.317	16.716	16.716	18.743	18.743	20.053	20.053	21.364	21.364
21	9.305	9.305	10.943	10.943	11.038	11.038	16.441	16.441	18.405	18.405	19.705	19.705	21.005	21.005
23	9.040	9.040	10.555	10.555	10.760	10.760	15.912	15.912	18.068	18.068	19.357	19.357	20.647	20.647
25	8.775	8.775	10.167	10.167	10.481	10.481	15.383	15.383	17.730	17.730	19.009	19.009	20.288	20.288
27	8.511	8.511	9.779	9.779	10.202	10.202	14.855	14.855	17.392	17.392	18.661	18.661	19.930	19.930
FROST REGION														

Dimensional Data

Indoor Unit

Model : MCC / M5CC 010C/CR

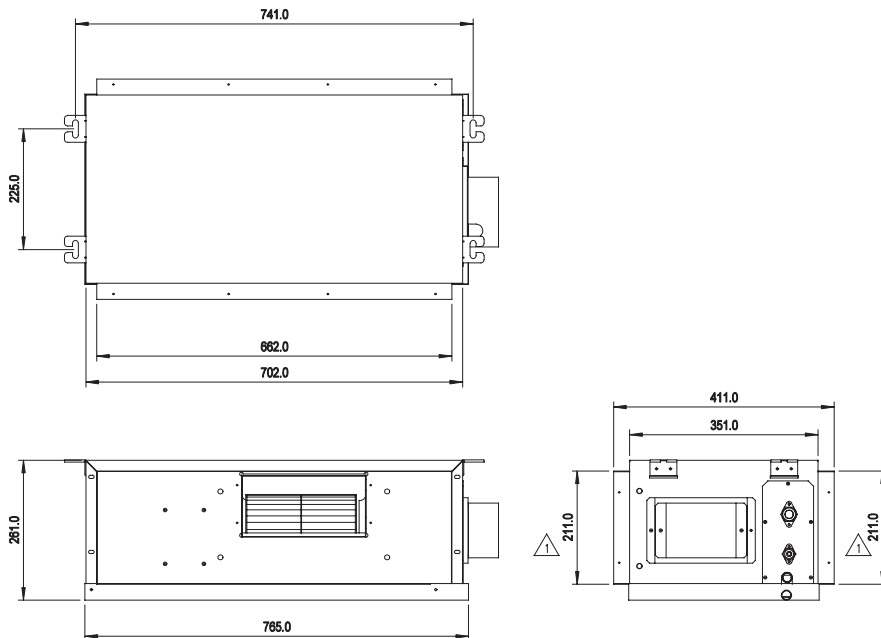

All Dimensions are in mm

Model : MCC / M5CC 015 ~ 025C/CR

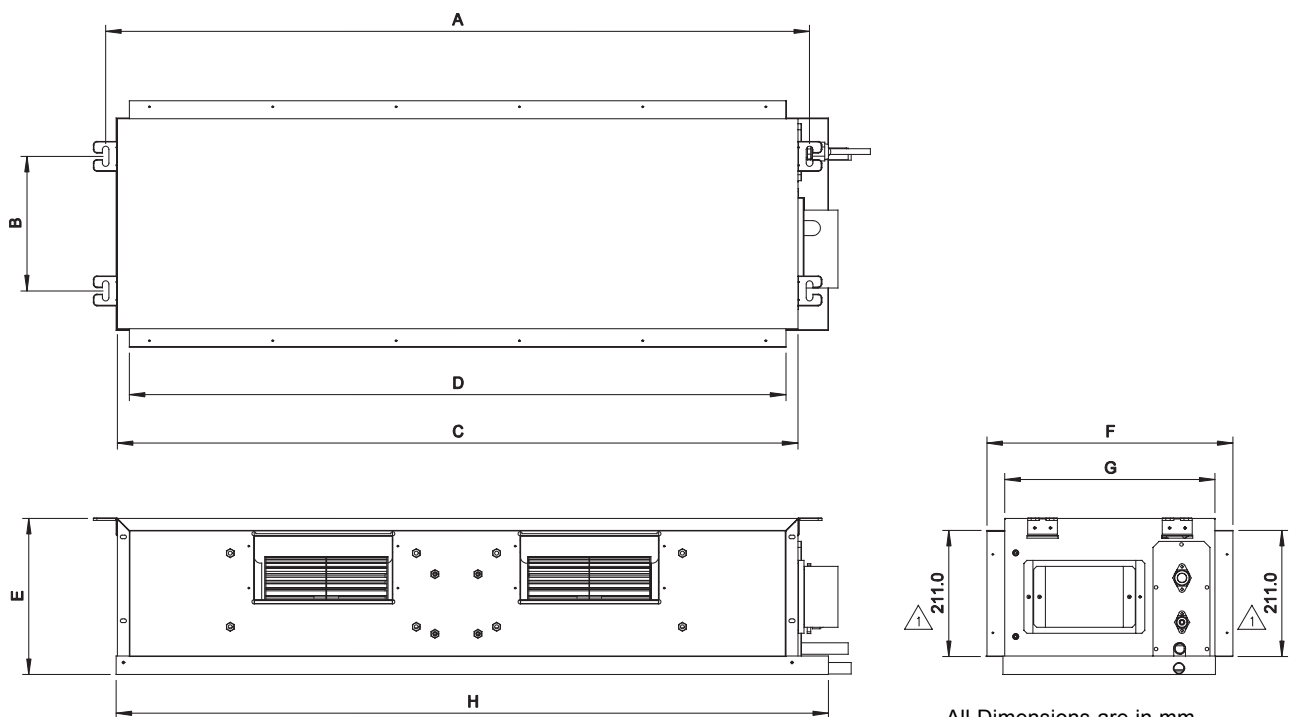

All Dimensions are in mm

MODEL	A	B	C	D	E	F	G	H
015C/CR	881.0	225.0	842.0	802.0	261.0	411.0	351.0	905.0
020C/CR	1041.0	225.0	1002.0	962.0	261.0	411.0	351.0	1065.0
025C/CR	1176.0	225.0	1137.0	1097.0	261.0	411.0	351.0	1200.0

Model : MCC / M5CC 028C/CR

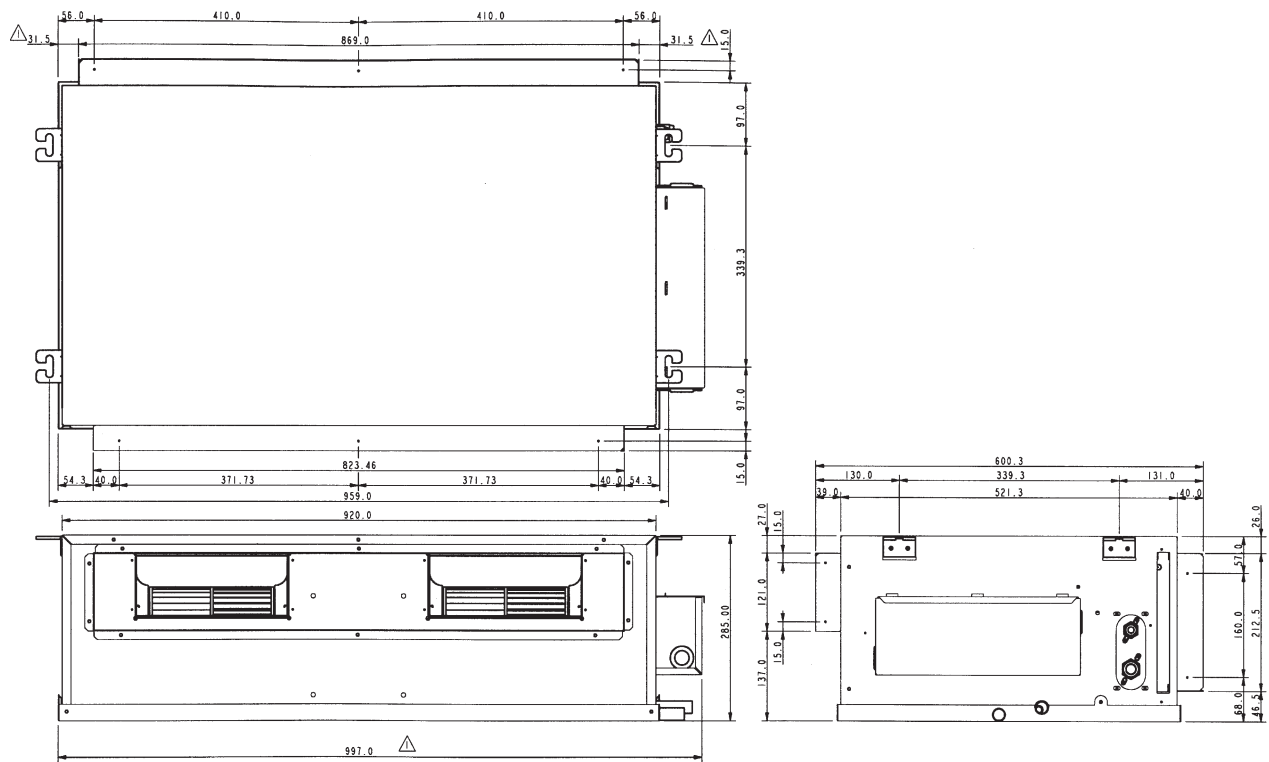

All dimension are in mm

Model : MCC / M5CC 038C/CR

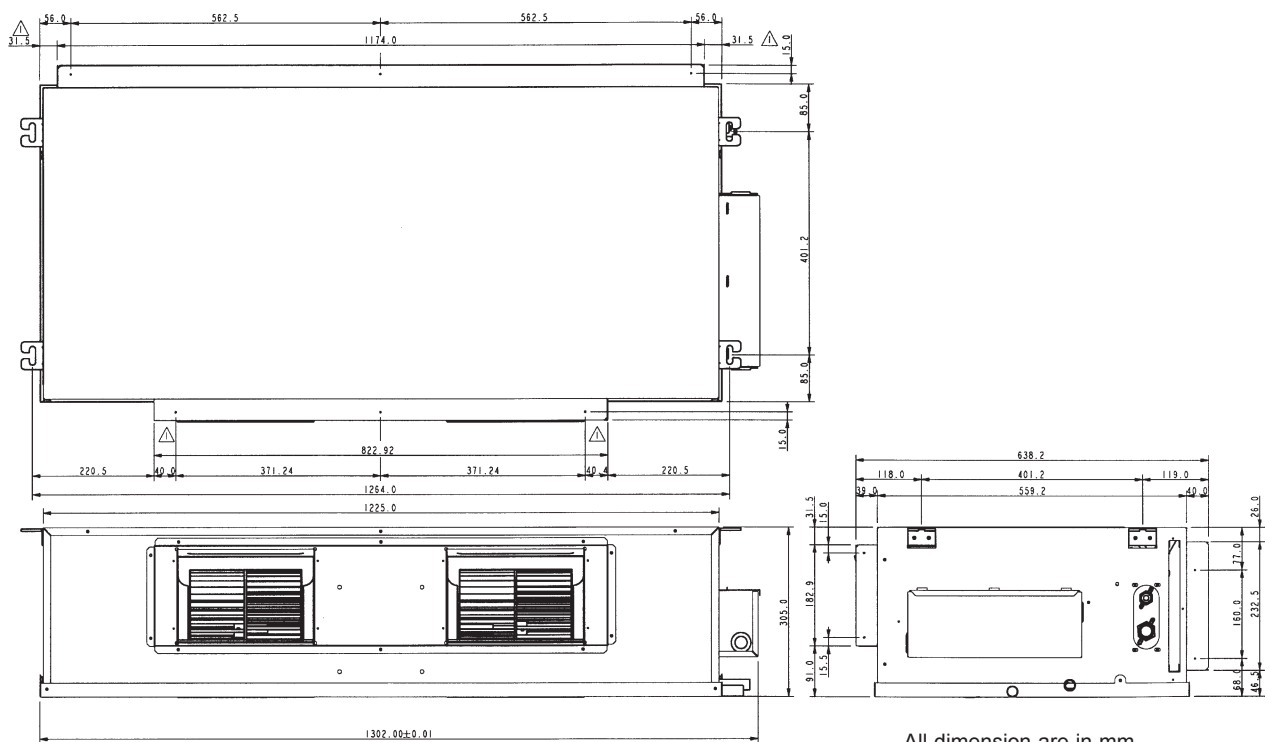

All dimension are in mm

Model : MCC 030 ~ 060 C/CR, M5CC 050 / 060C/CR

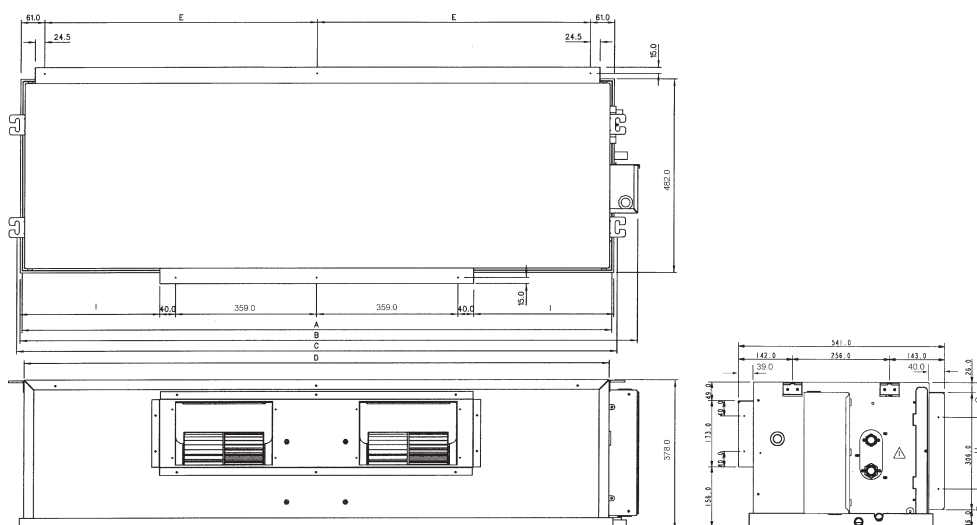

All dimension are in mm

Model	A	B	C	D	E	F	G	H	I
030C/CR	929.0	999.0	956.0	917.0	408.5	105.0	85.5	187.5	70.5
040C/CR	1045.0	1115.0	1072.0	1033.0	466.5	105.0	85.5	187.5	128.5
050C/CR	1299.0	1369.0	1326.0	1287.0	593.5	105.0	90.5	182.5	255.5
060C/CR	1499.0	1569.0	1526.0	1487.0	693.5	100.0	90.5	187.5	355.5

Outdoor Unit

Model : MLC / M5LC 010 / 015C/CR

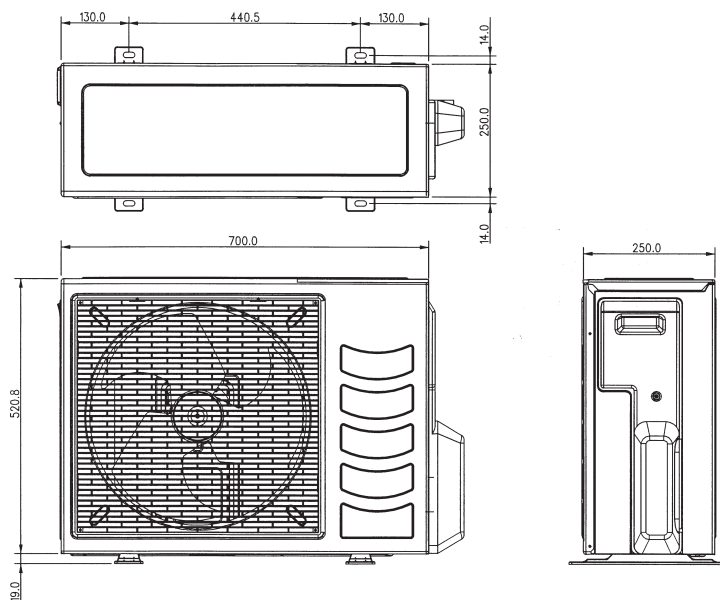

All dimension are in mm

**Model : MLC 018C/CR
MLC / M5LC 020 / 025 / 028C/CR**

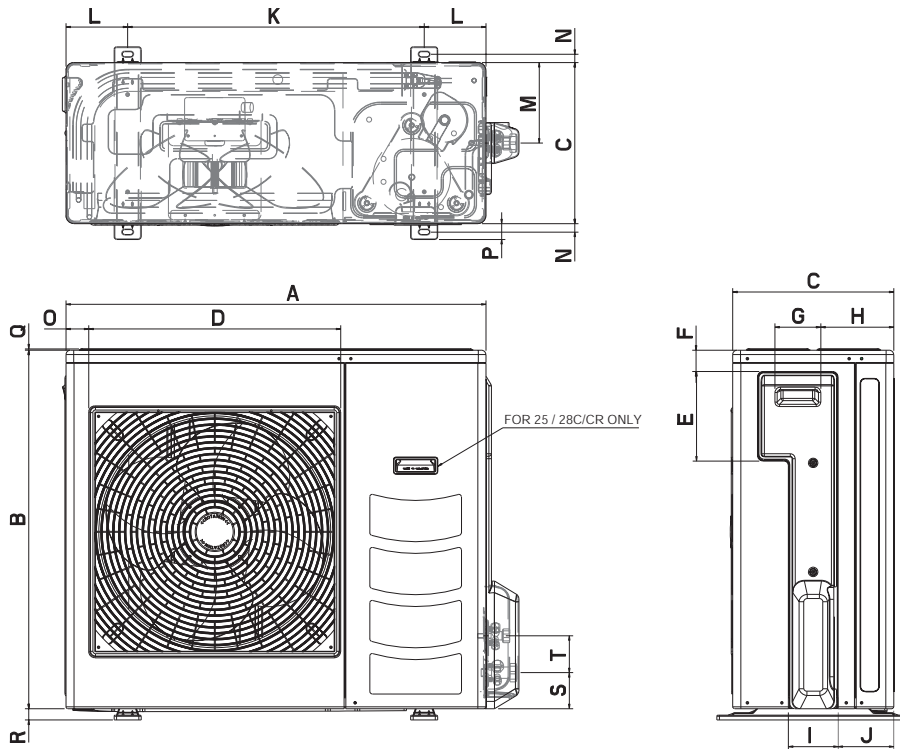

Note : All Dimension in mm

MODEL	A	B	C	D	E	F	G	H	I	J	K	L	M	N	O	P	Q	R	S	T
18C, 20C/CR	855	628	328	508	181	44	93	149	101	113	603	126	164	17	49	32	3	23	73	75
25/28C/CR	855	730	328	513	182	44	93	149	101	113	603	126	164	17	47	32	3	23	73	75

**Model : MLC 030 / 035 / 040 / 050C/CR
M5LC 035 / 040 / 050C/CR**

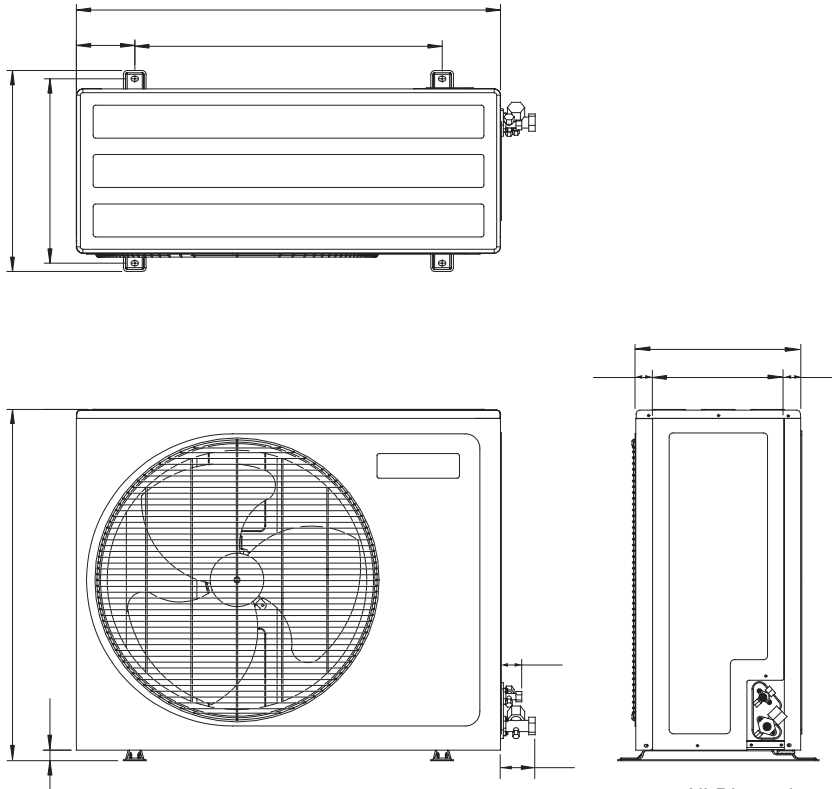

All Dimensions are in mm

Model : MLC / M5LC 061C/CR

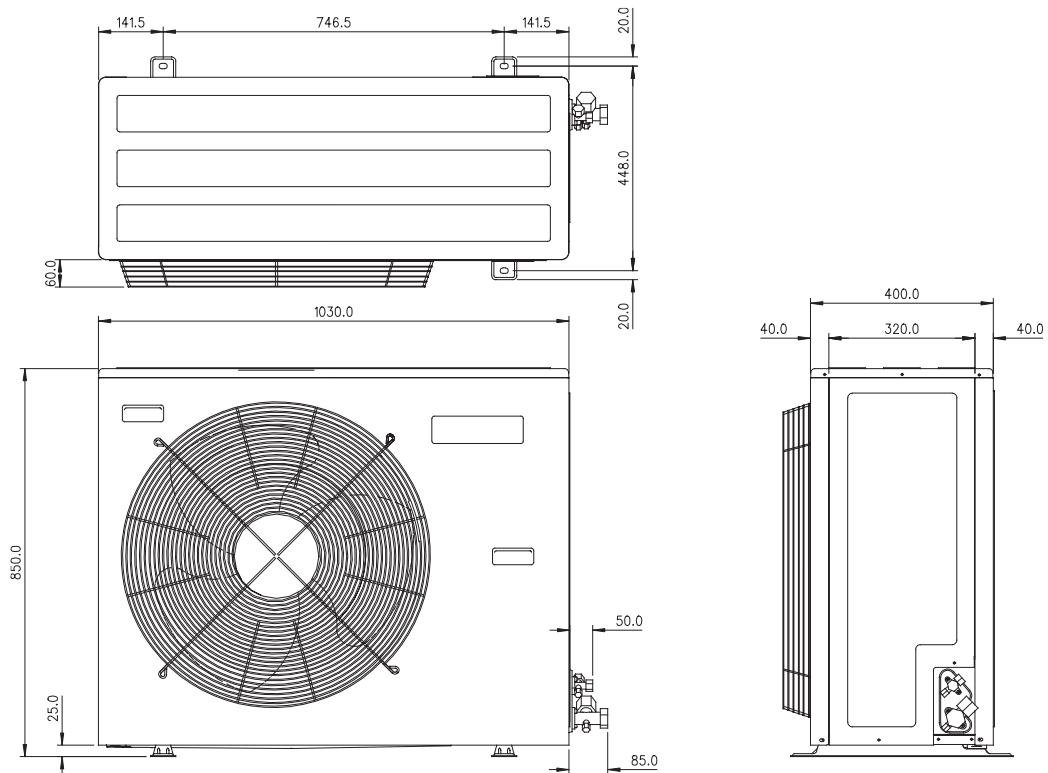

All Dimensions are in mm

Electrical Data

Electrical Data - Cooling Only (R22)

MODEL	INDOOR UNIT		MCC 010C		MCC 015C	
	OUTDOOR UNIT		MLC 010C		MLC 015C	
INDOOR MOTOR	INSULATION GRADE		CLASS E			
	POWER SOURCE	V/Ph/Hz	220 - 240 / 1 / 50			
	RATED INPUT POWER	W	65		96	
	RATED RUNNING CURRENT	A	0.29		0.42	
	MOTOR OUTPUT	W	30		50	
	POLES		4		4	
OUTDOOR MOTOR	INSULATION GRADE		CLASS B			
	POWER SOURCE	V/Ph/Hz	220 - 240 / 1 / 50			
	RATED INPUT POWER	W	52		59	
	RATED RUNNING CURRENT	A	0.23		0.26	
	MOTOR OUTPUT	W	35		35	
	POLES		6		6	
COMPRESSOR	INSULATION GRADE		CLASS E			
	POWER SOURCE	V/Ph/Hz	220 - 240 / 1 / 50			
	CAPACITOR	μF	30.0		30.0	
	RATED INPUT POWER	W	783		1112	
	RATED RUNNING CURRENT	A	3.5		5.0	
	LOCKED ROTOR AMP.	A	19		21	

MODEL	INDOOR UNIT		MCC 020C			
	OUTDOOR UNIT		MLC 018C		MLC 020C	
INDOOR MOTOR	INSULATION GRADE		CLASS E			
	POWER SOURCE	V/Ph/Hz	220 - 240 / 1 / 50			
	RATED INPUT POWER	W	135			
	RATED RUNNING CURRENT	A	0.60			
	MOTOR OUTPUT	W	80			
	POLES		6			
OUTDOOR MOTOR	INSULATION GRADE		CLASS B			
	POWER SOURCE	V/Ph/Hz	220 - 240 / 1 / 50			
	RATED INPUT POWER	W	120			
	RATED RUNNING CURRENT	A	0.53			
	MOTOR OUTPUT	W	55			
	POLES		6			
COMPRESSOR	INSULATION GRADE		CLASS E			
	POWER SOURCE	V/Ph/Hz	220 - 240 / 1 / 50			
	CAPACITOR	μF	60.0		60.0	
	RATED INPUT POWER	W	1655		1640	
	RATED RUNNING CURRENT	A	7.4		7.2	
	LOCKED ROTOR AMP.	A	32		32	

- 1) ALL SPECIFICATIONS ARE SUBJECTED TO CHANGE BY THE MANUFACTURER WITHOUT PRIOR NOTICE.
 2) ALL SPECIFICATIONS ARE BEING TESTED AND COMPLY TO ISO 5151.

Electrical Data - Cooling Only (R22)

MODEL	INDOOR UNIT		MCC 025C
	OUTDOOR UNIT		MLC 025C
INDOOR MOTOR	INSULATION GRADE		CLASS E
	POWER SOURCE	V/Ph/Hz	220 - 240 / 1 / 50
	RATED INPUT POWER	W	152
	RATED RUNNING CURRENT	A	0.67
	MOTOR OUTPUT	W	100
	POLES		4
OUTDOOR MOTOR	INSULATION GRADE		CLASS B
	POWER SOURCE	V/Ph/Hz	220 - 240 / 1 / 50
	RATED INPUT POWER	W	124
	RATED RUNNING CURRENT	A	0.54
	MOTOR OUTPUT	W	55
	POLES		6
COMPRESSOR	INSULATION GRADE		CLASS E
	POWER SOURCE	V/Ph/Hz	220 - 240 / 1 / 50
	CAPACITOR	μF	45.0
	RATED INPUT POWER	W	2340
	RATED RUNNING CURRENT	A	10.49
	LOCKED ROTOR AMP.	A	54

MODEL	INDOOR UNIT		MCC 028C	
	OUTDOOR UNIT		MLC 028C	MLC 030C
INDOOR MOTOR	INSULATION GRADE		CLASS B	
	POWER SOURCE	V/Ph/Hz	220 - 240 / 1 / 50	
	RATED INPUT POWER	W	300	
	RATED RUNNING CURRENT	A	1.30	
	MOTOR OUTPUT	W	320	
	POLES		4	
OUTDOOR MOTOR	INSULATION GRADE		CLASS B	
	POWER SOURCE	V/Ph/Hz	220 - 240 / 1 / 50	
	RATED INPUT POWER	W	142	220
	RATED RUNNING CURRENT	A	0.62	1.02
	MOTOR OUTPUT	W	75	145
	POLES		6	8
COMPRESSOR	INSULATION GRADE		CLASS E	-
	POWER SOURCE - 1Ø / <3Ø>	V/Ph/Hz	220 - 240 / 1 / 50 / <380 - 415 / 3 / 50>	
	CAPACITOR - 1Ø / <3Ø>	μF	50.0	50.0 / <NIL>
	RATED INPUT POWER - 1Ø / <3Ø>	W	2649	2301 / <2461>
	RATED RUNNING CURRENT - 1Ø / <3Ø>	A	13.2	10.6 / <3.4>
	LOCKED ROTOR AMP. - 1Ø / <3Ø>	A	66	82 / <40>

1) ALL SPECIFICATIONS ARE SUBJECTED TO CHANGE BY THE MANUFACTURER WITHOUT PRIOR NOTICE.
 2) ALL SPECIFICATIONS ARE BEING TESTED AND COMPLY TO ISO 5151.

Electrical Data - Cooling Only (R22)

MODEL	INDOOR UNIT		MCC 038C	
	OUTDOOR UNIT		MLC 035C	MLC 040C
INDOOR MOTOR	INSULATION GRADE		CLASS B	
	POWER SOURCE	V/Ph/Hz	220 - 240 / 1 / 50	
	RATED INPUT POWER	W	486	
	RATED RUNNING CURRENT	A	2.10	
	MOTOR OUTPUT	W	470	
	POLES		4	
OUTDOOR MOTOR	INSULATION GRADE		CLASS B	
	POWER SOURCE	V/Ph/Hz	220 - 240 / 1 / 50	
	RATED INPUT POWER	W	220	
	RATED RUNNING CURRENT	A	1.02	
	MOTOR OUTPUT	W	145	
	POLES		8	
COMPRESSOR	INSULATION GRADE		-	-
	POWER SOURCE - 1Ø / <3Ø>	V/Ph/Hz	220 - 240 / 1 / 50 / <380 - 415 / 3 / 50>	
	CAPACITOR - 1Ø / <3Ø>	µF	60.0	60.0 / <NIL>
	RATED INPUT POWER - 1Ø / <3Ø>	W	2737	2767 / <2737>
	RATED RUNNING CURRENT - 1Ø / <3Ø>	A	13.4	24 / <13.4>
	LOCKED ROTOR AMP. - 1Ø / <3Ø>	A	97	114 / <48>

MODEL	INDOOR UNIT		MCC 030C	
	OUTDOOR UNIT		MLC 028C	MLC 030C
INDOOR MOTOR	INSULATION GRADE		CLASS B	
	POWER SOURCE	V/Ph/Hz	220 - 240 / 1 / 50	
	RATED INPUT POWER	W	355	
	RATED RUNNING CURRENT	A	1.57	
	MOTOR OUTPUT	W	320	
	POLES		4	
OUTDOOR MOTOR	INSULATION GRADE		CLASS B	
	POWER SOURCE	V/Ph/Hz	220 - 240 / 1 / 50	
	RATED INPUT POWER	W	142	220
	RATED RUNNING CURRENT	A	0.62	1.02
	MOTOR OUTPUT	W	75	145
	POLES		6	8
COMPRESSOR	INSULATION GRADE		CLASS E	-
	POWER SOURCE - 1Ø / <3Ø>	V/Ph/Hz	220 - 240 / 1 / 50 / <380 - 415 / 3 / 50>	
	CAPACITOR - 1Ø / <3Ø>	µF	50.0	50.0 / <NIL>
	RATED INPUT POWER - 1Ø / <3Ø>	W	2656	2224 / <2294>
	RATED RUNNING CURRENT - 1Ø / <3Ø>	A	13.3	10.5 / <2.9>
	LOCKED ROTOR AMP. - 1Ø / <3Ø>	A	66	82 / <40>

1) ALL SPECIFICATIONS ARE SUBJECTED TO CHANGE BY THE MANUFACTURER WITHOUT PRIOR NOTICE.

2) ALL SPECIFICATIONS ARE BEING TESTED AND COMPLY TO ISO 5151.

Electrical Data - Cooling Only (R22)

MODEL	INDOOR UNIT		MCC 040C	
	OUTDOOR UNIT		MLC 035C	MLC 040C
INDOOR MOTOR	INSULATION GRADE		CLASS B	
	POWER SOURCE	V/Ph/Hz	220 - 240 / 1 / 50	
	RATED INPUT POWER	W	448	
	RATED RUNNING CURRENT	A	1.98	
	MOTOR OUTPUT	W	400	
	POLES		4	
OUTDOOR MOTOR	INSULATION GRADE		CLASS B	
	POWER SOURCE	V/Ph/Hz	220 - 240 / 1 / 50	
	RATED INPUT POWER	W	220	
	RATED RUNNING CURRENT	A	1.02	
	MOTOR OUTPUT	W	145	
	POLES		8	
COMPRESSOR	INSULATION GRADE		-	-
	POWER SOURCE - 1Ø / <3Ø>	V/Ph/Hz	220 - 240 / 1 / 50 / <380 - 415 / 3 / 50>	
	CAPACITOR - 1Ø / <3Ø>	µF	60.0	60.0 / <NIL>
	RATED INPUT POWER - 1Ø / <3Ø>	W	2737	2887 / <2837>
	RATED RUNNING CURRENT - 1Ø / <3Ø>	A	13.4	15.5 / <4.9>
	LOCKED ROTOR AMP. - 1Ø / <3Ø>	A	97	114 / <48>

MODEL	INDOOR UNIT		MCC 050C	MCC 060C
	OUTDOOR UNIT		MLC 050C	MLC 061C
INDOOR MOTOR	INSULATION GRADE		CLASS B	
	POWER SOURCE	V/Ph/Hz	220 - 240 / 1 / 50	
	RATED INPUT POWER	W	510	748
	RATED RUNNING CURRENT	A	2.26	3.20
	MOTOR OUTPUT	W	480	600
	POLES		4	4
OUTDOOR MOTOR	INSULATION GRADE		CLASS B	CLASS F
	POWER SOURCE	V/Ph/Hz	220 - 240 / 1 / 50	
	RATED INPUT POWER	W	220	258
	RATED RUNNING CURRENT	A	1.02	1.20
	MOTOR OUTPUT	W	145	400
	POLES		8	8
COMPRESSOR	INSULATION GRADE		-	-
	POWER SOURCE	V/Ph/Hz	380 - 415 / 3 / 50	
	CAPACITOR	µF	NIL	NIL
	RATED INPUT POWER	W	4244	5000
	RATED RUNNING CURRENT	A	7.50	8.50
	LOCKED ROTOR AMP.	A	66	74

1) ALL SPECIFICATIONS ARE SUBJECTED TO CHANGE BY THE MANUFACTURER WITHOUT PRIOR NOTICE.

2) ALL SPECIFICATIONS ARE BEING TESTED AND COMPLY TO ISO 5151.

Electrical Data - Heat pump (R22)

MODEL	INDOOR UNIT		MCC 010CR		MCC 015CR	
	OUTDOOR UNIT		MLC 010CR		MLC 015CR	
INDOOR MOTOR	INSULATION GRADE		CLASS E			
	POWER SOURCE	V/Ph/Hz	220 - 240 / 1 / 50			
	RATED INPUT POWER	W	65		96	
	RATED RUNNING CURRENT	A	0.29		0.42	
	MOTOR OUTPUT	W	30		50	
	POLES		4		4	
OUTDOOR MOTOR	INSULATION GRADE		CLASS B			
	POWER SOURCE	V/Ph/Hz	220 - 240 / 1 / 50			
	RATED INPUT POWER	W	52		59	
	RATED RUNNING CURRENT	A	0.23		0.26	
	MOTOR OUTPUT	W	35		35	
	POLES		6		6	
COMPRESSOR	INSULATION GRADE		CLASS E			
	POWER SOURCE	V/Ph/Hz	220 - 240 / 1 / 50			
	CAPACITOR	μF	30.0		30.0	
	RATED INPUT POWER (COOLING)	W	783		1112	
	RATED INPUT POWER (HEATING)	W	673		907	
	RATED RUNNING CURRENT (COOLING)	A	3.5		5.0	
	RATED RUNNING CURRENT (HEATING)	A	3.0		4.1	
	LOCKED ROTOR AMP.	A	19		21	

MODEL	INDOOR UNIT		MCC 020CR			
	OUTDOOR UNIT		MLC 018CR		MLC 020CR	
INDOOR MOTOR	INSULATION GRADE		CLASS E			
	POWER SOURCE	V/Ph/Hz	220 - 240 / 1 / 50			
	RATED INPUT POWER	W	135			
	RATED RUNNING CURRENT	A	0.60			
	MOTOR OUTPUT	W	80			
	POLES		6			
OUTDOOR MOTOR	INSULATION GRADE		CLASS B			
	POWER SOURCE	V/Ph/Hz	220 - 240 / 1 / 50			
	RATED INPUT POWER	W	120			
	RATED RUNNING CURRENT	A	0.53			
	MOTOR OUTPUT	W	55			
	POLES		6			
COMPRESSOR	INSULATION GRADE		CLASS E			
	POWER SOURCE	V/Ph/Hz	220 - 240 / 1 / 50			
	CAPACITOR	μF	60.0		60.0	
	RATED INPUT POWER (COOLING)	W	1655		1640	
	RATED INPUT POWER (HEATING)	W	1495		1590	
	RATED RUNNING CURRENT (COOLING)	A	7.4		7.2	
	RATED RUNNING CURRENT (HEATING)	A	6.7		7.0	
	LOCKED ROTOR AMP.	A	32		32	

- 1) ALL SPECIFICATIONS ARE SUBJECTED TO CHANGE BY THE MANUFACTURER WITHOUT PRIOR NOTICE.
2) ALL SPECIFICATIONS ARE BEING TESTED AND COMPLY TO ISO 5151.

Electrical Data - Heat Pump (R22)

MODEL	INDOOR UNIT		MCC 025CR	
	OUTDOOR UNIT		MLC 025CR	
INDOOR MOTOR	INSULATION GRADE		CLASS E	
	POWER SOURCE	V/Ph/Hz	220 - 240 / 1 / 50	
	RATED INPUT POWER	W	152	
	RATED RUNNING CURRENT	A	0.67	
	MOTOR OUTPUT	W	100	
	POLES		4	
OUTDOOR MOTOR	INSULATION GRADE		CLASS B	
	POWER SOURCE	V/Ph/Hz	220 - 240 / 1 / 50	
	RATED INPUT POWER	W	124	
	RATED RUNNING CURRENT	A	0.54	
	MOTOR OUTPUT	W	55	
	POLES		6	
COMPRESSOR	INSULATION GRADE		CLASS E	
	POWER SOURCE	V/Ph/Hz	220 - 240 / 1 / 50	
	CAPACITOR	μF	50.0	
	RATED INPUT POWER (COOLING)	W	2340	
	RATED INPUT POWER (HEATING)	W	2260	
	RATED RUNNING CURRENT (COOLING)	A	10.49	
	RATED RUNNING CURRENT (HEATING)	A	10.24	
	LOCKED ROTOR AMP.	A	54	

MODEL	INDOOR UNIT		MCC 028CR	
	OUTDOOR UNIT		MLC 028CR	MLC 030CR
INDOOR MOTOR	INSULATION GRADE		CLASS B	
	POWER SOURCE	V/Ph/Hz	220 - 240 / 1 / 50	
	RATED INPUT POWER	W	300	
	RATED RUNNING CURRENT	A	1.30	
	MOTOR OUTPUT	W	320	
	POLES		4	
OUTDOOR MOTOR	INSULATION GRADE		CLASS B	
	POWER SOURCE	V/Ph/Hz	220 - 240 / 1 / 50	
	RATED INPUT POWER	W	142	220
	RATED RUNNING CURRENT	A	0.62	1.02
	MOTOR OUTPUT	W	75	145
	POLES		6	8
COMPRESSOR	INSULATION GRADE		CLASS E	-
	POWER SOURCE - 1Ø / <3Ø>	V/Ph/Hz	220 - 240 / 1 / 50 / <380 - 415 / 3 / 50>	
	CAPACITOR - 1Ø / <3Ø>	μF	50.0	50.0 / <NIL>
	RATED INPUT POWER (COOLING) - 1Ø / <3Ø>	W	2649	2570 / <2550>
	RATED INPUT POWER (HEATING) - 1Ø / <3Ø>	W	2196	2540 / <2520>
	RATED RUNNING CURRENT (COOLING) - 1Ø / <3Ø>	A	13.2	12.4 / <4.3>
	RATED RUNNING CURRENT (HEATING) - 1Ø / <3Ø>	A	11.5	12.3 / <4.2>
	LOCKED ROTOR AMP. - 1Ø / <3Ø>	A	66	82 / <40>

- 1) ALL SPECIFICATIONS ARE SUBJECTED TO CHANGE BY THE MANUFACTURER WITHOUT PRIOR NOTICE.
 2) ALL SPECIFICATIONS ARE BEING TESTED AND COMPLY TO ISO 5151.

Electrical Data - Heat Pump (R22)

MODEL	INDOOR UNIT		MCC 038CR	
	OUTDOOR UNIT		MLC 035CR	MLC 040CR
INDOOR MOTOR	INSULATION GRADE		CLASS B	
	POWER SOURCE	V/Ph/Hz	220 - 240 / 1 / 50	
	RATED INPUT POWER	W	486	
	RATED RUNNING CURRENT	A	2.10	
	MOTOR OUTPUT	W	470	
	POLES		4	
OUTDOOR MOTOR	INSULATION GRADE		CLASS B	
	POWER SOURCE	V/Ph/Hz	220 - 240 / 1 / 50	
	RATED INPUT POWER	W	220	
	RATED RUNNING CURRENT	A	1.02	
	MOTOR OUTPUT	W	145	
	POLES		8	
COMPRESSOR	INSULATION GRADE		-	-
	POWER SOURCE - 1Ø / <3Ø>	V/Ph/Hz	220 - 240 / 1 / 50 / <380 - 415 / 3 / 50>	
	CAPACITOR - 1Ø / <3Ø>	µF	60.0	60.0 / <NIL>
	RATED INPUT POWER (COOLING) - 1Ø / <3Ø>	W	2597	3060 / <3030>
	RATED INPUT POWER (HEATING) - 1Ø / <3Ø>	W	2597	2770 / <2740>
	RATED RUNNING CURRENT (COOLING) - 1Ø / <3Ø>	A	13.40	15.0 / <4.4>
	RATED RUNNING CURRENT (HEATING) - 1Ø / <3Ø>	A	13.40	13.6 / <3.0>
	LOCKED ROTOR AMP. - 1Ø / <3Ø>	A	97	114 / <48>

MODEL	INDOOR UNIT		MCC 030CR	
	OUTDOOR UNIT		MLC 028CR	MLC 030CR
INDOOR MOTOR	INSULATION GRADE		CLASS B	
	POWER SOURCE	V/Ph/Hz	220 - 240 / 1 / 50	
	RATED INPUT POWER	W	355	
	RATED RUNNING CURRENT	A	1.57	
	MOTOR OUTPUT	W	320	
	POLES		4	
OUTDOOR MOTOR	INSULATION GRADE		CLASS B	
	POWER SOURCE	V/Ph/Hz	220 - 240 / 1 / 50	
	RATED INPUT POWER	W	142	220
	RATED RUNNING CURRENT	A	0.62	1.02
	MOTOR OUTPUT	W	75	145
	POLES		6	8
COMPRESSOR	INSULATION GRADE		CLASS E	-
	POWER SOURCE - 1Ø / <3Ø>	V/Ph/Hz	220 - 240 / 1 / 50 / <380 - 415 / 3 / 50>	
	CAPACITOR - 1Ø / <3Ø>	µF	50.0	50.0 / <NIL>
	RATED INPUT POWER (COOLING) - 1Ø / <3Ø>	W	2656	2570 / <2550>
	RATED INPUT POWER (HEATING) - 1Ø / <3Ø>	W	2232	2540 / <2520>
	RATED RUNNING CURRENT (COOLING) - 1Ø / <3Ø>	A	13.3	12.4 / <4.3>
	RATED RUNNING CURRENT (HEATING) - 1Ø / <3Ø>	A	11.6	12.3 / <4.2>
	LOCKED ROTOR AMP. - 1Ø / <3Ø>	A	66	82 / <40>

- 1) ALL SPECIFICATIONS ARE SUBJECTED TO CHANGE BY THE MANUFACTURER WITHOUT PRIOR NOTICE.
2) ALL SPECIFICATIONS ARE BEING TESTED AND COMPLY TO ISO 5151.

Electrical Data - Heat Pump (R22)

MODEL	INDOOR UNIT		MCC 040CR	
	OUTDOOR UNIT		MLC 035CR	MLC 040CR
INDOOR MOTOR	INSULATION GRADE		CLASS B	
	POWER SOURCE	V/Ph/Hz	220 - 240 / 1 / 50	
	RATED INPUT POWER	W	448	
	RATED RUNNING CURRENT	A	1.98	
	MOTOR OUTPUT	W	400	
	POLES		4	
OUTDOOR MOTOR	INSULATION GRADE		CLASS B	
	POWER SOURCE	V/Ph/Hz	220 - 240 / 1 / 50	
	RATED INPUT POWER	W	220	
	RATED RUNNING CURRENT	A	1.02	
	MOTOR OUTPUT	W	145	
	POLES		8	
COMPRESSOR	INSULATION GRADE		-	-
	POWER SOURCE - 1Ø / <3Ø>	V/Ph/Hz	220 - 240 / 1 / 50 / <380 - 415 / 3 / 50>	
	CAPACITOR - 1Ø / <3Ø>	µF	60.0	60.0 / <NIL>
	RATED INPUT POWER (COOLING) - 1Ø / <3Ø>	W	2597	3060 / <3030>
	RATED INPUT POWER (HEATING) - 1Ø / <3Ø>	W	2597	2770 / <2740>
	RATED RUNNING CURRENT (COOLING) - 1Ø / <3Ø>	A	13.40	15.0 / <4.4>
	RATED RUNNING CURRENT (HEATING) - 1Ø / <3Ø>	A	13.40	13.6 / <3.0>
	LOCKED ROTOR AMP. - 1Ø / <3Ø>	A	97	114 / <48>

MODEL	INDOOR UNIT		MCC 050CR	MCC 060CR
	OUTDOOR UNIT		MLC 050CR	MLC 061CR
INDOOR MOTOR	INSULATION GRADE		CLASS B	
	POWER SOURCE	V/Ph/Hz	220 - 240 / 1 / 50	
	RATED INPUT POWER	W	510	748
	RATED RUNNING CURRENT	A	2.26	3.20
	MOTOR OUTPUT	W	480	600
	POLES		4	4
OUTDOOR MOTOR	INSULATION GRADE		CLASS B	CLASS F
	POWER SOURCE	V/Ph/Hz	220 - 240 / 1 / 50	
	RATED INPUT POWER	W	220	258
	RATED RUNNING CURRENT	A	1.02	1.20
	MOTOR OUTPUT	W	145	400
	POLES		8	8
COMPRESSOR	INSULATION GRADE		-	-
	POWER SOURCE	V/Ph/Hz	380 - 415 / 3 / 50	
	CAPACITOR	µF	NIL	NIL
	RATED INPUT POWER (COOLING)	W	4317	5000
	RATED INPUT POWER (HEATING)	W	3717	3970
	RATED RUNNING CURRENT (COOLING)	A	7.9	8.5
	RATED RUNNING CURRENT (HEATING)	A	4.9	7.3
	LOCKED ROTOR AMP.	A	66	74

- 1) ALL SPECIFICATIONS ARE SUBJECTED TO CHANGE BY THE MANUFACTURER WITHOUT PRIOR NOTICE.
2) ALL SPECIFICATIONS ARE BEING TESTED AND COMPLY TO ISO 5151.

Electrical Data - Cooling Only (R410A)

MODEL	INDOOR UNIT		M5CC 010C	M5CC 015C
	OUTDOOR UNIT		M5LC 010C	M5LC 015C
INDOOR MOTOR	INSULATION GRADE		CLASS E	
	POWER SOURCE	V/Ph/Hz	220 - 240 / 1 / 50	
	RATED INPUT POWER	W	65	96
	RATED RUNNING CURRENT	A	0.29	0.42
	MOTOR OUTPUT	W	30	50
	POLES		4	4
OUTDOOR MOTOR	INSULATION GRADE		CLASS B	
	POWER SOURCE	V/Ph/Hz	220 - 240 / 1 / 50	
	RATED INPUT POWER	W	52	59
	RATED RUNNING CURRENT	A	0.23	0.26
	MOTOR OUTPUT	W	35	35
	POLES		6	6
COMPRESSOR	INSULATION GRADE		CLASS E	
	POWER SOURCE	V/Ph/Hz	220 - 240 / 1 / 50	
	CAPACITOR	μF	25.0	35.0
	RATED INPUT POWER	W	844	1142
	RATED RUNNING CURRENT	A	3.5	5.0
	LOCKED ROTOR AMP.	A	19	24

MODEL	INDOOR UNIT		M5CC 020C	M5CC 025C
	OUTDOOR UNIT		M5LC 020C	M5LC 025C
INDOOR MOTOR	INSULATION GRADE		CLASS E	
	POWER SOURCE	V/Ph/Hz	220 - 240 / 1 / 50	
	RATED INPUT POWER	W	135	152
	RATED RUNNING CURRENT	A	0.60	0.67
	MOTOR OUTPUT	W	80	100
	POLES		4	4
OUTDOOR MOTOR	INSULATION GRADE		CLASS B	
	POWER SOURCE	V/Ph/Hz	220 - 240 / 1 / 50	
	RATED INPUT POWER	W	117	132
	RATED RUNNING CURRENT	A	0.51	0.58
	MOTOR OUTPUT	W	64	64
	POLES		6	6
COMPRESSOR	INSULATION GRADE		CLASS E	
	POWER SOURCE - 1Ø / <3Ø>	V/Ph/Hz	220 - 240 / 1 / 50 / <380 - 415 / 3 / 50>	
	CAPACITOR - 1Ø / <3Ø>	μF	50.0 / <NIL>	50.0 / <NIL>
	RATED INPUT POWER - 1Ø / <3Ø>	W	1505 / <1536>	1719 / <1990>
	RATED RUNNING CURRENT - 1Ø / <3Ø>	A	6.5 / <3.0>	7.6 / <3.8>
	LOCKED ROTOR AMP. - 1Ø / <3Ø>	A	27 / <19>	63 / <26>

- 1) ALL SPECIFICATIONS ARE SUBJECTED TO CHANGE BY THE MANUFACTURER WITHOUT PRIOR NOTICE.
 2) ALL SPECIFICATIONS ARE BEING TESTED AND COMPLY TO ISO 5151.

Electrical Data - Cooling Only (R410A)

MODEL	INDOOR UNIT		M5CC 028C	
	OUTDOOR UNIT		M5LC 028C	M5LC 035C
INDOOR MOTOR	INSULATION GRADE		CLASS B	
	POWER SOURCE	V/Ph/Hz	220 - 240 / 1 / 50	
	RATED INPUT POWER	W	300	
	RATED RUNNING CURRENT	A	1.30	
	MOTOR OUTPUT	W	320	
	POLES		4	
OUTDOOR MOTOR	INSULATION GRADE		CLASS B	
	POWER SOURCE	V/Ph/Hz	220 - 240 / 1 / 50	
	RATED INPUT POWER	W	142	220
	RATED RUNNING CURRENT	A	0.62	1.02
	MOTOR OUTPUT	W	75	145
	POLES		6	8
COMPRESSOR	INSULATION GRADE		E CLASS	N/A
	POWER SOURCE - 1Ø / <3Ø>	V/Ph/Hz	220 - 240 / 1 / 50 / <380 / 3 / 50>	
	CAPACITOR - 1Ø / <3Ø>	µF	50.0 / <NIL>	60.0 / <NIL>
	RATED INPUT POWER - 1Ø / <3Ø>	W	2450 / <2434>	2547 / <2432>
	RATED RUNNING CURRENT - 1Ø / <3Ø>	A	10.9 / <4.3>	12.7 / <12.2>
	LOCKED ROTOR AMP. - 1Ø / <3Ø>	A	65 / <26>	82 / <48>

MODEL	INDOOR UNIT		M5CC 038C	
	OUTDOOR UNIT		M5LC 040C	
INDOOR MOTOR	INSULATION GRADE		CLASS B	
	POWER SOURCE	V/Ph/Hz	220 - 240 / 1 / 50	
	RATED INPUT POWER	W	503	
	RATED RUNNING CURRENT	A	2.27	
	MOTOR OUTPUT	W	470	
	POLES		4	
OUTDOOR MOTOR	INSULATION GRADE		CLASS B	
	POWER SOURCE	V/Ph/Hz	220 - 240 / 1 / 50	
	RATED INPUT POWER	W	220	
	RATED RUNNING CURRENT	A	1.02	
	MOTOR OUTPUT	W	145	
	POLES		8	
COMPRESSOR	INSULATION GRADE		-	
	POWER SOURCE	V/Ph/Hz	380 - 415 / 3 / 50	
	CAPACITOR	µF	NIL	
	RATED INPUT POWER	W	3484	
	RATED RUNNING CURRENT	A	6.2	
	LOCKED ROTOR AMP.	A	64	

- 1) ALL SPECIFICATIONS ARE SUBJECTED TO CHANGE BY THE MANUFACTURER WITHOUT PRIOR NOTICE.
 2) ALL SPECIFICATIONS ARE BEING TESTED AND COMPLY TO ARI210/240-94.

Electrical Data - Cooling Only (R410A)

MODEL	INDOOR UNIT		M5CC 050C	M5CC 060C
	OUTDOOR UNIT		M5LC 050C	M5LC 061C
INDOOR MOTOR	INSULATION GRADE		CLASS B	
	POWER SOURCE	V/Ph/Hz	220 - 240 / 1 / 50	
	RATED INPUT POWER	W	515	659
	RATED RUNNING CURRENT	A	2.32	2.91
	MOTOR OUTPUT	W	480	600
	POLES		4	4
OUTDOOR MOTOR	INSULATION GRADE		CLASS B	
	POWER SOURCE	V/Ph/Hz	220 - 240 / 1 / 50	
	RATED INPUT POWER	W	575	575
	RATED RUNNING CURRENT	A	2.54	2.54
	MOTOR OUTPUT	W	400	400
	POLES		6	6
COMPRESSOR	INSULATION GRADE		-	-
	POWER SOURCE	V/Ph/Hz	380 - 415 / 3 / 50	
	CAPACITOR	μF	NIL	NIL
	RATED INPUT POWER	W	4021	4524
	RATED RUNNING CURRENT	A	7.3	7.9
	LOCKED ROTOR AMP.	A	74	74

1) ALL SPECIFICATIONS ARE SUBJECTED TO CHANGE BY THE MANUFACTURER WITHOUT PRIOR NOTICE.

2) ALL SPECIFICATIONS ARE BEING TESTED AND COMPLY TO AR1210/240-94.

Electrical Data - Heat pump (R410A)

MODEL	INDOOR UNIT		M5CC 010CR	M5CC 015CR
	OUTDOOR UNIT		M5LC 010CR	M5LC 015CR
INDOOR MOTOR	INSULATION GRADE		CLASS E	
	POWER SOURCE	V/Ph/Hz	220 - 240 / 1 / 50	
	RATED INPUT POWER	W	65	96
	RATED RUNNING CURRENT	A	0.29	0.42
	MOTOR OUTPUT	W	30	50
	POLES		4	4
OUTDOOR MOTOR	INSULATION GRADE		CLASS B	
	POWER SOURCE	V/Ph/Hz	220 - 240 / 1 / 50	
	RATED INPUT POWER	W	52	59
	RATED RUNNING CURRENT	A	0.23	0.26
	MOTOR OUTPUT	W	35	35
	POLES		6	6
COMPRESSOR	INSULATION GRADE		CLASS E	
	POWER SOURCE	V/Ph/Hz	220 - 240 / 1 / 50	
	CAPACITOR	μF	25.0	35.0
	RATED INPUT POWER (COOLING)	W	844	1142
	RATED INPUT POWER (HEATING)	W	696	992
	RATED RUNNING CURRENT (COOLING)	A	3.8	5.0
	RATED RUNNING CURRENT (HEATING)	A	3.2	4.5
	LOCKED ROTOR AMP.	A	19	24

MODEL	INDOOR UNIT		M5CC 020CR	M5CC 025CR
	OUTDOOR UNIT		M5LC 020CR	M5LC 025CR
INDOOR MOTOR	INSULATION GRADE		CLASS E	
	POWER SOURCE	V/Ph/Hz	220 - 240 / 1 / 50	
	RATED INPUT POWER	W	135	152
	RATED RUNNING CURRENT	A	0.60	0.67
	MOTOR OUTPUT	W	80	100
	POLES		4	4
OUTDOOR MOTOR	INSULATION GRADE		CLASS B	
	POWER SOURCE	V/Ph/Hz	220 - 240 / 1 / 50	
	RATED INPUT POWER	W	117	132
	RATED RUNNING CURRENT	A	0.51	0.58
	MOTOR OUTPUT	W	64	64
	POLES		6	6
COMPRESSOR	INSULATION GRADE		CLASS E	
	POWER SOURCE - 1Ø / <3Ø>	V/Ph/Hz	220 - 240 / 1 / 50 / <380 - 415 / 3 / 50>	
	CAPACITOR - 1Ø / <3Ø>	μF	50.0 / <NIL>	50.0 / <NIL>
	RATED INPUT POWER (COOLING) - 1Ø / <3Ø>	W	1505 / <1536>	1719 / <1990>
	RATED INPUT POWER (HEATING) - 1Ø / <3Ø>	W	1345 / <1306>	1669 / <1883>
	RATED RUNNING CURRENT (COOLING) - 1Ø / <3Ø>	A	6.5 / <3.0>	7.6 / <3.8>
	RATED RUNNING CURRENT (HEATING) - 1Ø / <3Ø>	A	6.3 / <2.5>	7.5 / <3.6>
	LOCKED ROTOR AMP. - 1Ø / <3Ø>	A	27 / <19>	63 / <26>

- 1) ALL SPECIFICATIONS ARE SUBJECTED TO CHANGE BY THE MANUFACTURER WITHOUT PRIOR NOTICE.
2) ALL SPECIFICATIONS ARE BEING TESTED AND COMPLY TO ARI210/240-94.

Electrical Data - Heat pump (R410A)

MODEL	INDOOR UNIT		M5CC 028CR	
	OUTDOOR UNIT		M5LC 028CR	M5LC 035CR
INDOOR MOTOR	INSULATION GRADE		CLASS B	
	POWER SOURCE	V/Ph/Hz	220 - 240 / 1 / 50	
	RATED INPUT POWER	W	300	
	RATED RUNNING CURRENT	A	1.30	
	MOTOR OUTPUT	W	320	
	POLES		4	
OUTDOOR MOTOR	INSULATION GRADE		CLASS B	
	POWER SOURCE	V/Ph/Hz	220 - 240 / 1 / 50	
	RATED INPUT POWER	W	142	220
	RATED RUNNING CURRENT	A	0.62	1.06
	MOTOR OUTPUT	W	75	145
	POLES		6	8
COMPRESSOR	INSULATION GRADE		CLASS E	N/A
	POWER SOURCE - 1Ø / <3Ø>	V/Ph/Hz	220 - 240 / 1 / 50 / <380 - 415 / 3 / 50>	
	CAPACITOR - 1Ø / <3Ø>	µF	50.0 / <NIL>	60.0 / <NIL>
	RATED INPUT POWER (COOLING) - 1Ø / <3Ø>	W	2450 / <2434>	2547 / <2432>
	RATED INPUT POWER (HEATING) - 1Ø / <3Ø>	W	1987 / <2086>	2407 / <1925>
	RATED RUNNING CURRENT (COOLING) - 1Ø / <3Ø>	A	10.9 / <4.3>	12.7 / <12.2>
	RATED RUNNING CURRENT (HEATING) - 1Ø / <3Ø>	A	9.3 / <3.9>	11.7 / <10.6>
	LOCKED ROTOR AMP. - 1Ø / <3Ø>	A	65 / <26>	82 / <48>

MODEL	INDOOR UNIT		M5CC 038CR	
	OUTDOOR UNIT		M5LC 040CR	
INDOOR MOTOR	INSULATION GRADE		CLASS B	
	POWER SOURCE	V/Ph/Hz	220 - 240 / 1 / 50	
	RATED INPUT POWER	W	503	
	RATED RUNNING CURRENT	A	2.27	
	MOTOR OUTPUT	W	470	
	POLES		4	
OUTDOOR MOTOR	INSULATION GRADE		CLASS B	
	POWER SOURCE	V/Ph/Hz	220 - 240 / 1 / 50	
	RATED INPUT POWER	W	220	
	RATED RUNNING CURRENT	A	1.02	
	MOTOR OUTPUT	W	145	
	POLES		8	
COMPRESSOR	INSULATION GRADE		-	
	POWER SOURCE	V/Ph/Hz	380 - 415 / 3 / 50	
	CAPACITOR	µF	NIL	
	RATED INPUT POWER (COOLING)	W	3484	
	RATED INPUT POWER (HEATING)	W	3514	
	RATED RUNNING CURRENT (COOLING)	A	6.2	
	RATED RUNNING CURRENT (HEATING)	A	6.3	
LOCKED ROTOR AMP.	A	64		

- 1) ALL SPECIFICATIONS ARE SUBJECTED TO CHANGE BY THE MANUFACTURER WITHOUT PRIOR NOTICE.
2) ALL UNITS ARE BEING TESTED AND COMPLY TO ARI210/240-94.

Electrical Data - Heat pump (R410A)

MODEL	INDOOR UNIT		M5CC 050CR	M5CC 060CR
	OUTDOOR UNIT		M5LC 050CR	M5LC 061CR
INDOOR MOTOR	INSULATION GRADE		CLASS B	
	POWER SOURCE	V/Ph/Hz	220 - 240 / 1 / 50	
	RATED INPUT POWER	W	515	659
	RATED RUNNING CURRENT	A	2.32	2.91
	MOTOR OUTPUT	W	480	600
	POLES		4	4
OUTDOOR MOTOR	INSULATION GRADE		CLASS B	
	POWER SOURCE	V/Ph/Hz	220 - 240 / 1 / 50	
	RATED INPUT POWER	W	575	575
	RATED RUNNING CURRENT	A	2.54	2.54
	MOTOR OUTPUT	W	400	400
	POLES		6	6
COMPRESSOR	INSULATION GRADE		-	-
	POWER SOURCE	V/Ph/Hz	380 - 415 / 3 / 50	
	CAPACITOR	μF	NIL	NIL
	RATED INPUT POWER (COOLING)	W	4021	4524
	RATED INPUT POWER (HEATING)	W	3441	4444
	RATED RUNNING CURRENT (COOLING)	A	7.3	7.9
	RATED RUNNING CURRENT (HEATING)	A	6.6	7.9
	LOCKED ROTOR AMP.	A	74	74

- 1) ALL SPECIFICATIONS ARE SUBJECTED TO CHANGE BY THE MANUFACTURER WITHOUT PRIOR NOTICE.
 2) ALL UNITS ARE BEING TESTED AND COMPLY TO ARI210/240-94.

Wiring Diagrams

Cooling only

Indoor Unit

Model : MCC / M5CC 010C, M5CC 015C

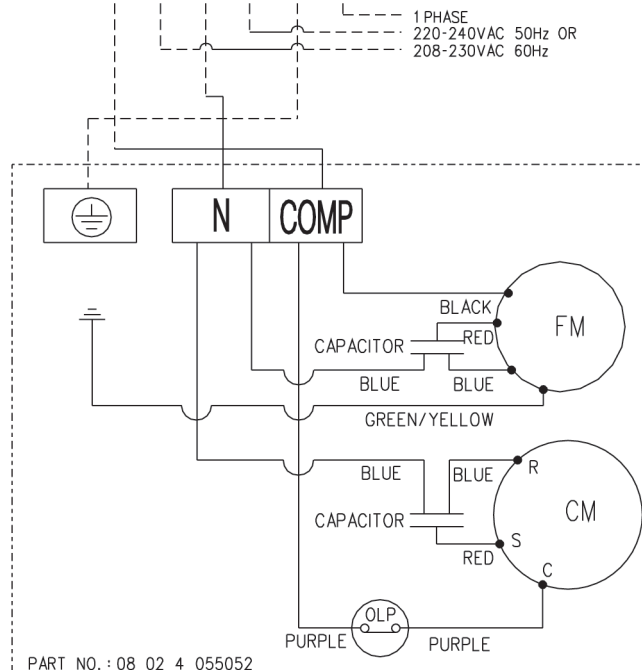
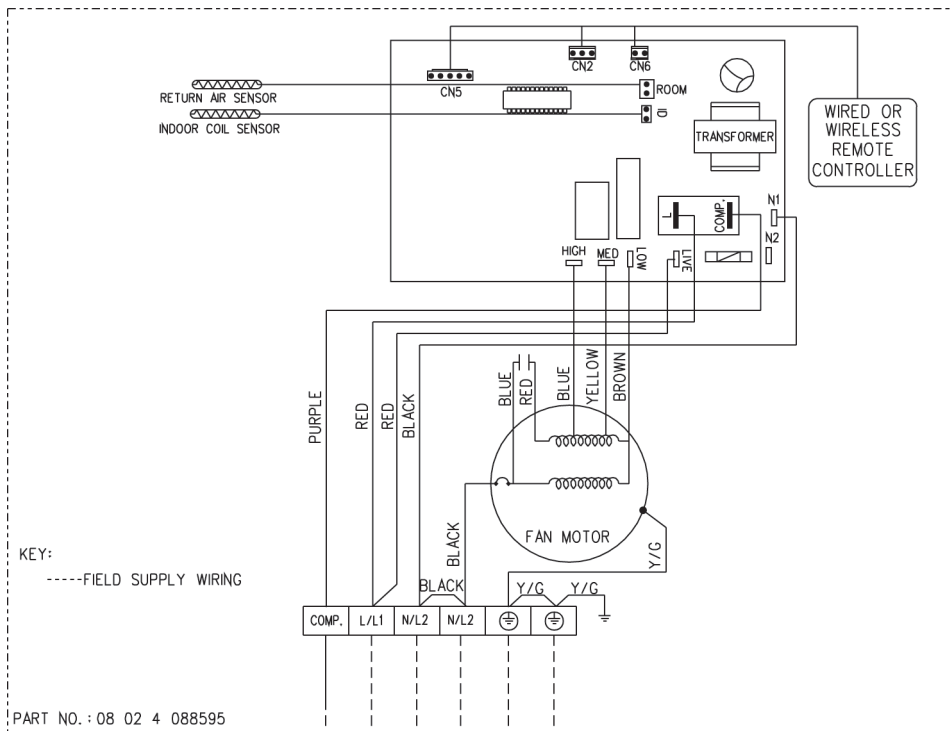

Outdoor Unit

Model : MLC / M5LC 010, M5LC 015C

**Indoor Unit
Model : MCC 015C**

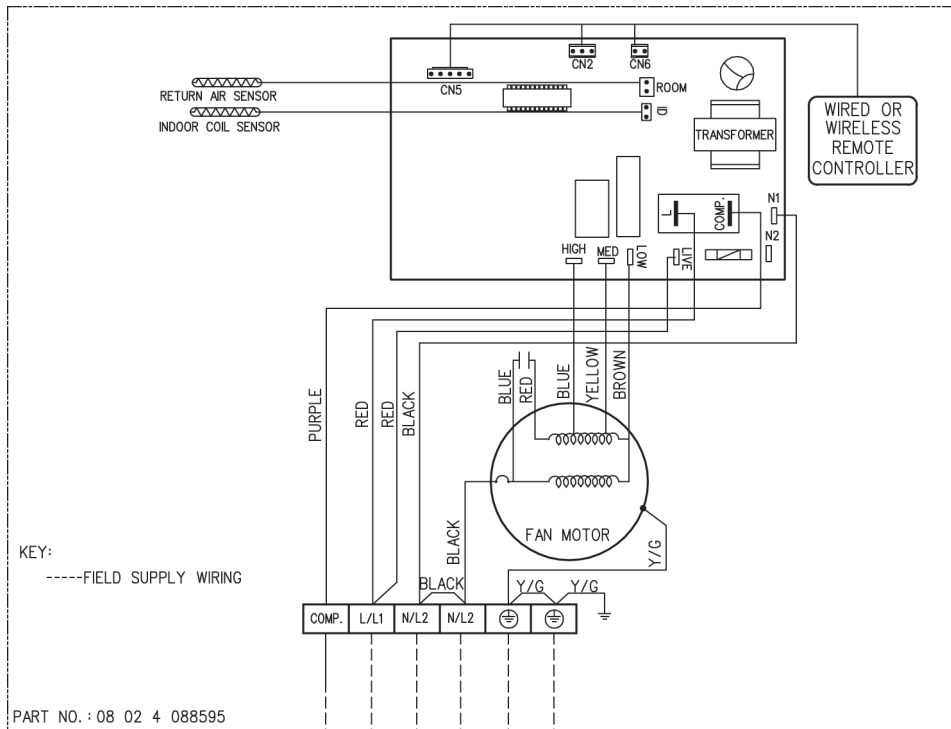

1 PHASE
220-240VAC 50Hz OR
208-230VAC 60Hz

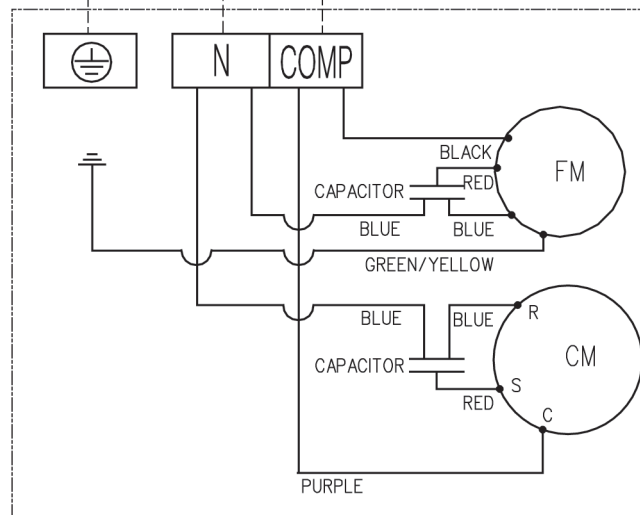

**Outdoor Unit
Model : MLC 015C**

Indoor Unit
Model : MCC / M5CC 020 / 025C

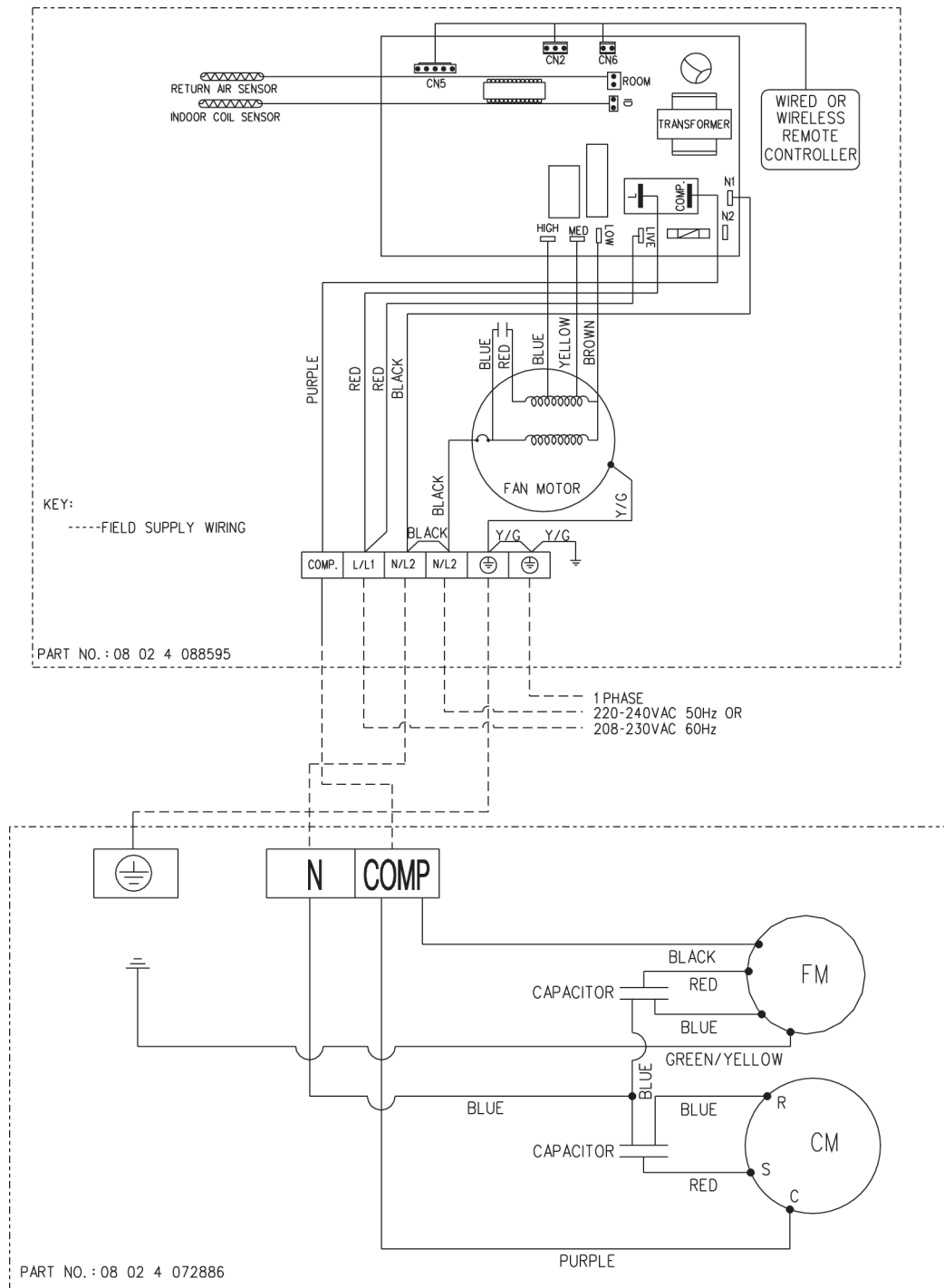

Outdoor Unit
Model : MLC / M5LC 020 / 025C, MLC 018C

Indoor Unit
Model : MCC / M5CC 028C, MCC 030C

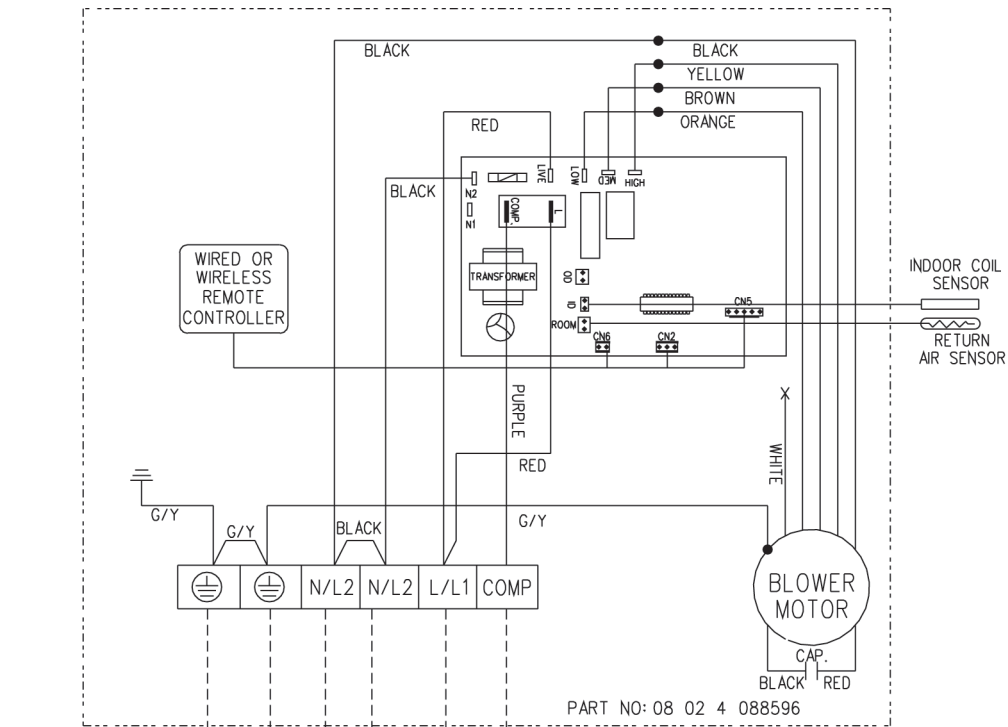

1 PHASE
 220~415VAC 50Hz OR
 208~230VAC 60Hz

E
 L
 N

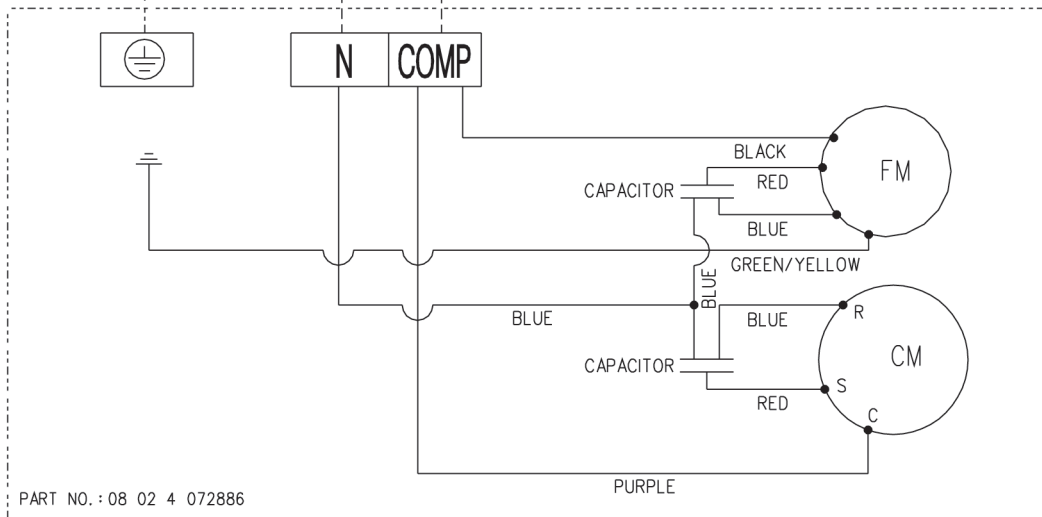

Outdoor Unit
Model : MLC/ M5LC 028C

Indoor Unit
Model : MCC 028 / 030C, M5CC 028C

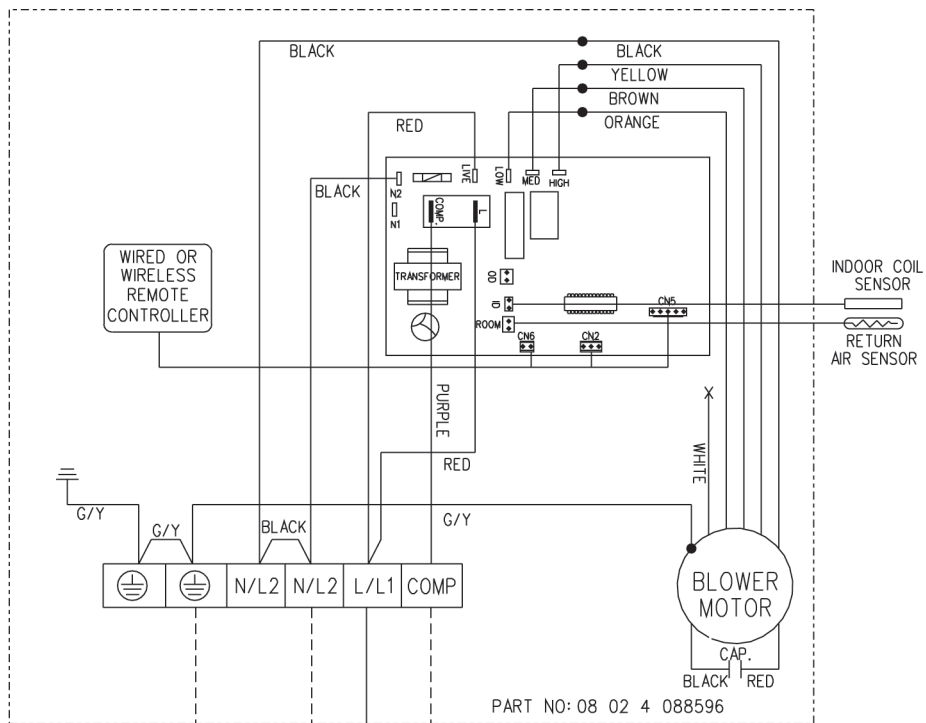

1 PHASE
 220~415VAC 50Hz OR
 208~230VAC 60Hz

E
 N
 L

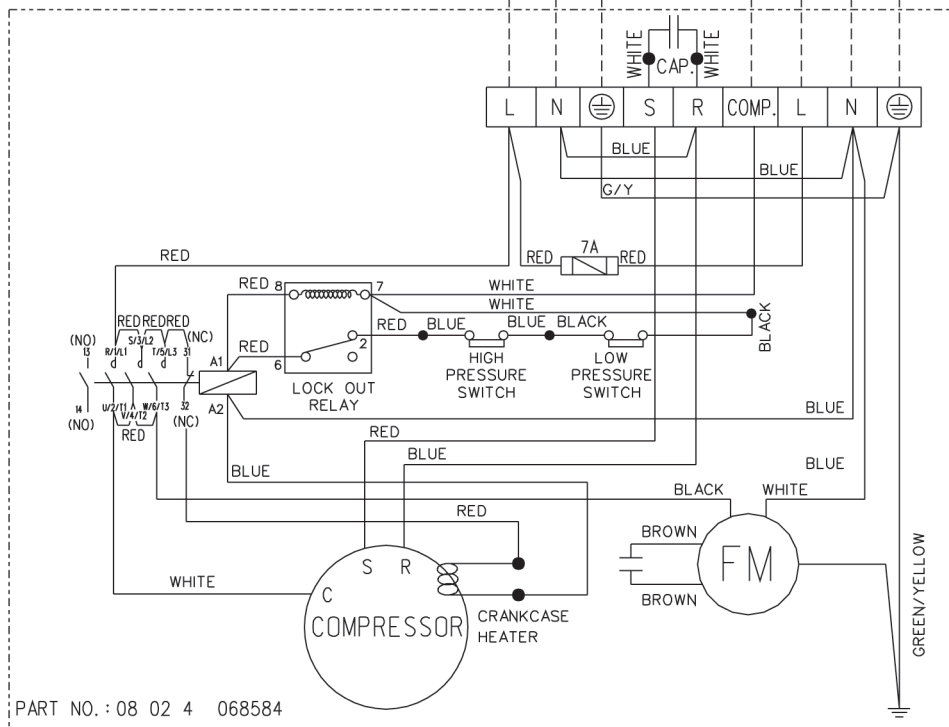

Outdoor Unit
Model : MLC / M5LC 030C (1 Phase)

Indoor Unit
Model : MCC 028 / 030C, M5CC 028C

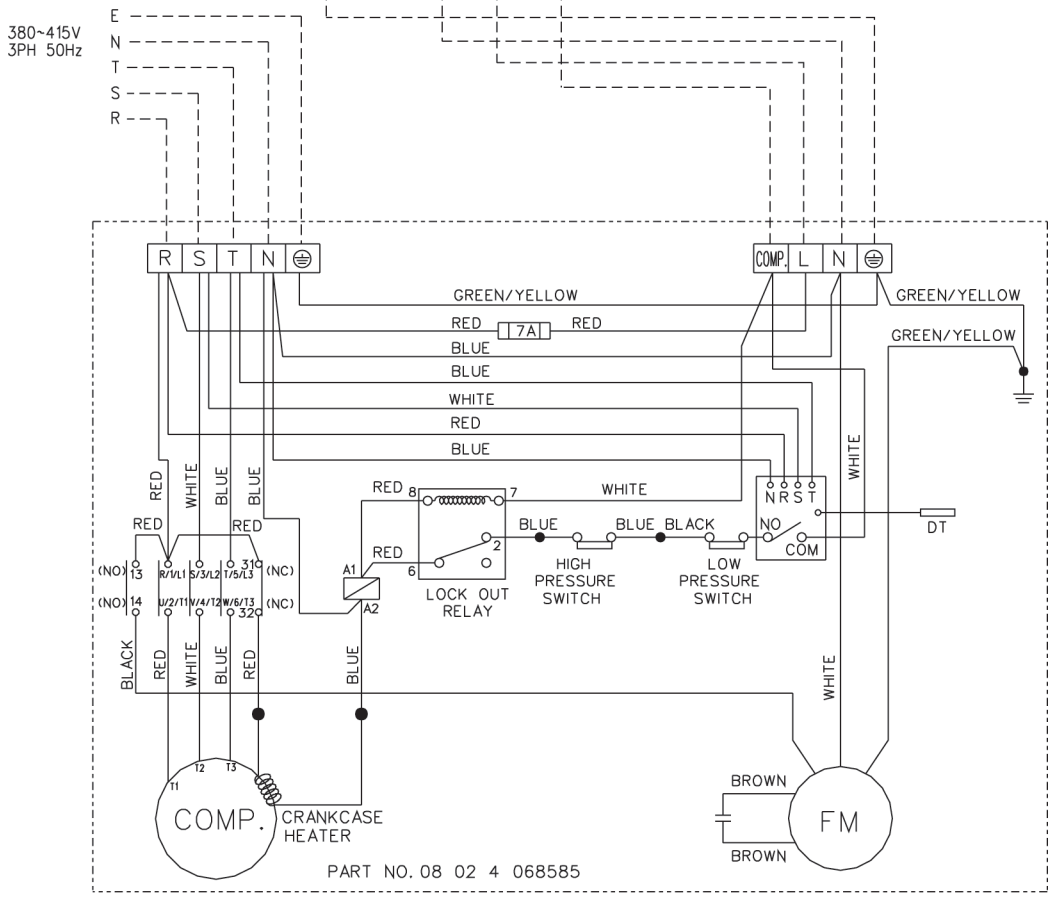
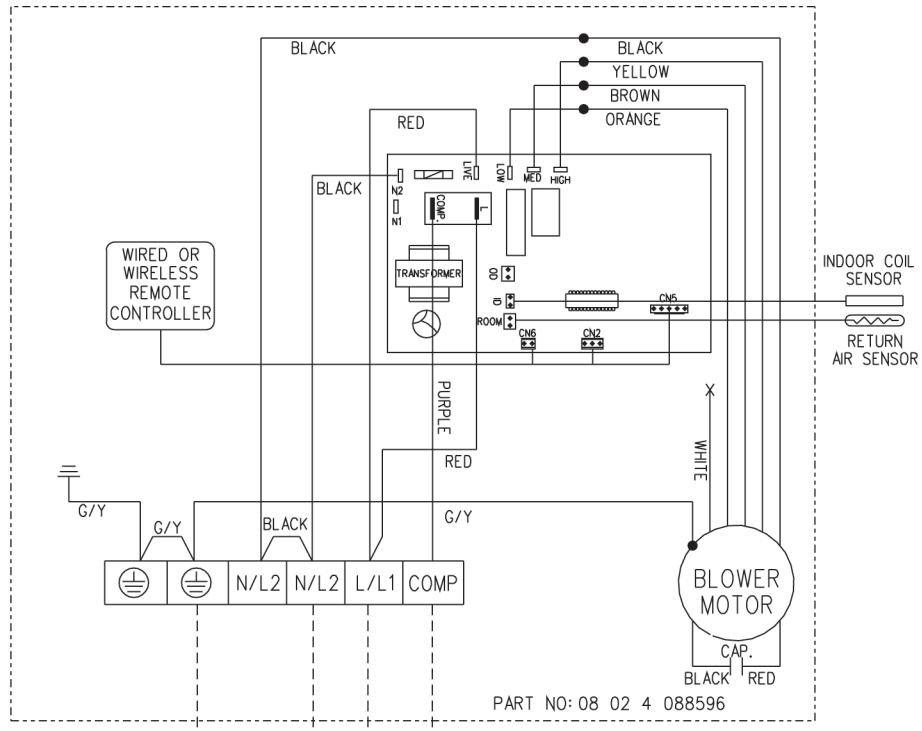

Outdoor Unit
Model : MLC 030C, M5LC 035C (3 Phase)

Indoor Unit
Model : MCC 038 / 040C

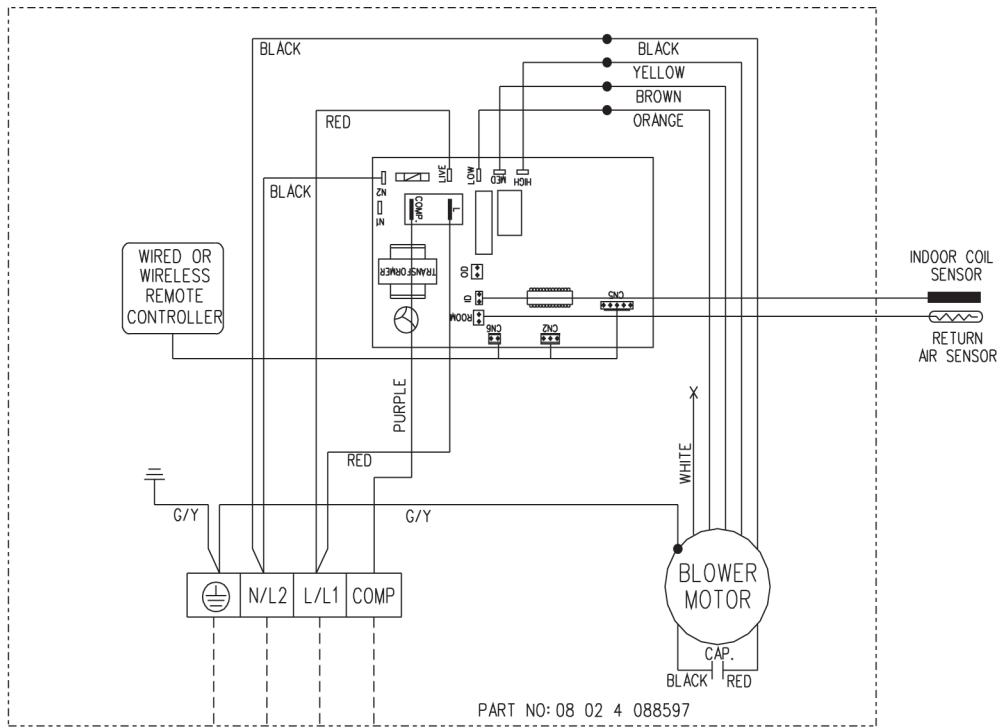

Outdoor Unit
Model : MLC 035 / 040C (1 Phase)

1 PHASE
 220~415VAC 50Hz OR
 208~230VAC 60Hz

E
 N
 L

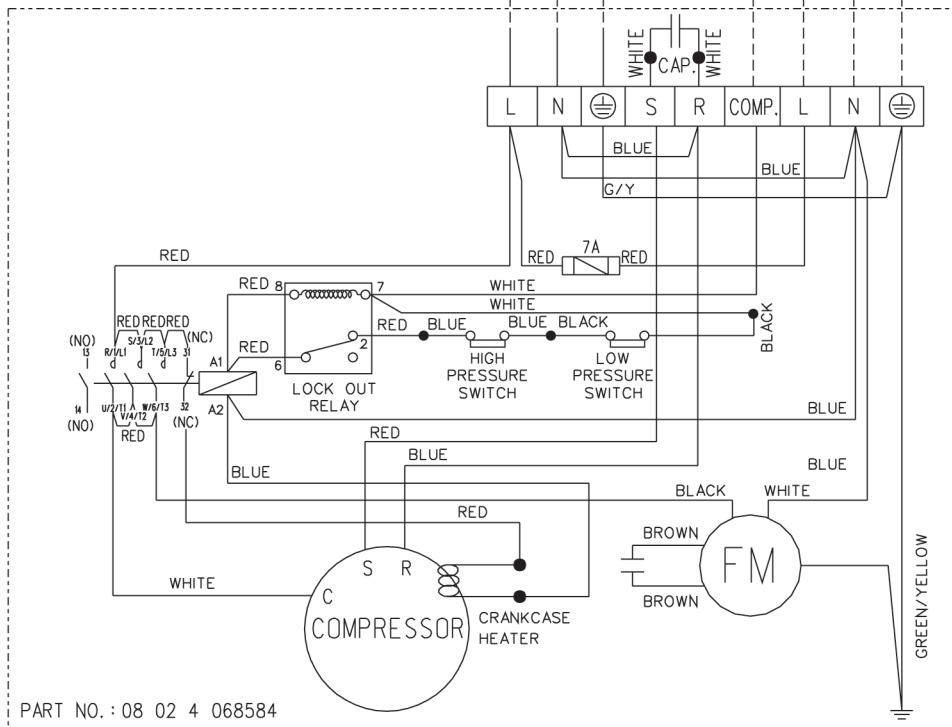

Indoor Unit
Model : MCC 038 / 040 / 050C, M5CC 038C

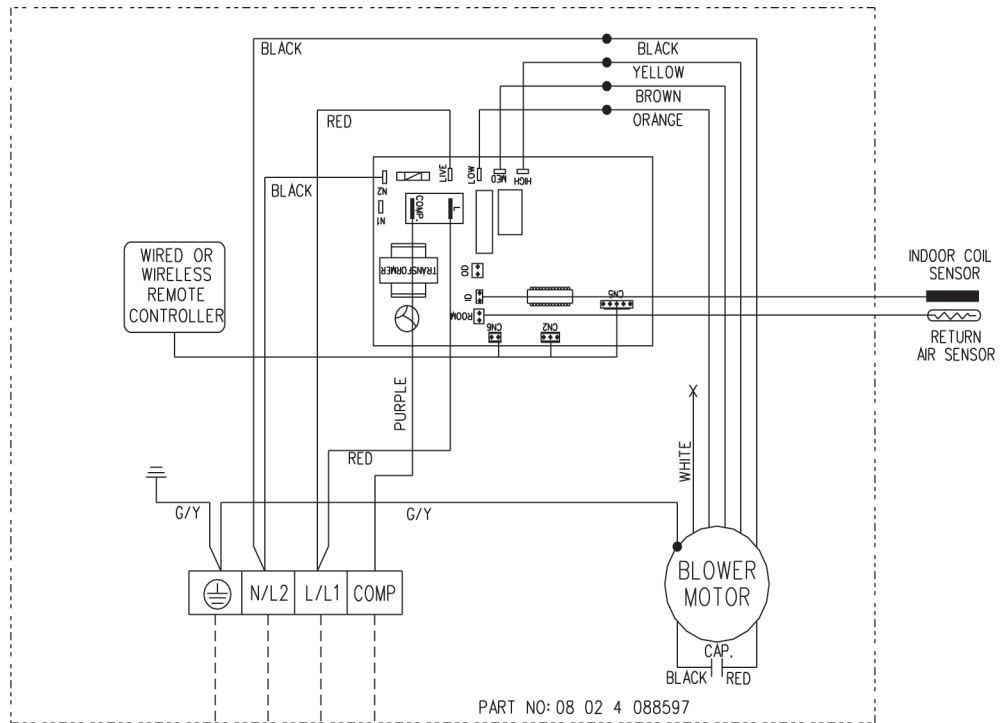

Outdoor Unit
Model : MLC 040 / 050C, M5LC 040C (3 Phase)

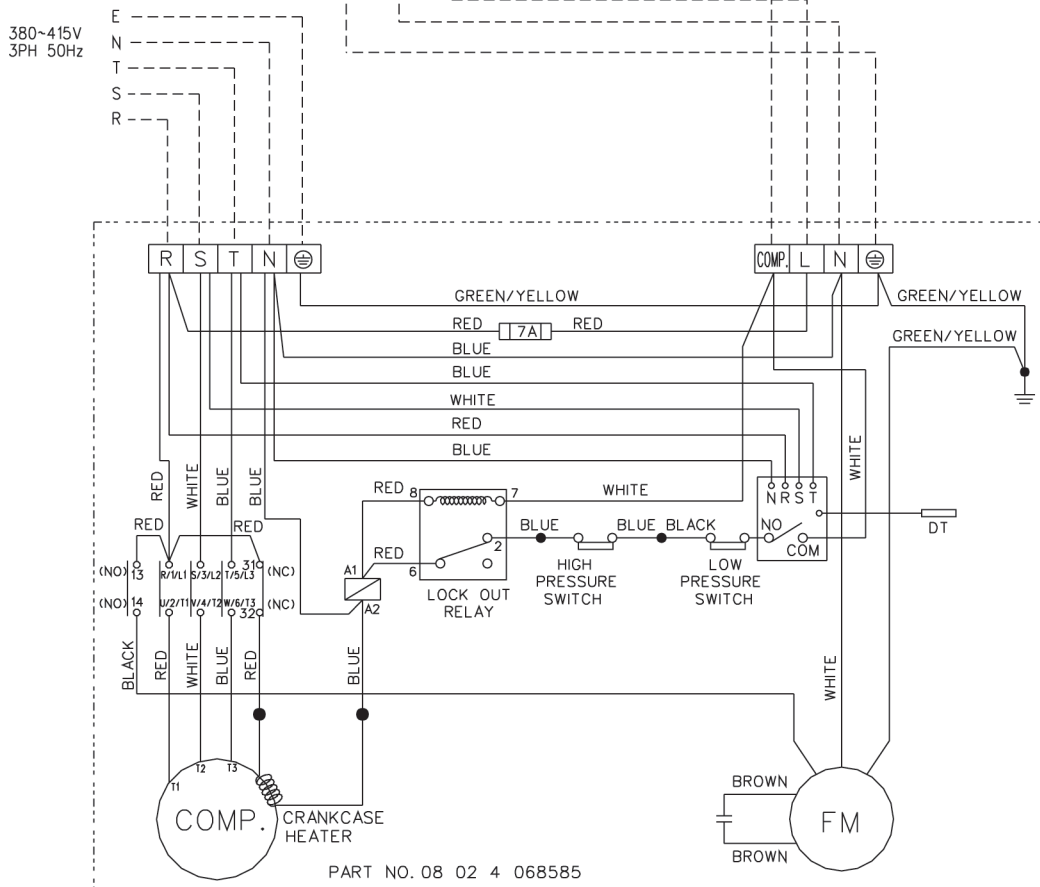

Indoor Unit
Model : M5CC 050 / 060C

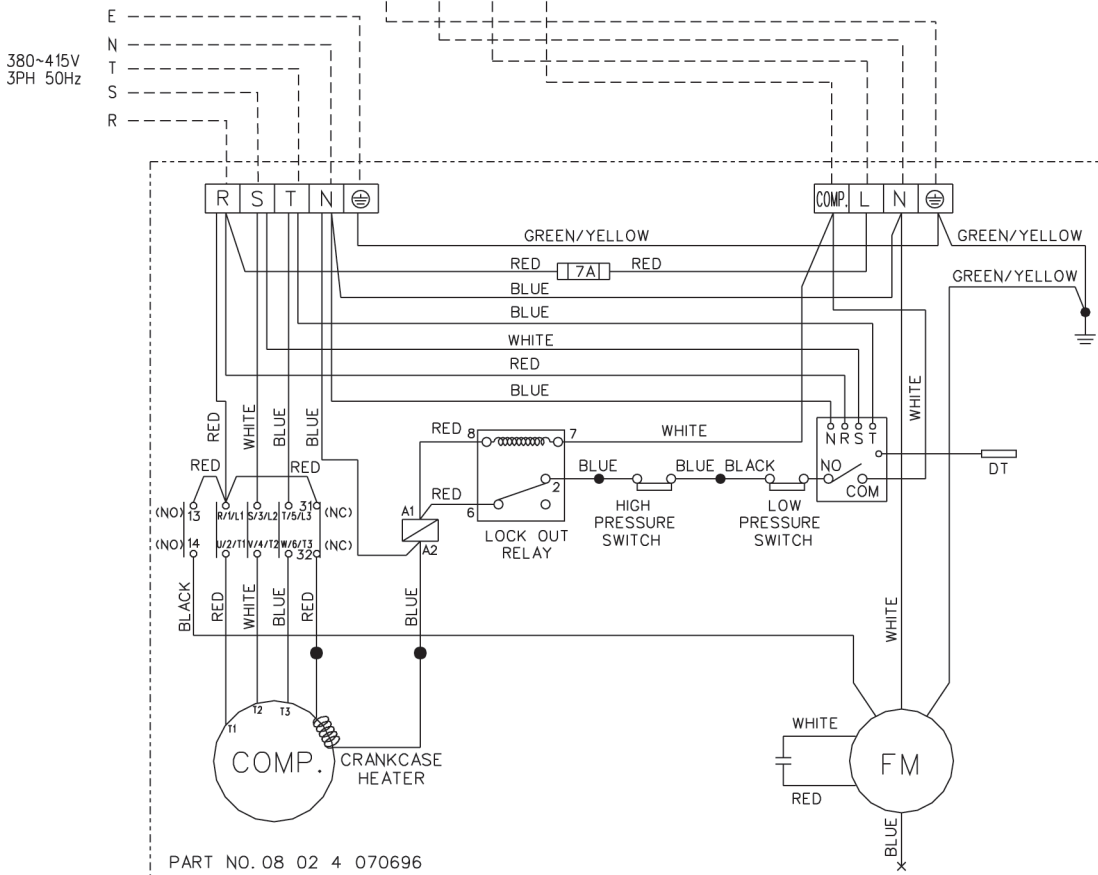
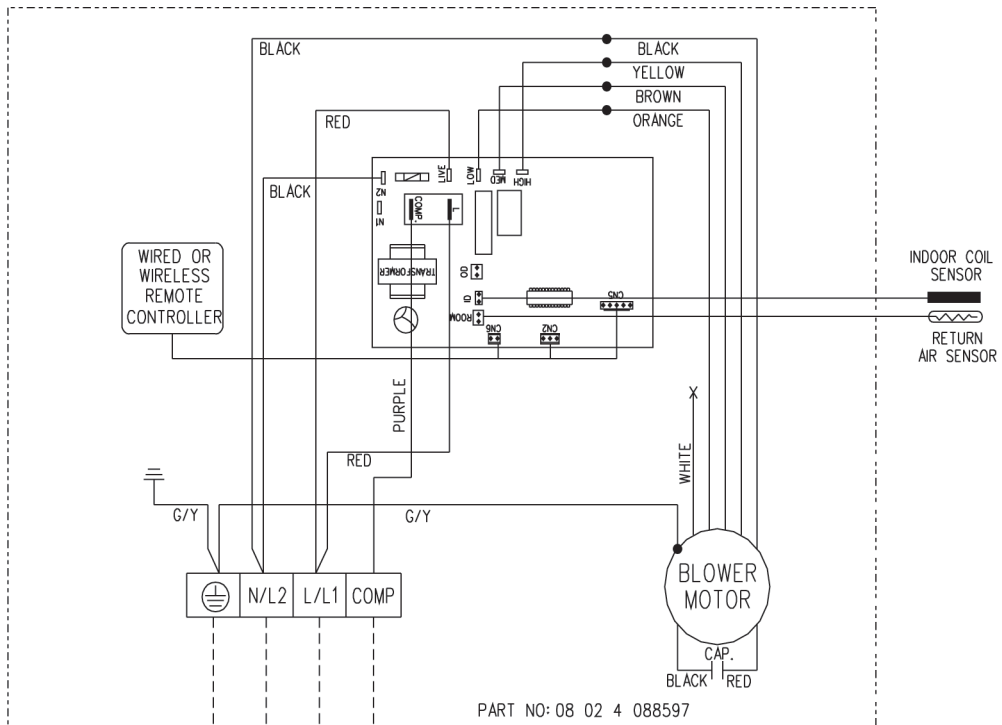

Outdoor Unit
Model : M5LC 050 / 061C

Indoor Unit
Model : MCC 060C

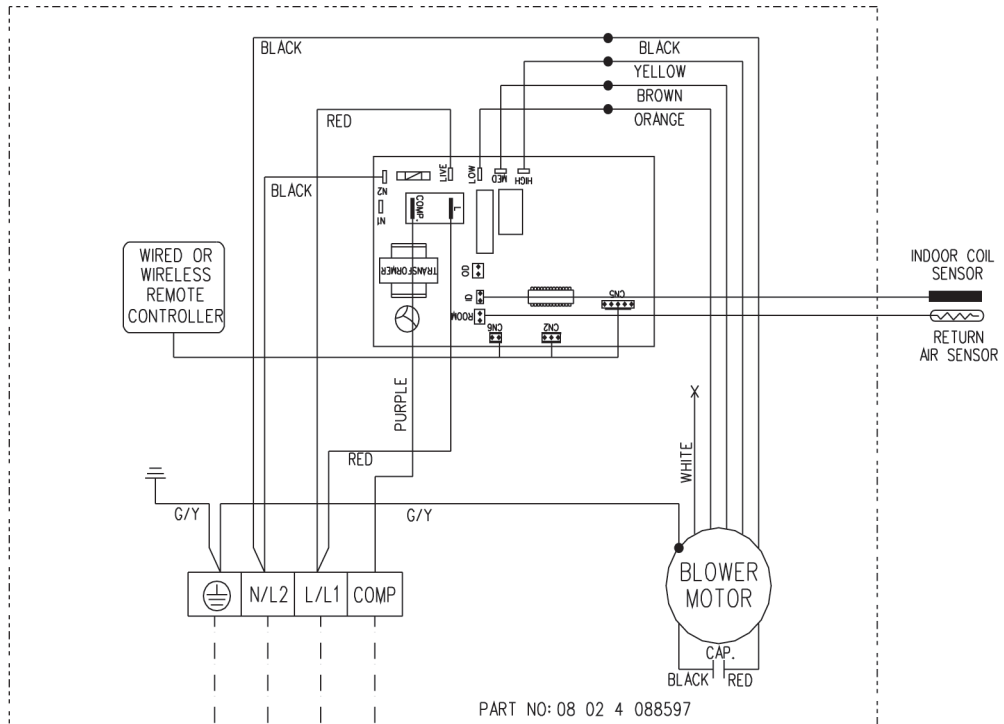

380~415V
 3PH 50Hz

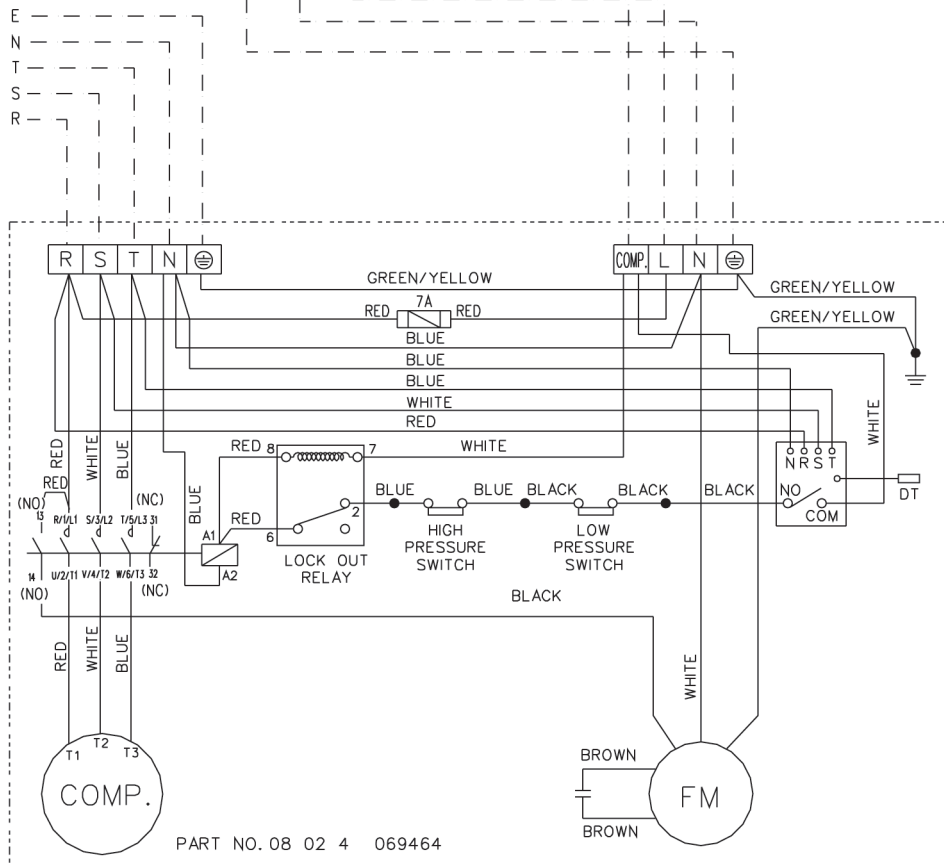

Outdoor Unit
Model : MLC 061C

Heatpump

Indoor Unit

Model : MCC 010CR, M5CC 010 / 015CR

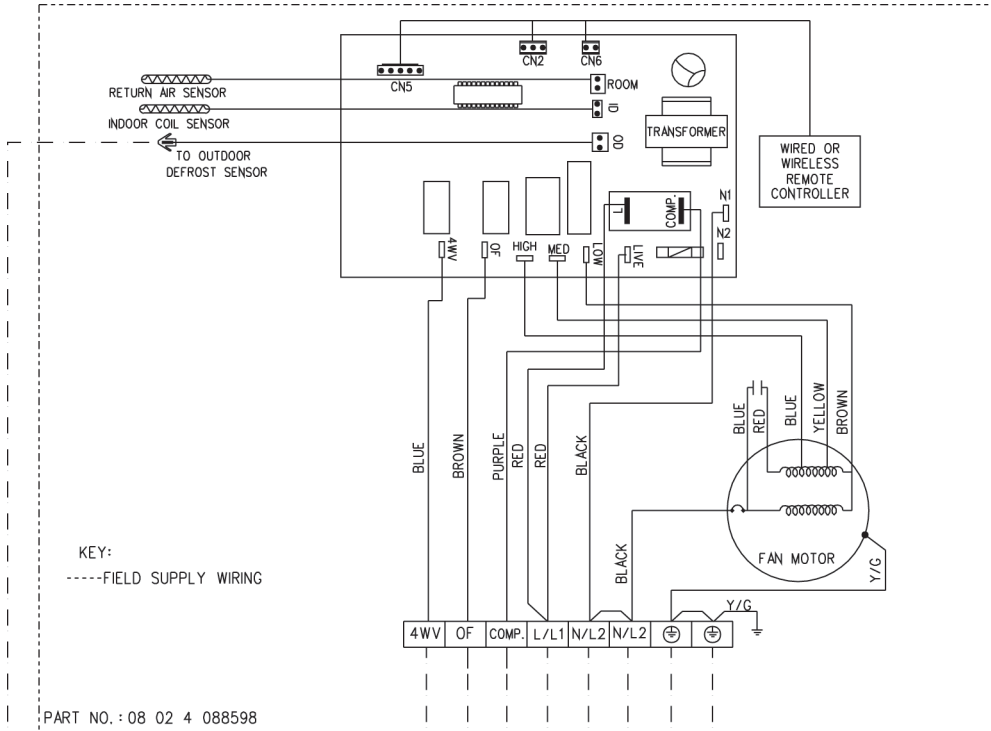

- E 1 PHASE
- N 220-240VAC 50Hz OR
- L 208-230VAC 60Hz

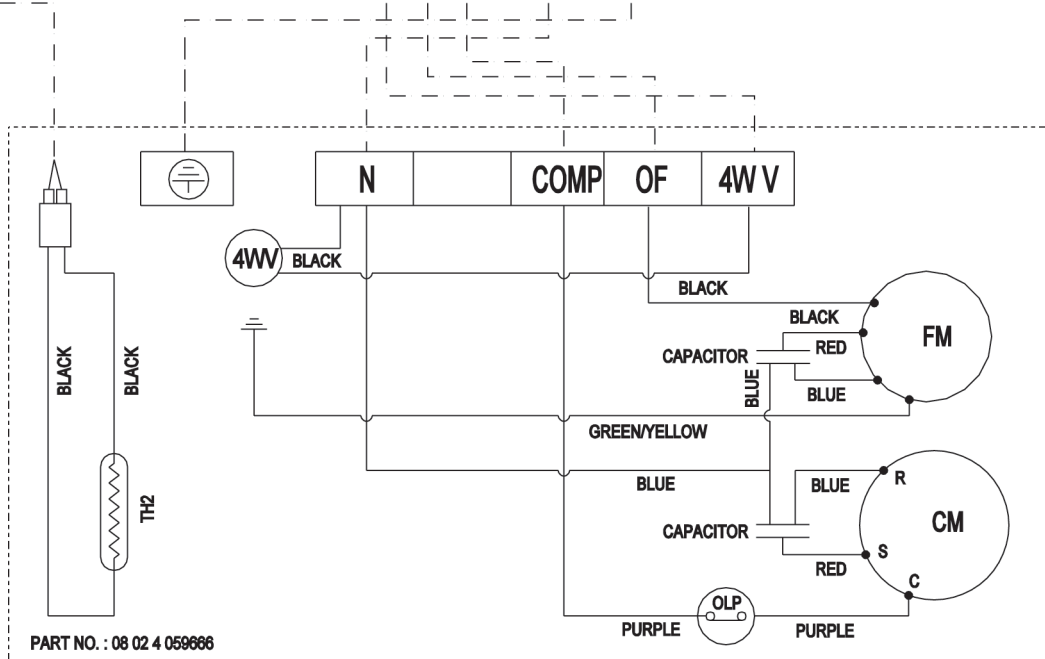

Outdoor Unit

Model : MLC 010CR, M5LC 010 / 015CR

**Indoor Unit
Model : MCC 015CR**

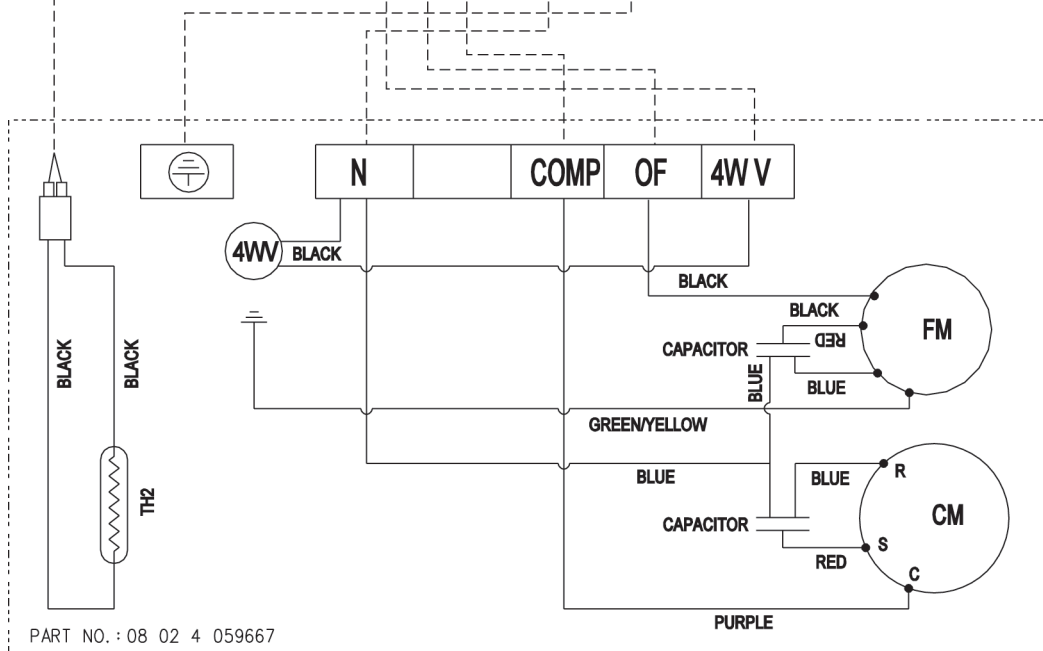
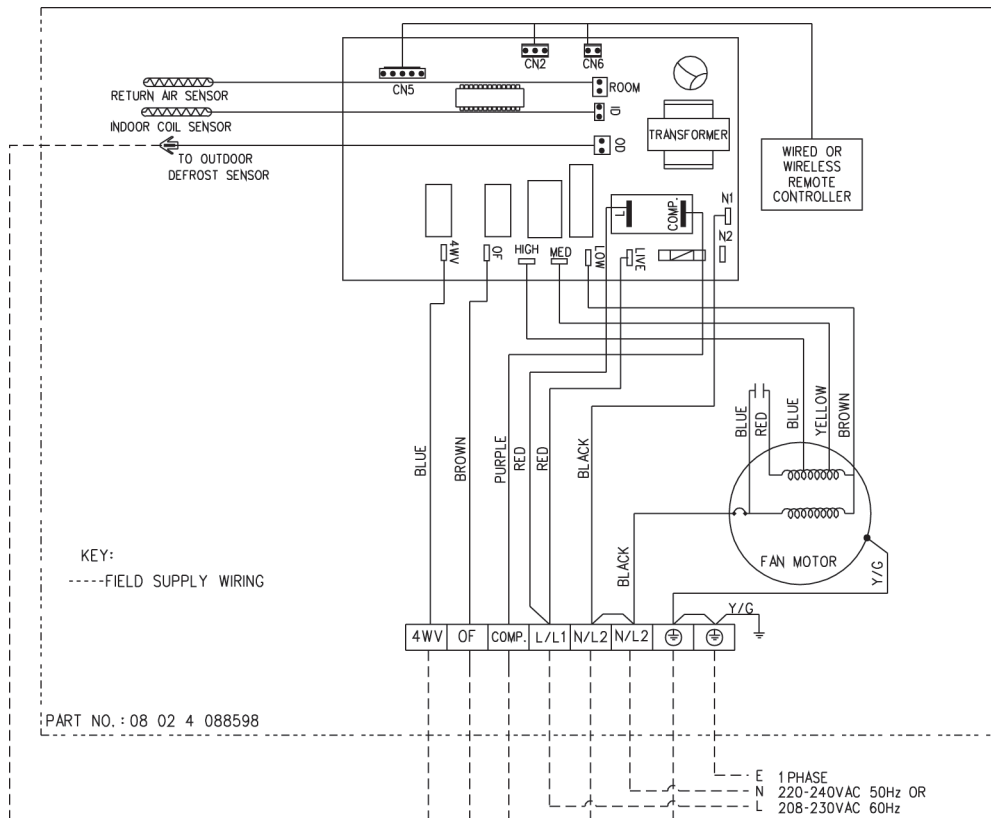

**Outdoor Unit
Model : MLC 015CR**

Indoor Unit
Model : MCC / M5CC 020 / 025CR

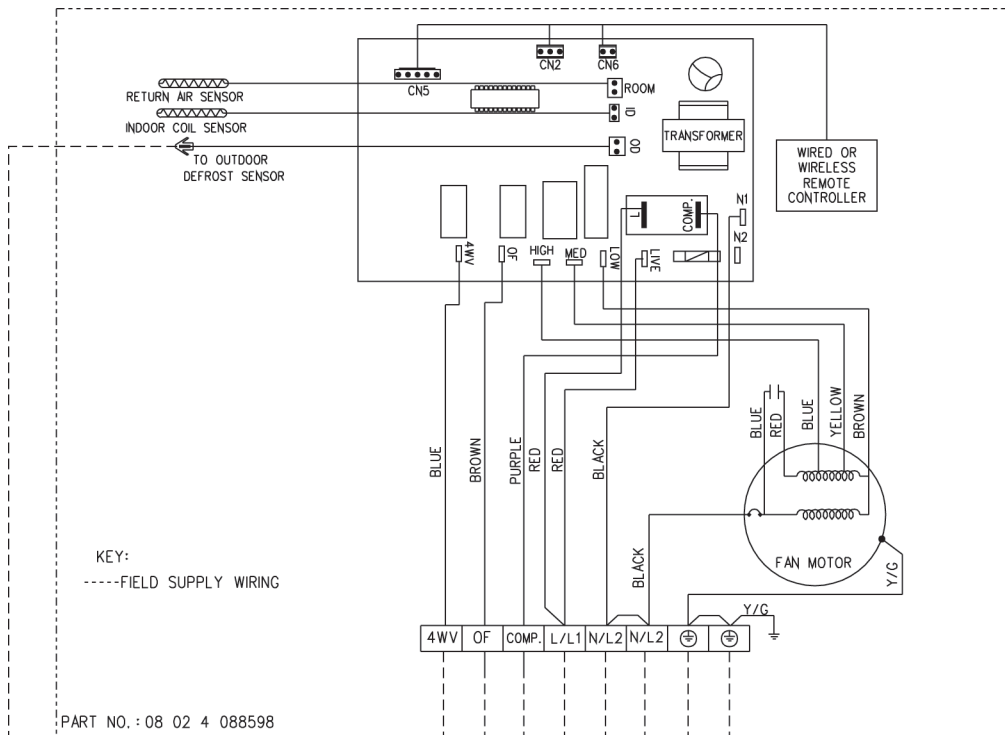

E 1PHASE
 N 220-240VAC 50Hz OR
 L 208-230VAC 60Hz

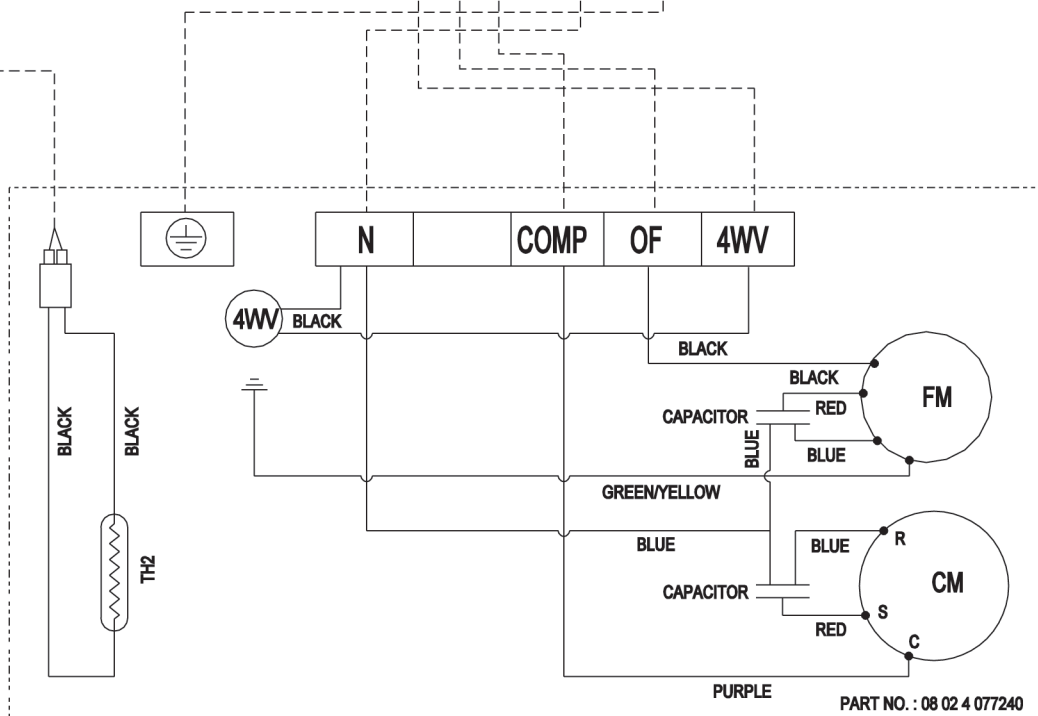

Outdoor Unit
Model : MLC / M5LC 020 / 025CR, MLC 018CR

Indoor Unit
Model : MCC / M5CC 028CR, MCC 030CR

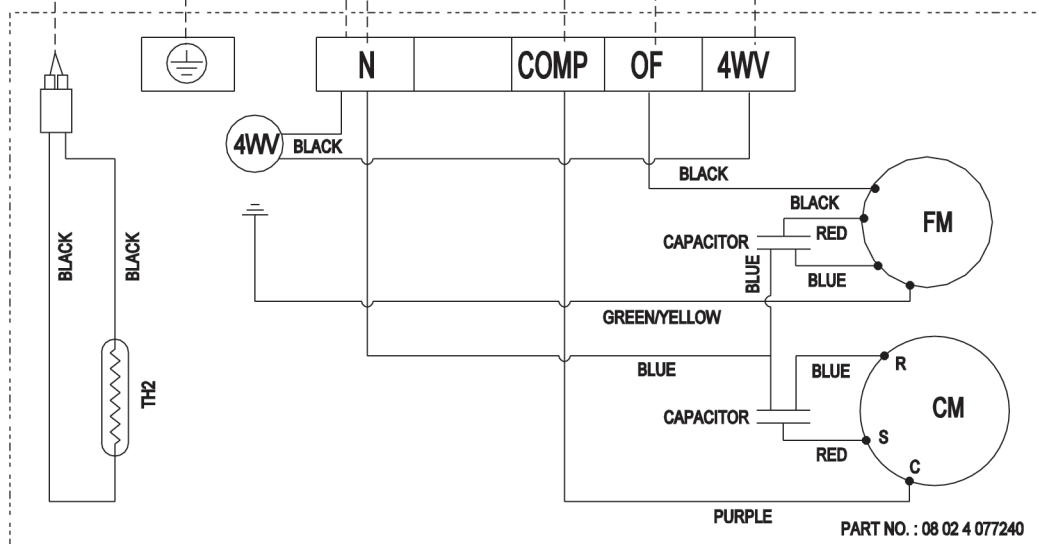
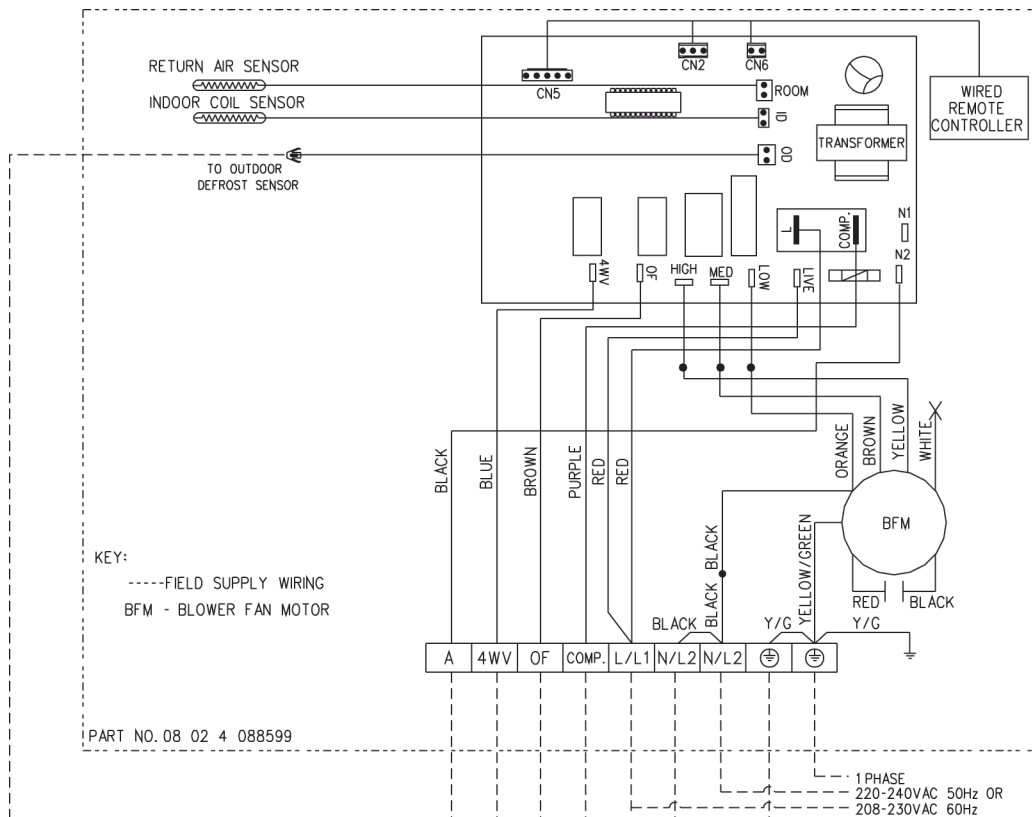

Outdoor Unit
Model : MLC / M5LC 028CR

Indoor Unit
Model : MCC 028 / 030CR

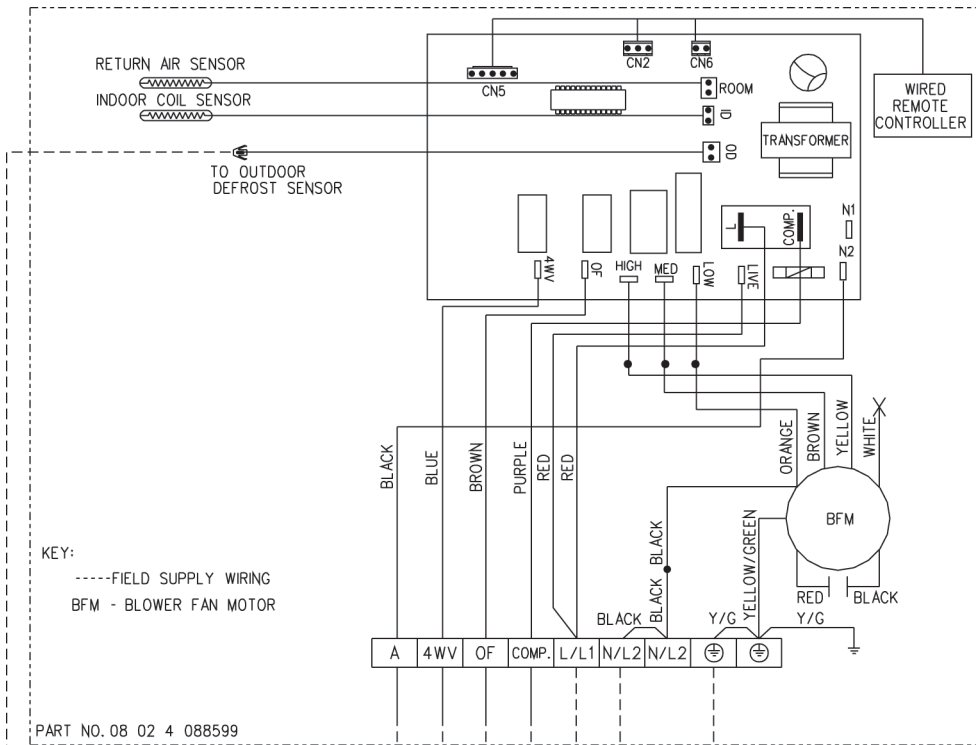

1 PHASE
 220-415VAC 50Hz OR
 208-230VAC 60Hz

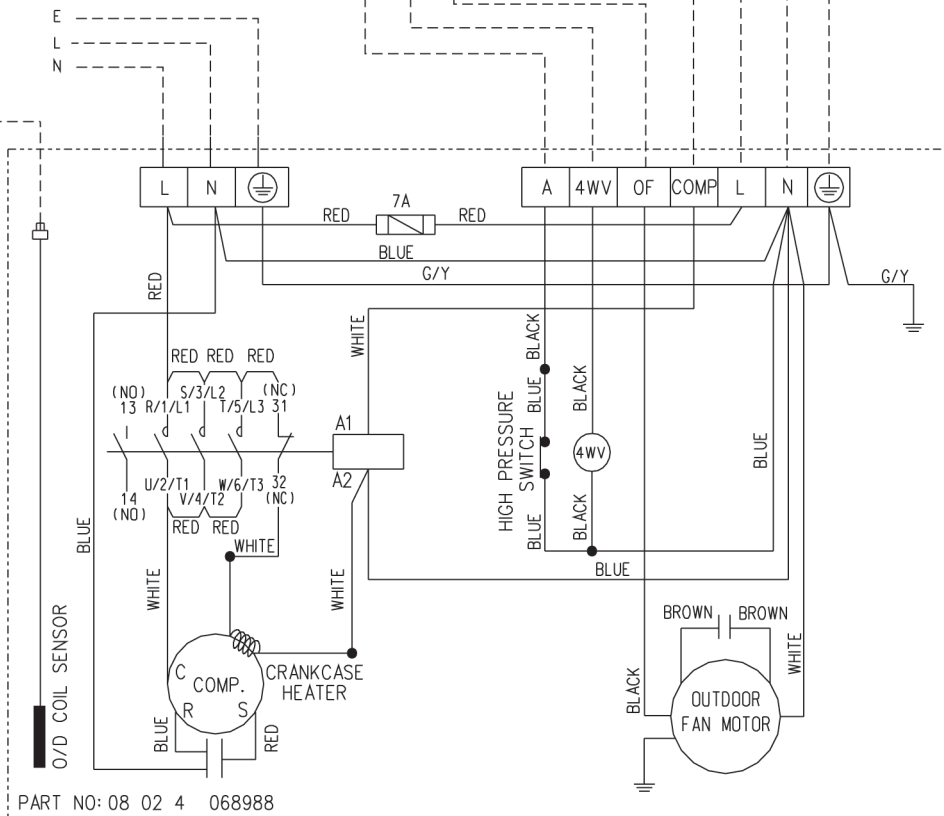

Outdoor Unit
Model : MLC 030CR (1 Phase)

Indoor Unit
Model : MCC 028 / 030CR

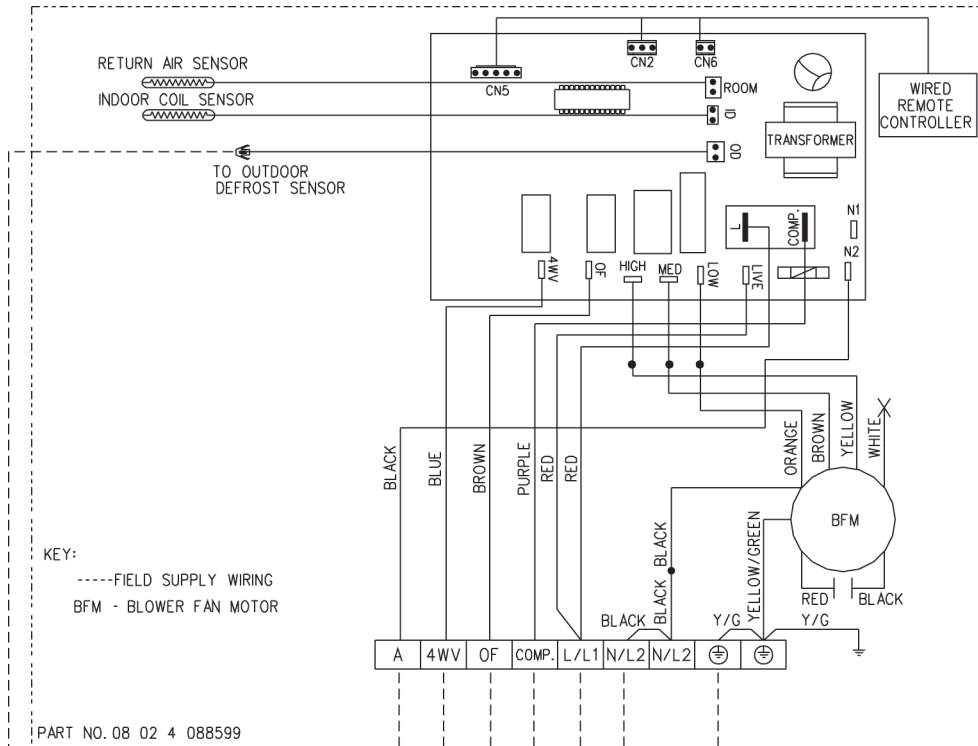

Outdoor Unit
Model : MLC 030CR (3 Phase)

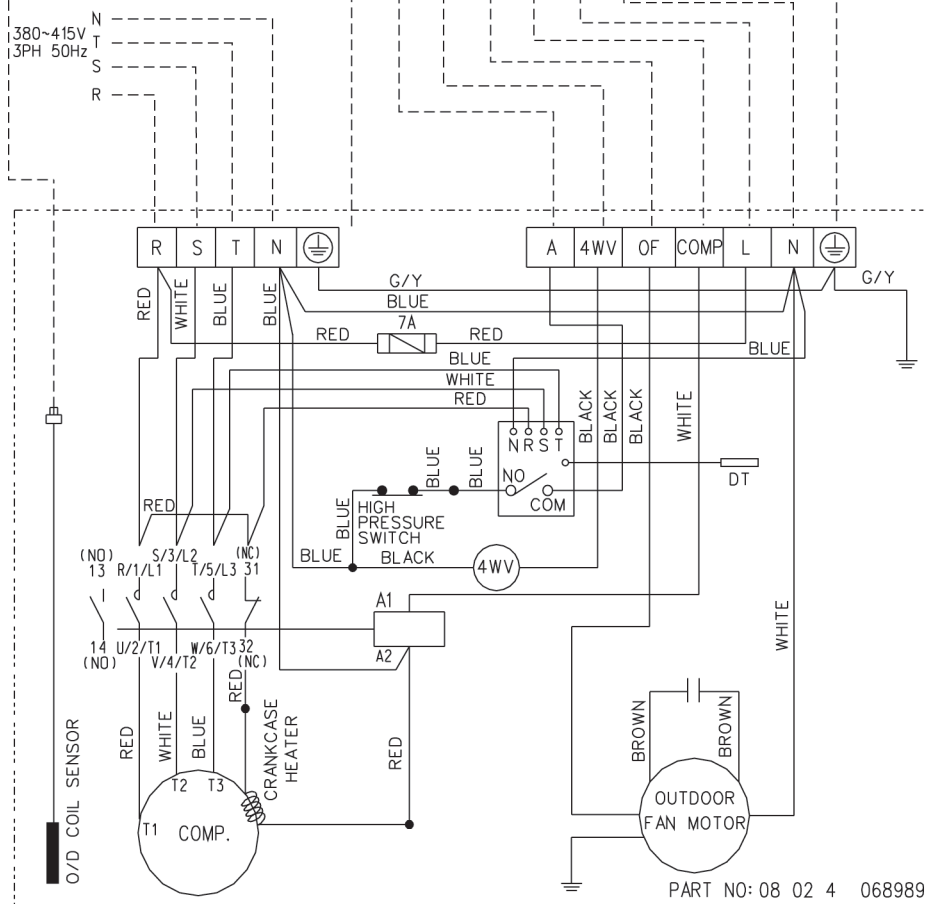

Indoor Unit

Model : M5CC 028CR

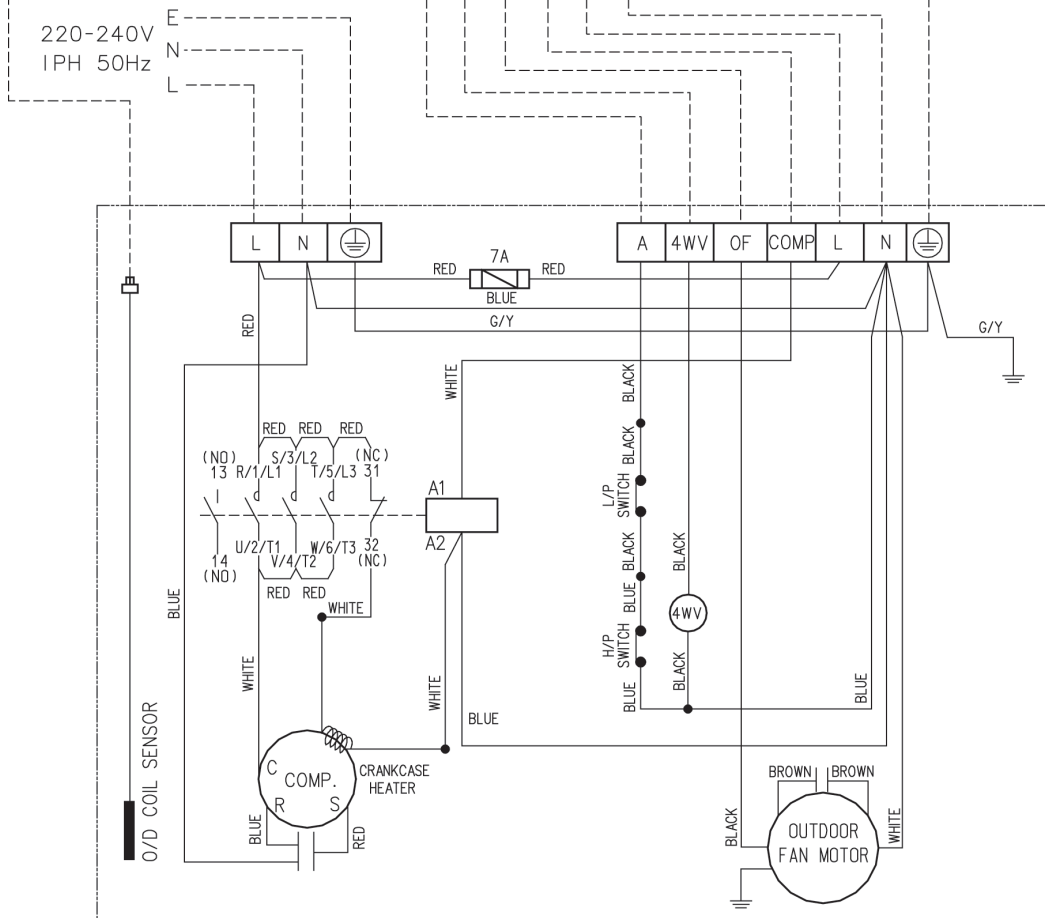
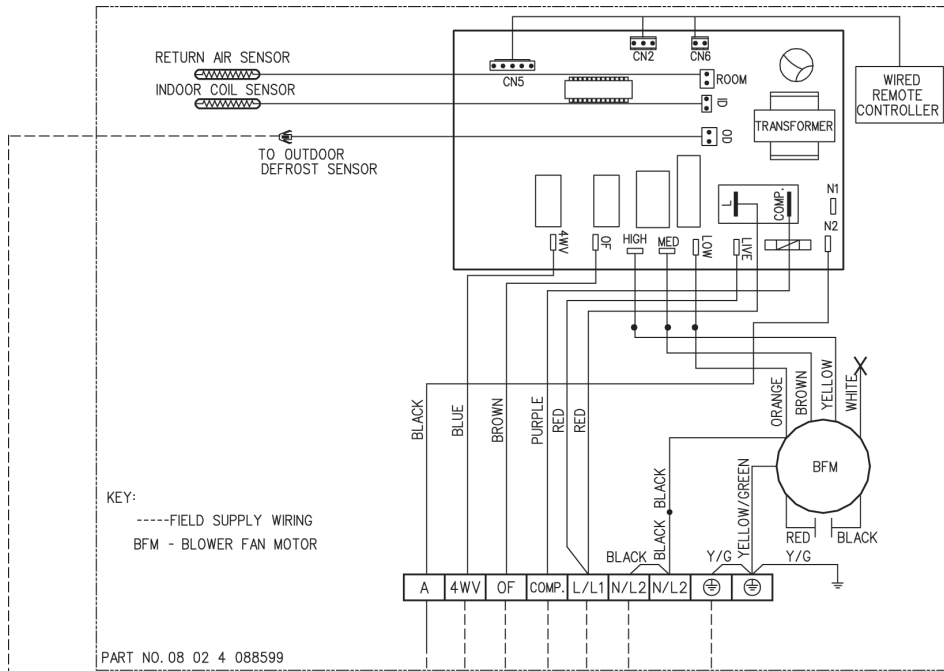

Outdoor Unit

Model : M5LC 035CR (1 Phase)

Indoor Unit Model M5CC 028CR

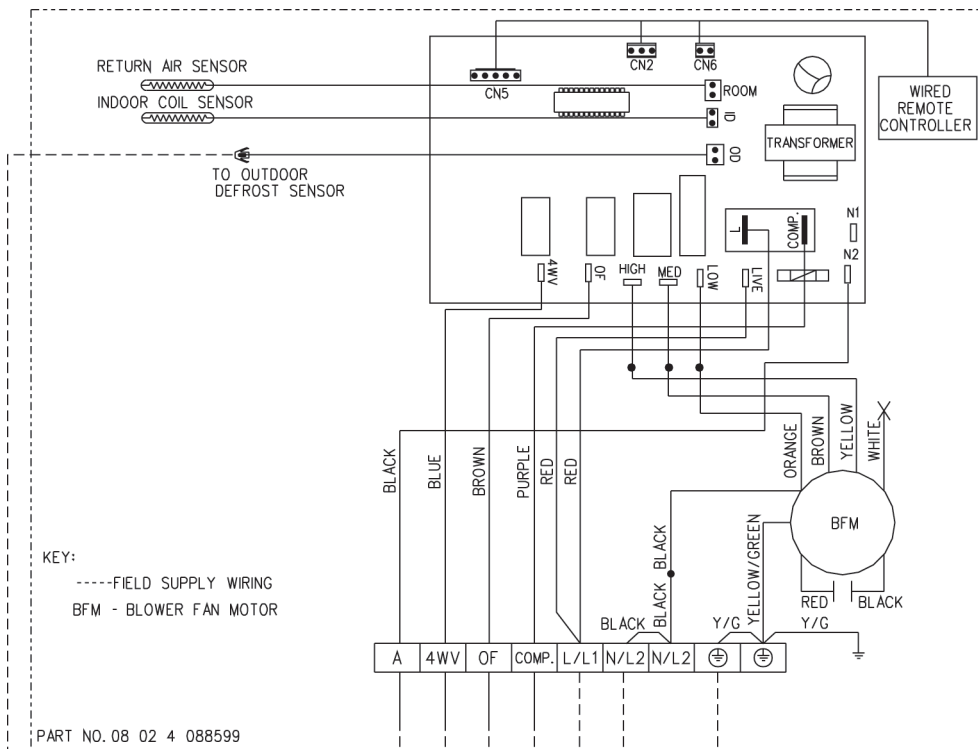

Outdoor Unit Model : M5LC 035CR (3 Phase)

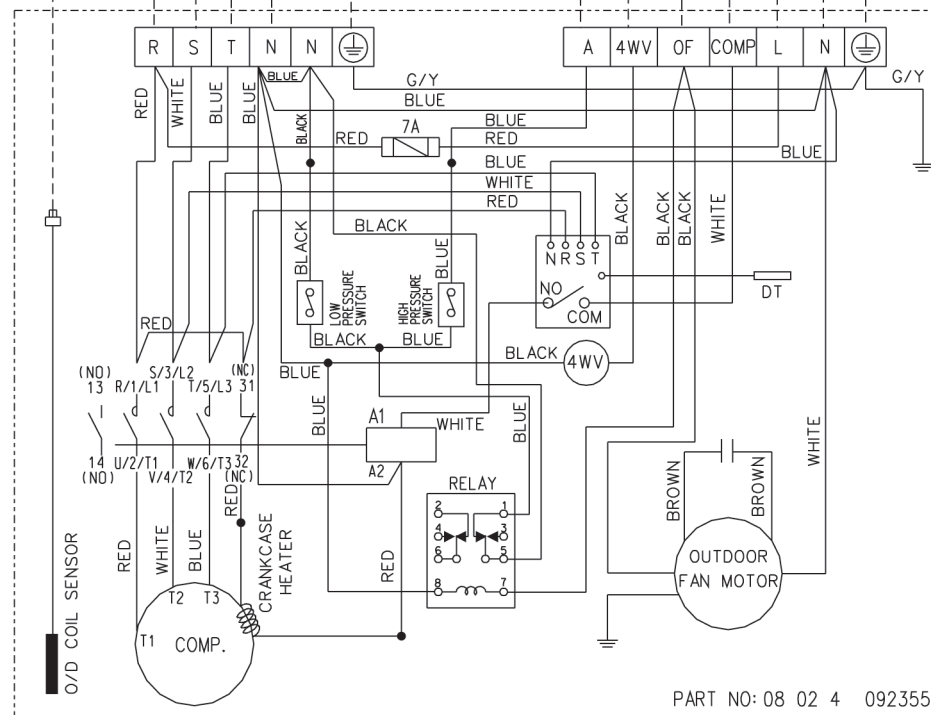

Indoor Unit
Model : MCC 038 / 040CR

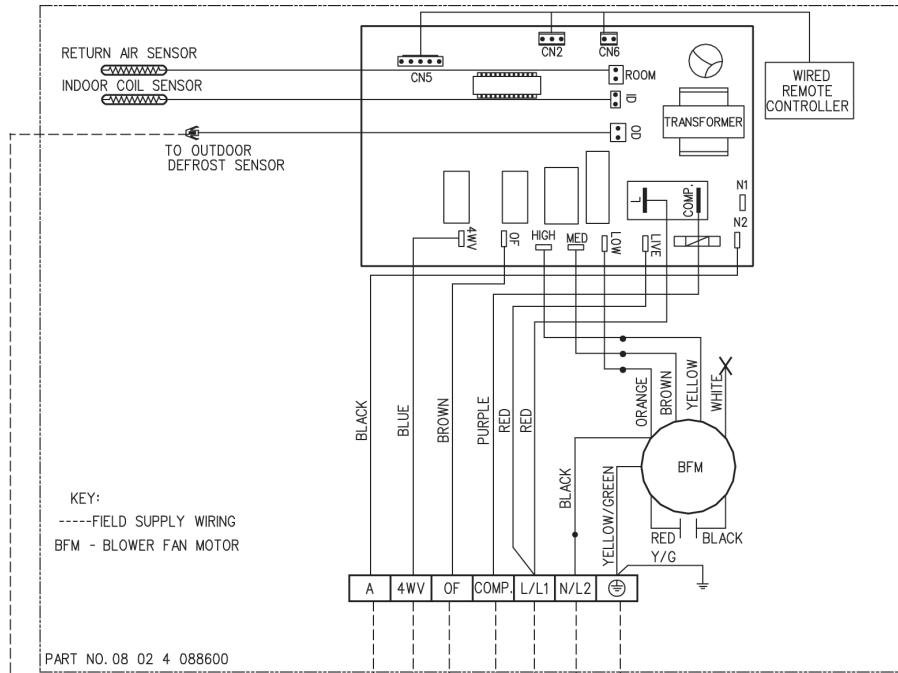

220-240V
 1PH
 50Hz
 E
 N
 L

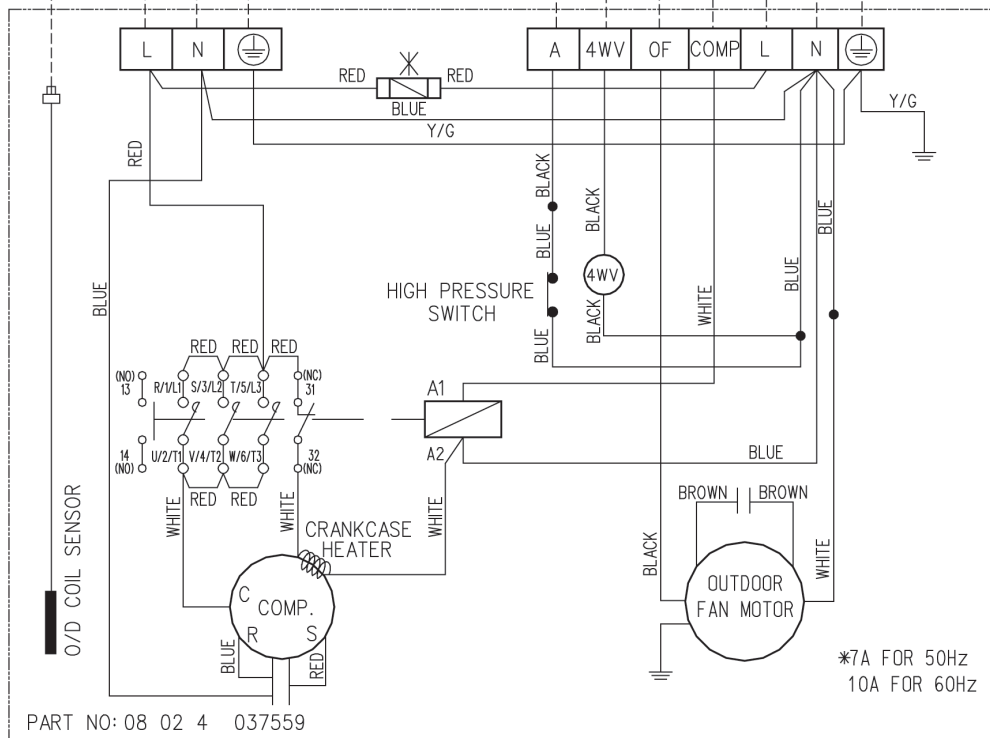

Outdoor Unit
Model : MLC 035 / 040CR (1 Phase)

Indoor Unit
Model : M5CC 038CR

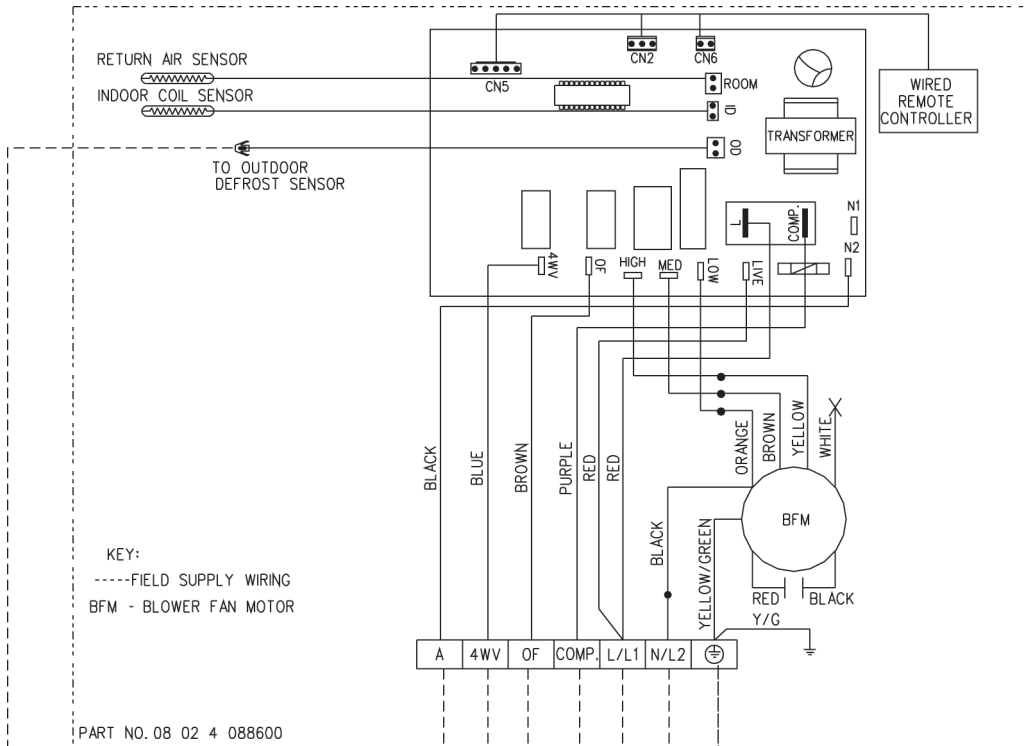

Outdoor Unit
Model : M5LC 040CR

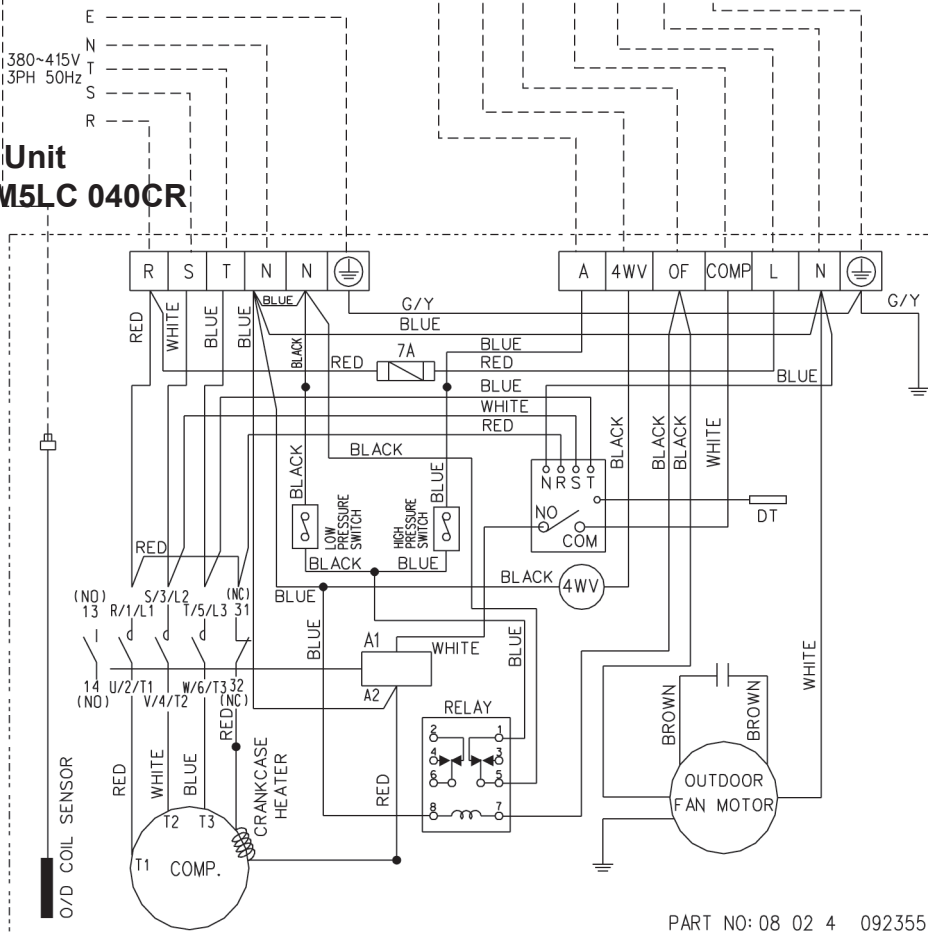

Indoor Unit
Model : MCC 038 / 040 / 050CR

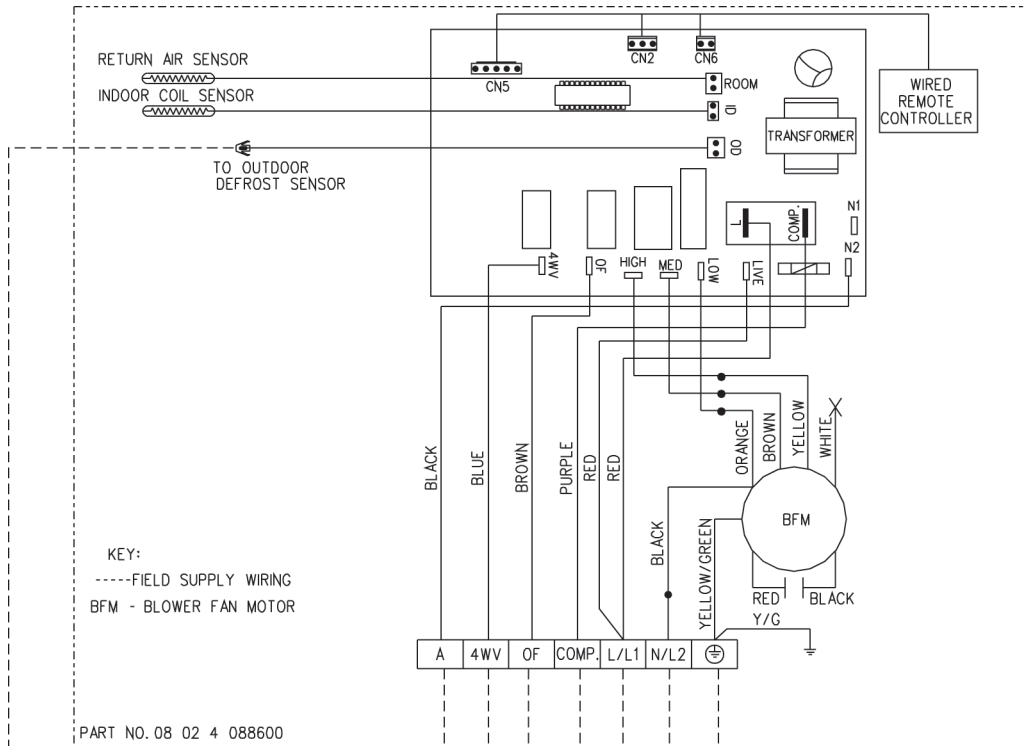

Outdoor Unit
Model : MLC 040 / 050CR (3 Phase)

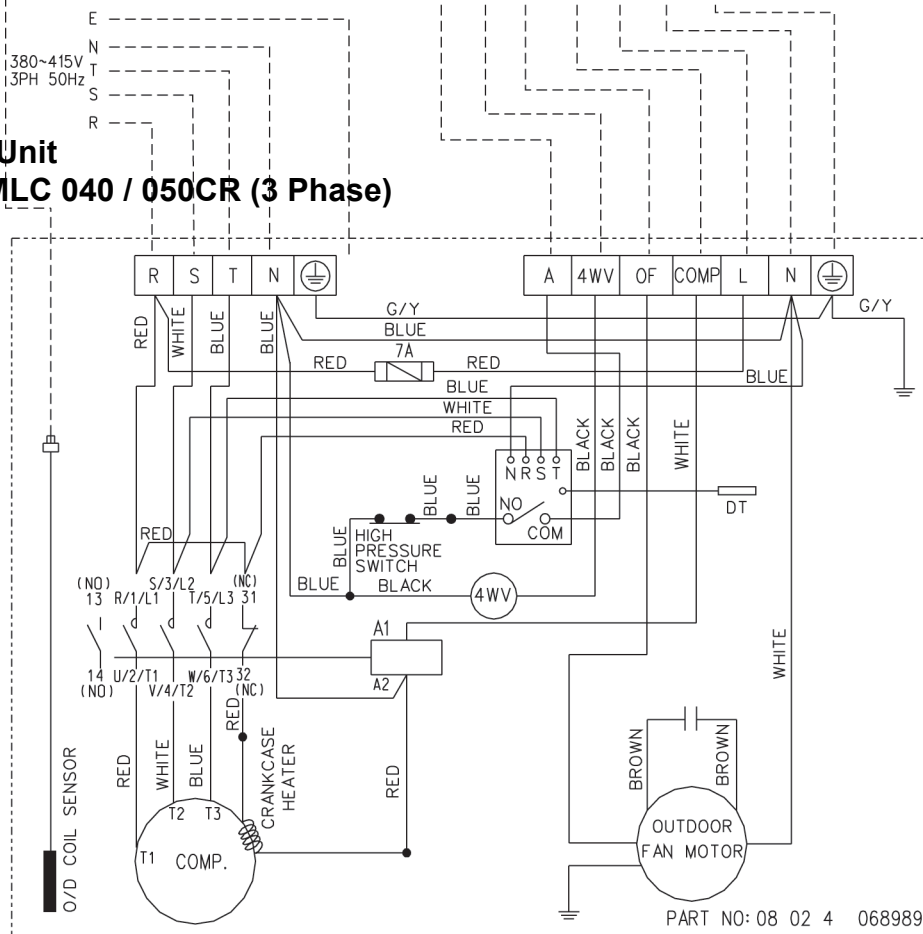

Indoor Unit
Model : M5CC 050 / 060CR

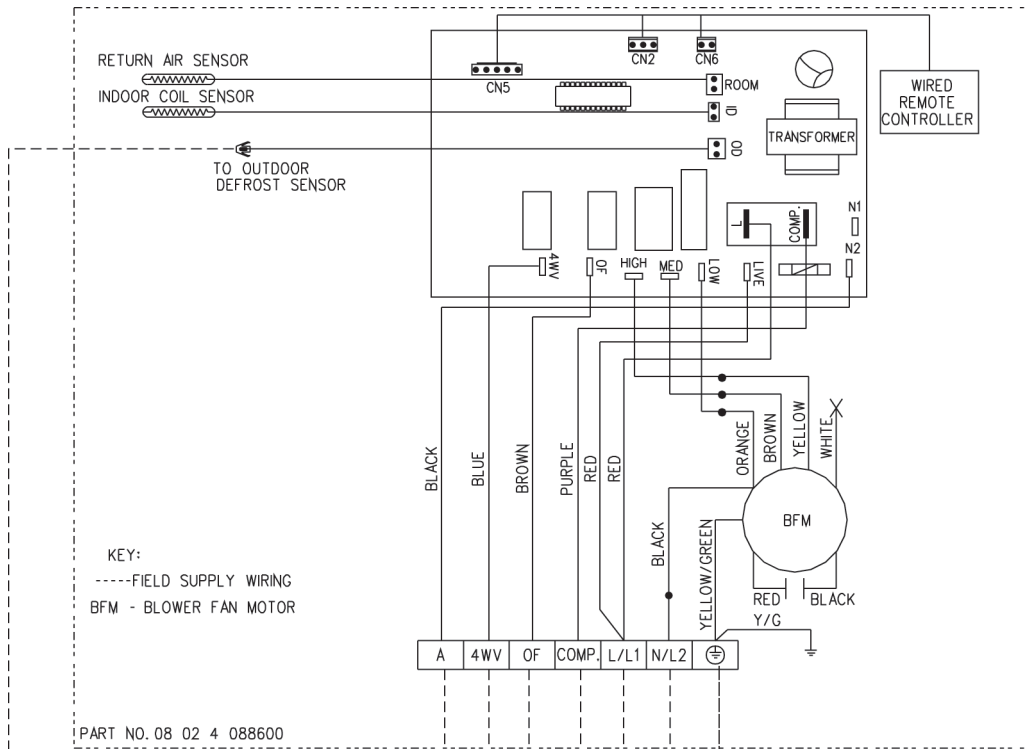

Outdoor Unit
Model : M5LC 050 / 061CR

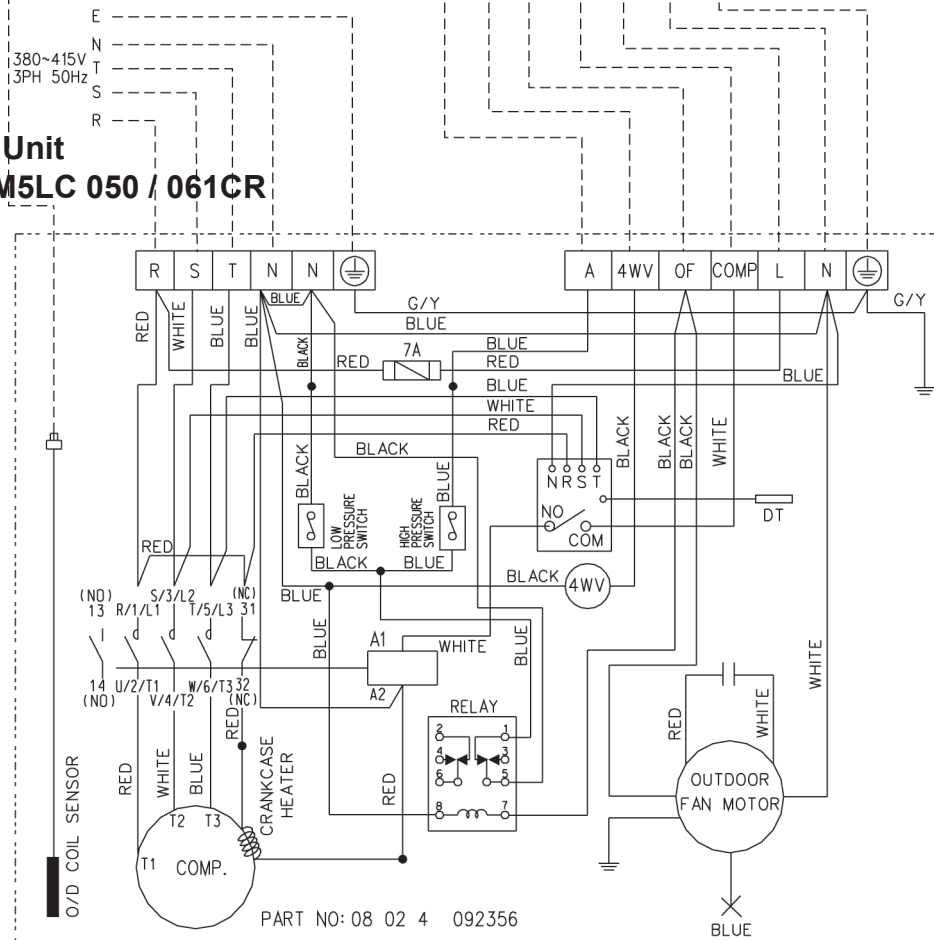

Indoor Unit
Model : MCC 060CR

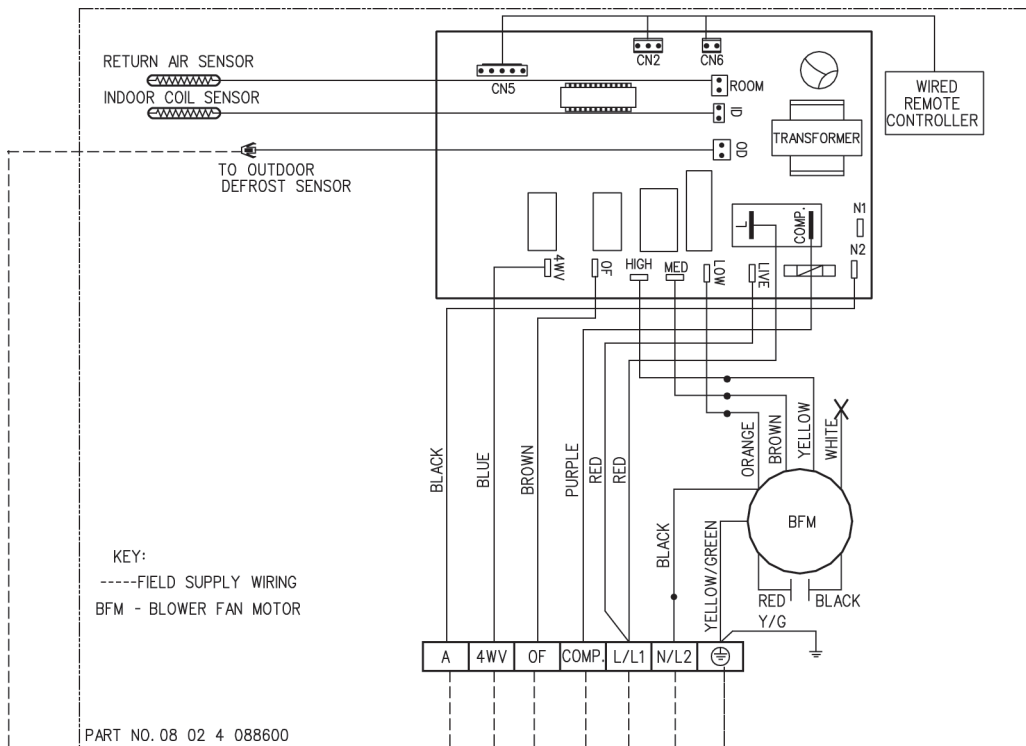

Outdoor Unit
Model : MLC 061CR

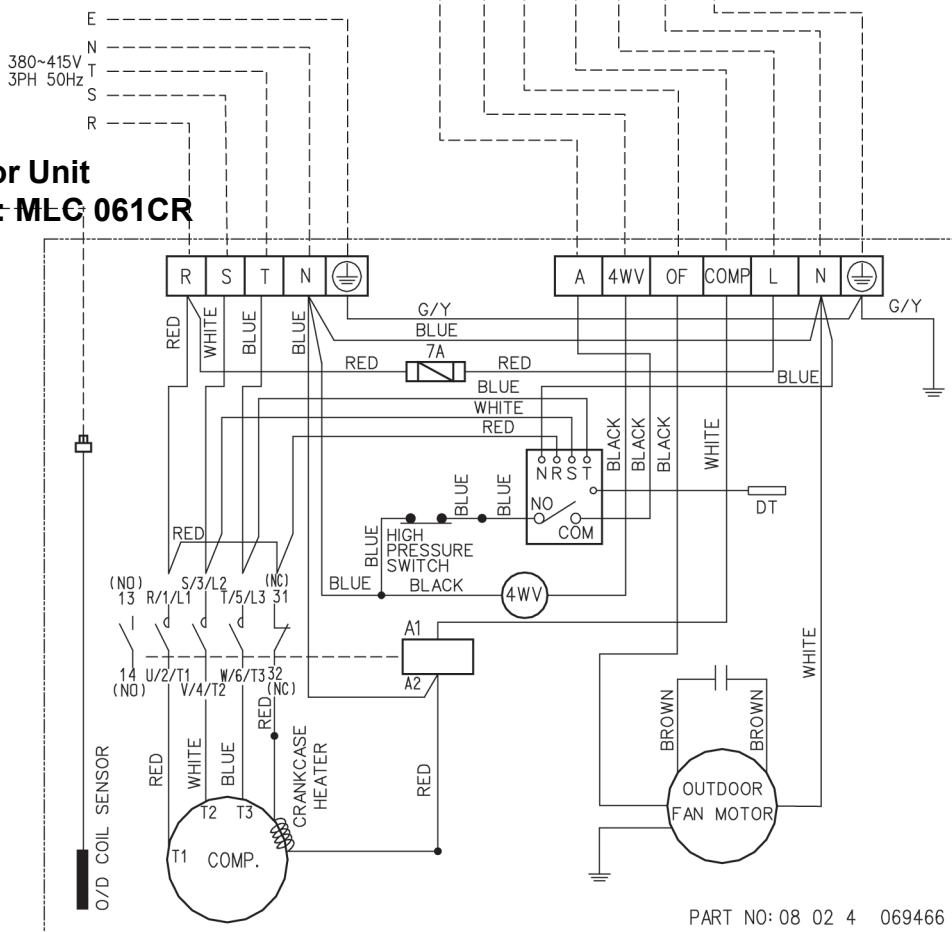

3 Phase for 2 & 2.5HP Outdoor Unit
Model : M5LC 020 / 025C (Cooling only)
3 Phase / 50 Hz / 380 ~ 415V

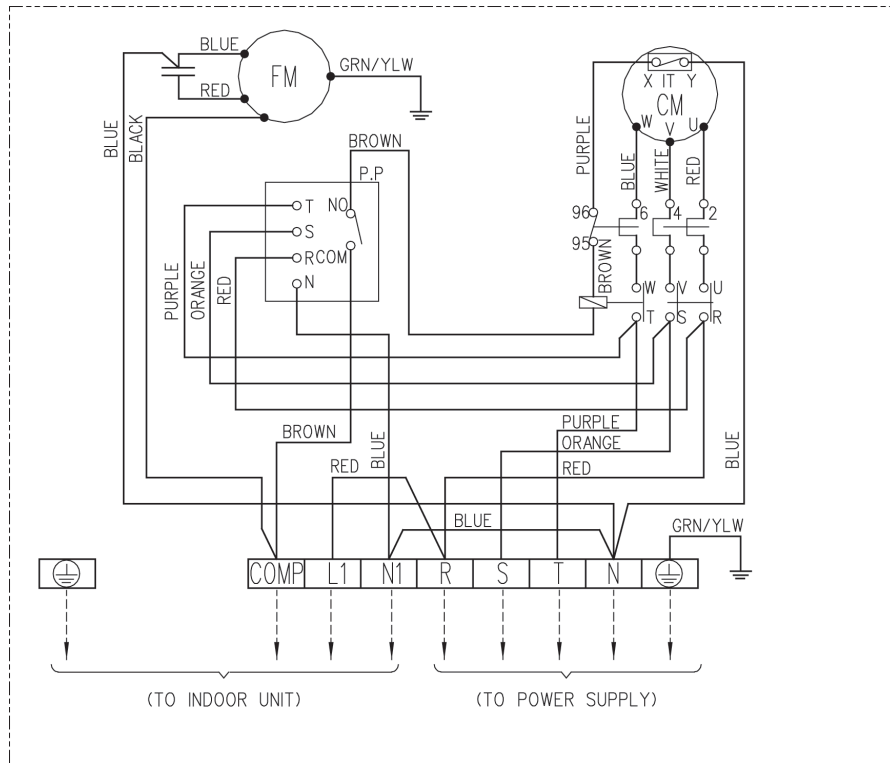

Model : M5LC 020 / 025CR (Heatpump)
3 Phase / 50 Hz / 380 ~ 415V

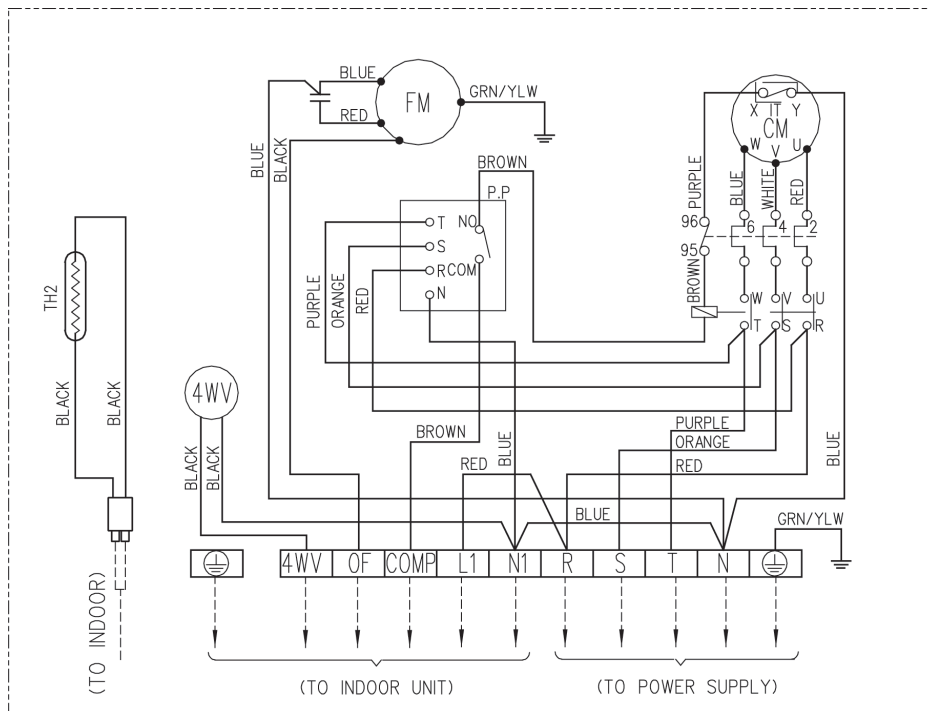

Outdoor Unit
Model : MLC 030C (Cooling only)
50Hz / 1 Phase / 220 ~ 240V

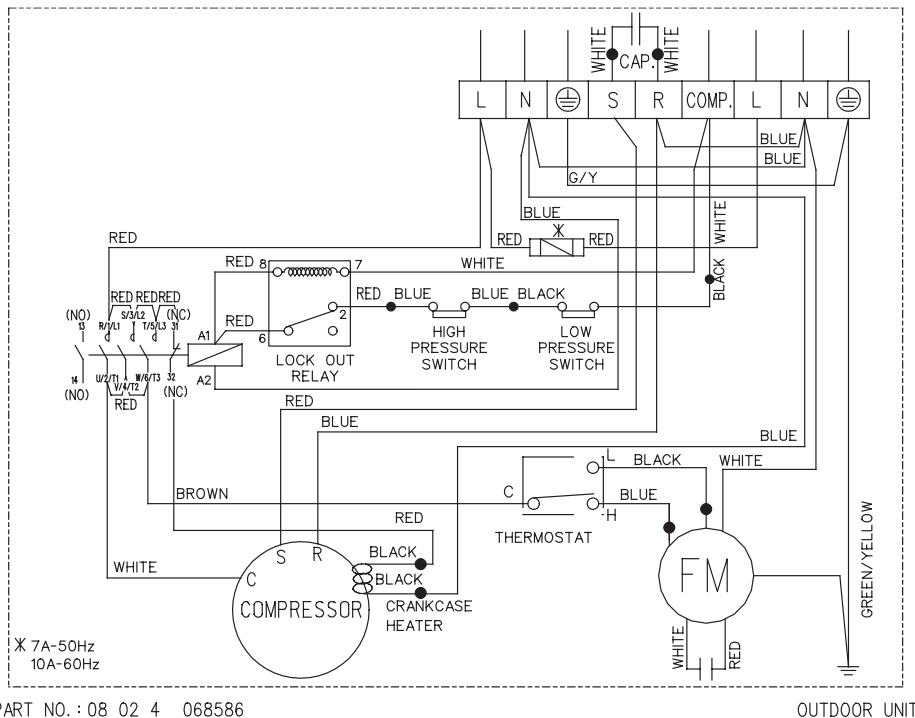

High Ambient Unit
Outdoor Unit
Model : MLC 040 / 050C (Cooling only)
50Hz / 3 Phase / 380 ~ 415V

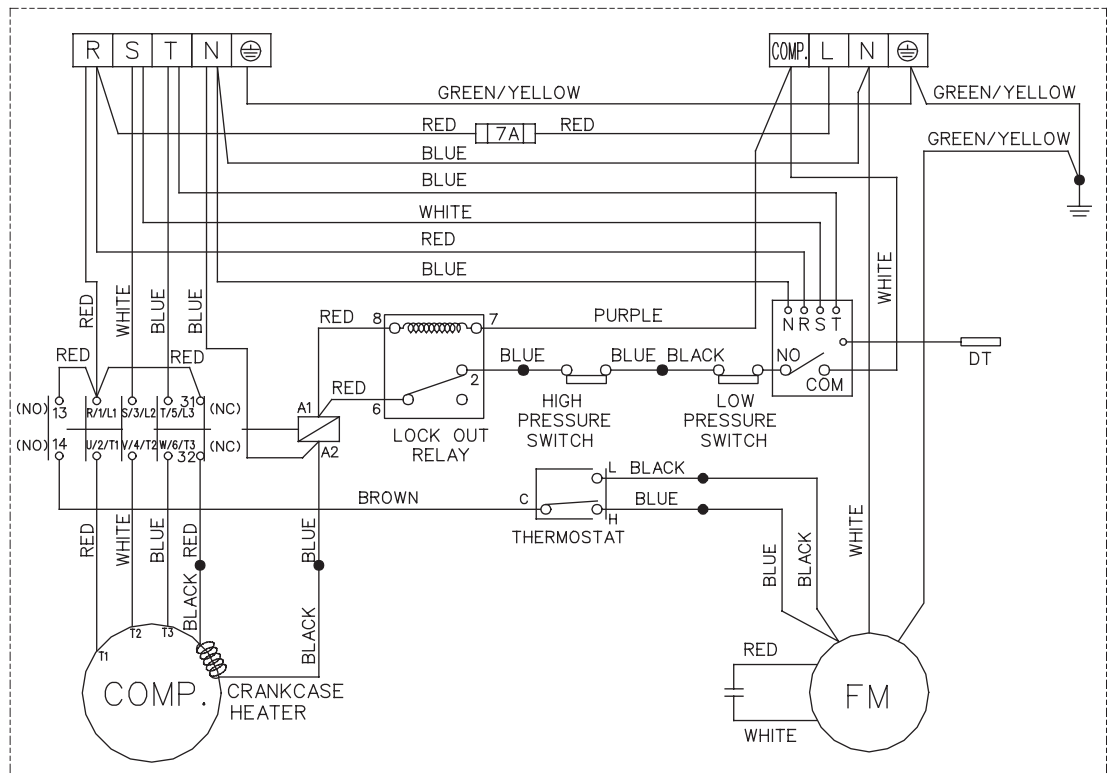

High Ambient Unit
Outdoor Unit
Model : MLC 030CR (Heatpump)
50Hz / 1 Phase / 220 ~ 240V

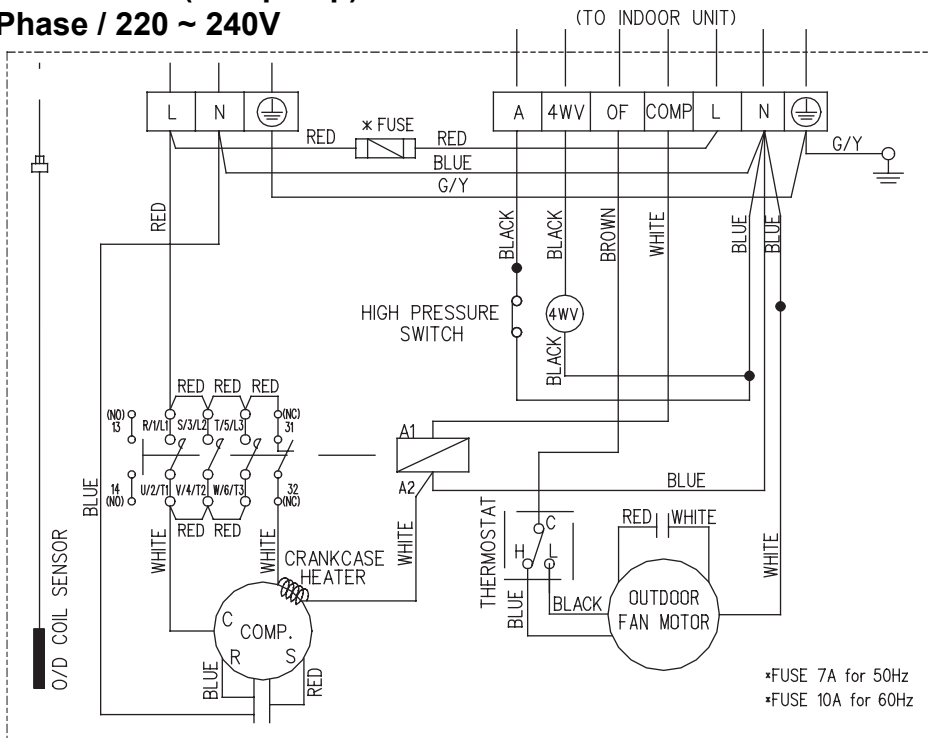

Outdoor Unit
Model : MLC 040 / 050CR (Heatpump)
50Hz / 3 Phase / 380 ~ 415V

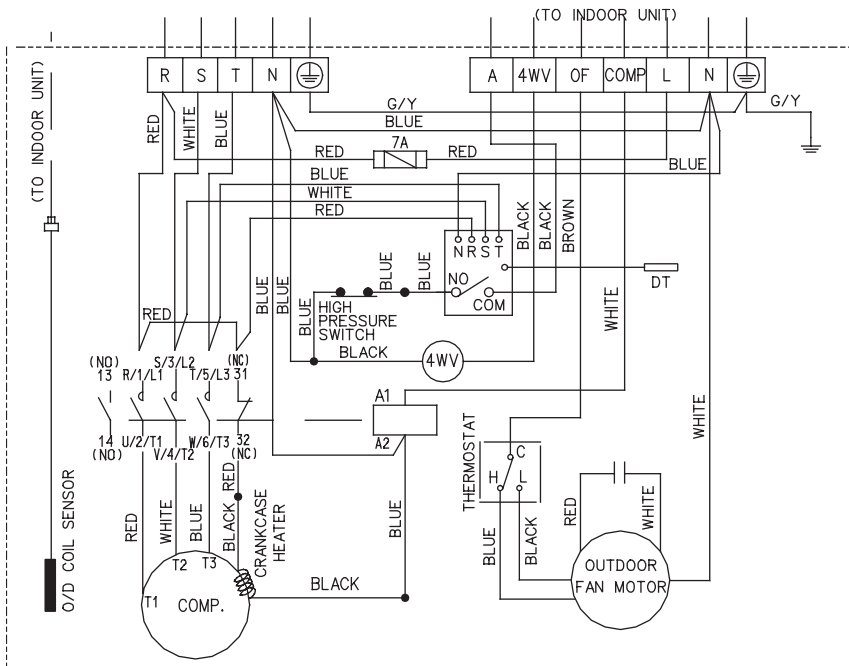

Outdoor Unit
Model : MLC 010C (Cooling only)
50Hz / 1 Phase / 220 ~ 240V

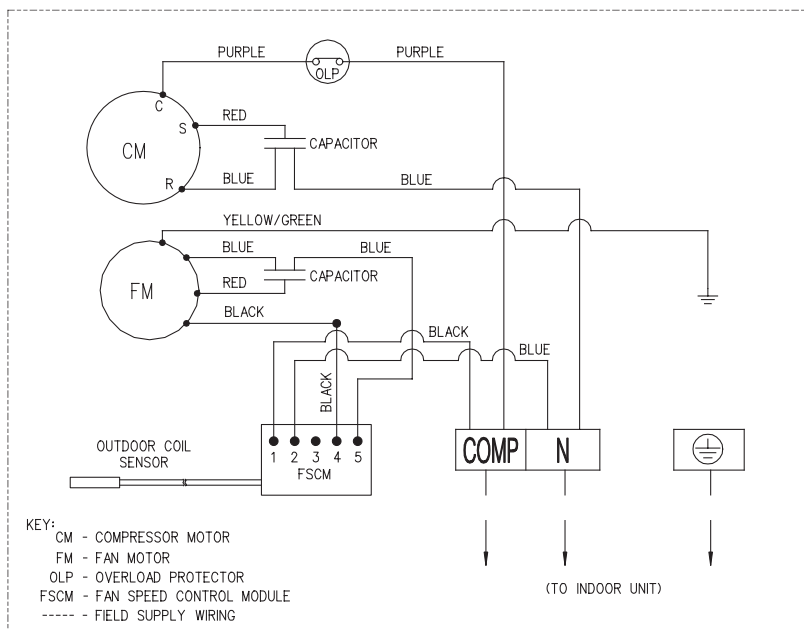

Low Ambient Unit
Outdoor Unit
Model : MLC 015C (Cooling only)
50Hz / 1 Phase / 220 ~ 240V

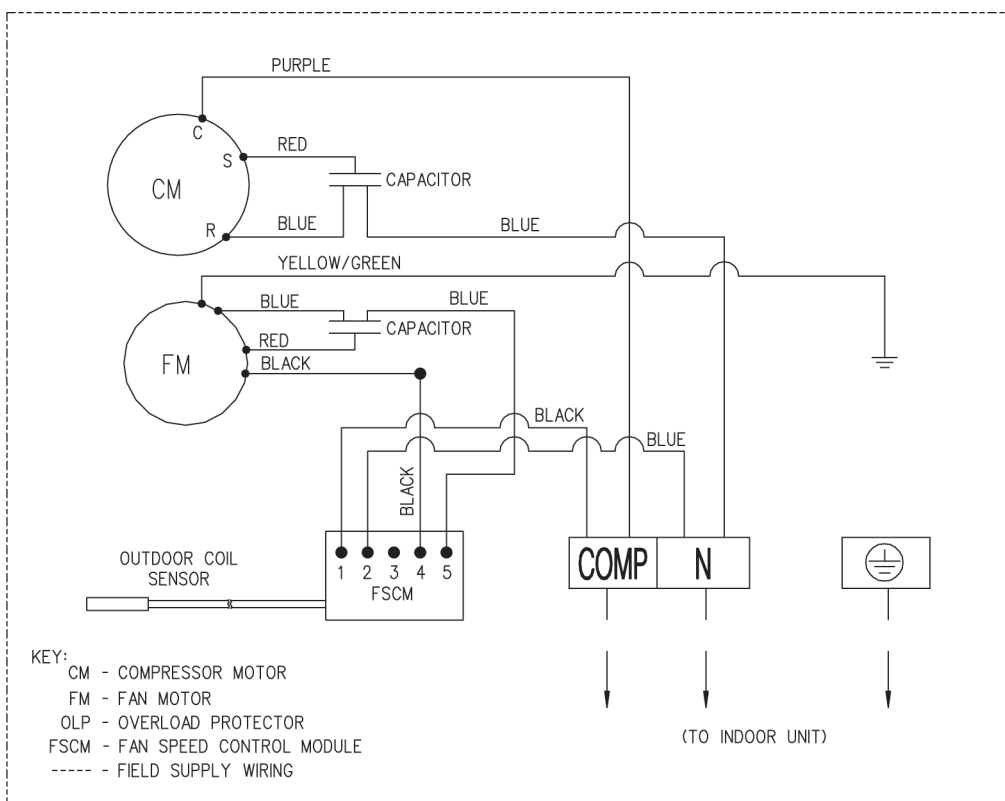

Servicing and Maintenance



Warning: Disconnect from main supply before servicing the air conditioner.

The unit is designed to give long life operation with minimum maintenance required. However, it should be regularly checked and the following items should be given due attention.

Components	Maintenance Procedure	Recommended Schedule
Air filter (Indoor Unit)	<ol style="list-style-type: none"> 1. Remove the ionizer filter before cleaning the filter. 2. Remove the dust adhering on the filter by using a vacuum cleaner or wash using water less than 40°C with a neutral cleaning detergent. 3. Rinse and dry it before fitting back the ionizer filter and set it back to unit. 4. Note : Never use petrol thinner, benzene or any other chemicals. 	At least once a month.
Indoor unit	<ol style="list-style-type: none"> 1. Clean away dirt or dust on grille or panel by wiping with soft cloth soaked in lukewarm (or cool) water or neutral detergent solution. 2. Note : Never use petrol, thinner, benzene or other volatile chemicals, which may cause plastic surface to deform. 	At least once a month.
Condense Drain Pan & Pipe	<ol style="list-style-type: none"> 1. Check the cleanliness and clean it if necessary. 2. Check the condensate water flow. 	Every 3 months.
Indoor Fan	Check if there is any abnormal noise.	If necessary.
Indoor/ Outdoor Coil	<ol style="list-style-type: none"> 1. Check and remove the dirt between the fins. 2. Check and remove any obstacles which hinder air flow through the indoor or outdoor. 	Every month.
Power Supply	<ol style="list-style-type: none"> 1. Check the running current and voltage for indoor and outdoor unit. 2. Check the electrical wiring and tighten the wire onto the terminal block if necessary. 	Every 2 months. Every year.
Compressor	No maintenance needed if refrigerant circuit remains sealed. However, check for refrigerant leak at joint and fitting.	Every 6 months.
Compressor Oil	Oil is factory charged. Not necessary to add oil if circuit remains sealed.	No maintenance required.
Fan Motor Oil	All motors are pre-lubricated and sealed at factory.	No maintenance required.

Pre Start Up Maintenance (After Extended Shutdown)

- Inspect thoroughly and clean indoor and outdoor units.
- Clean or replace air filters.
- Clean condensates drain line.
- Clean clogged indoor and outdoor coils.
- Check fan imbalance before operation.
- Tighten all wiring connections and panels.
- Check for refrigerant leakage.

For MLC Outdoor Models

The design of the MLC outdoor series allows servicing to be carried out easily. The removal of the top, front and side panels makes almost every part accessible.

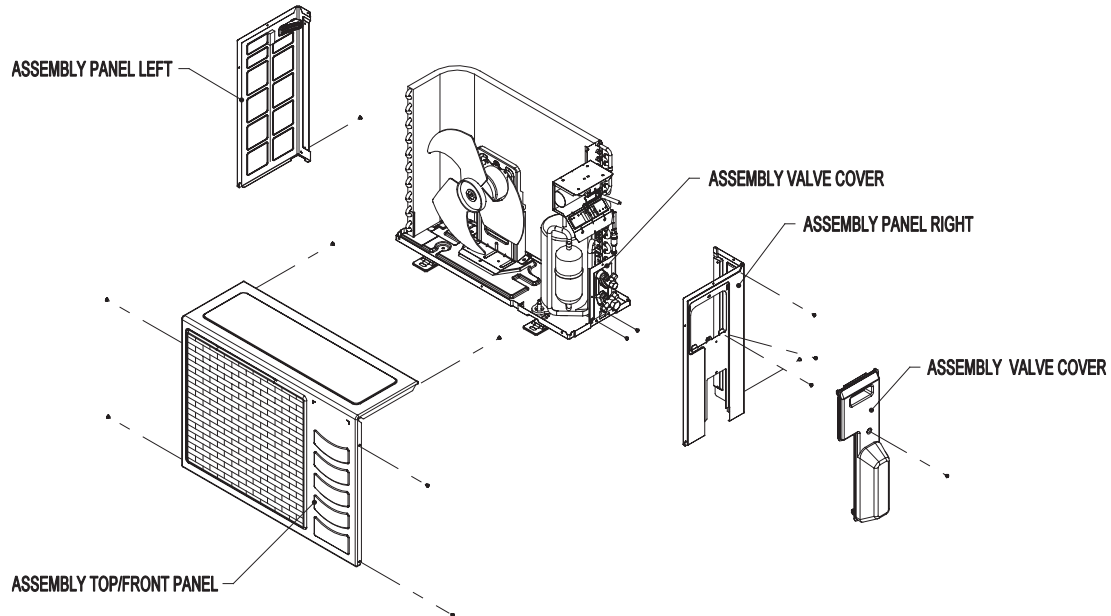

Under normal circumstances, these outdoor units only require a check and cleaning of air intake coil surface once every 3 months. However, if a unit is installed in areas subjected to much oil mist and dust, the coils must be regularly cleaned by qualified Air Conditioner Service Technicians to ensure sufficient heat exchange and proper operation. Otherwise, the systems life span may be shortened.

CAUTION!

Do not charge **OXYGEN, ACETYLENE OR OTHER FLAMMABLE** and poisonous gases into the unit when performing a leakage test or an air tight test. These gases could cause severe explosion and damage if expose to high temperature and pressure.
It is recommended that only nitrogen or refrigerant be charged when performing the leakage or airtight test.

Troubleshooting

When a malfunction of the air conditioner unit is detected, immediately switch off the main power supply before proceeding with the following troubleshooting procedures.

The following are common fault conditions and simple troubleshooting tips. If any other fault conditions which are not listed occur, contact your nearest local dealer. DO NOT attempt to troubleshoot the unit by yourself.

No	Fault conditions	Possible causes / corrective actions
1	The air conditioner unit will not resume after power failure.	<ul style="list-style-type: none"> The auto restart function is not functioning. Please turn on the unit with the wireless / wired controller.
2	The compressor does not operate 3 minutes after the air conditioner unit is started.	<ul style="list-style-type: none"> Protection against frequent starting. Wait for 3 or 4 minutes for the compressor to start operating by it self.
3	The airflow is too slow or room cannot be cooled sufficiently.	<ul style="list-style-type: none"> The air filter is dirty. The doors and windows are opened. The air suction and discharge of both indoor and outdoor units are clogged or blocked. The regulated temperature or temperature setting is not low enough.
4	Discharge airflow has bad odor.	<ul style="list-style-type: none"> Cigarettes, smoke particles, perfume and others, which might have adhered onto the coil, may cause odor. Contact your nearest dealer.
5	Condensation on the front air grille of the indoor unit.	<ul style="list-style-type: none"> This is caused by air humidity after an extended period of operation. The set temperature is too low. Increase the temperature setting and operate the unit at high fan speed.
6	Water flowing out from the air conditioner.	<ul style="list-style-type: none"> Switch off the unit and contact your nearest dealer. This might be due to tilted installation.
7	Hissing airflow sound from the air conditioner unit during operation.	<ul style="list-style-type: none"> Liquid refrigerant flowing into the evaporator coil.
8	The wireless controller display is dim.	<ul style="list-style-type: none"> The batteries are discharged. The batteries are not correctly inserted. The assembly is not good.
9	Compressor operates continuously.	<ul style="list-style-type: none"> Dirty air filter. Clean the air filter. Temperature setting too low (cooling). Use higher temperature setting. Temperature setting too high (heating), Use lower temperature setting.
10	No cool air comes out during cooling cycle, or no hot air comes out during heating cycle.	<ul style="list-style-type: none"> Temperature setting too high (cooling). Use lower temperature setting. Temperature setting too low (heating). Use higher temperature setting.
11	On heating cycle, warm air does not come out.	<ul style="list-style-type: none"> Unit is in defrost mode. Heating operation will resume after defrost cycle ends.

Diagnostic Guideliens

By means of pressure readings:

Data	Pressure					Probable cause
	Too low	A little low	Normal	A little high	Too high	
High side Low side					• •	<ol style="list-style-type: none"> Overcharged with refrigerant. Non-condensable gases in refrigerant circuit (e.g. air) Obstructed air-intake / discharge. Hot air short circuiting in outdoor unit.
High side Low side	•				•	<ol style="list-style-type: none"> Poor compression / no compression (compressor defective) Reversing valve leaking.
High side Low side	•	•				<ol style="list-style-type: none"> Undercharged with refrigerant. Refrigerant leakage. Air filter clogged / dirty (indoor unit). Indoor fan locked / seized. Defective defrost control, outdoor coil freeze up (heating). Outdoor fan locked / seized (heating).
High side Low side				•	•	<ol style="list-style-type: none"> Outdoor fan blocked (cooling). Outdoor coil dirty (cooling). Indoor fan locked / seized (heating). Indoor air filter clogged / dirty (heating). Non-condensable gases in refrigerant circuit (e.g. air)
High side Low side				•	•	<ol style="list-style-type: none"> Air intake temperature of indoor unit too high.

BY MEANS OF DIAGNOSTIC FLOW CHART :

Generally, there are two kinds of problems, i.e. starting failure and insufficient cooling/heating. “Starting failure” is caused by electrical defect while improper application or defects in refrigerant circuit causes “Insufficient cooling / heating”.

i) Diagnosis of Electric Circuit

The most common causes of air conditioner failure to “start” are :

- a) Voltage not within $\pm 10\%$ of rated voltage.
- b) Power supply interrupted.
- c) Improper control settings.
- d) Air conditioner is disconnected from main power source.
- e) Fuse blown or circuit breaker off.

ii) Diagnosis of Refrigerant Circuit / Application

There might be some causes where the unit starts running but does not perform satisfactorily, i.e. insufficient cooling. Judgement could be made by measuring temperature difference of indoor unit's intake and discharge air as well as running current.

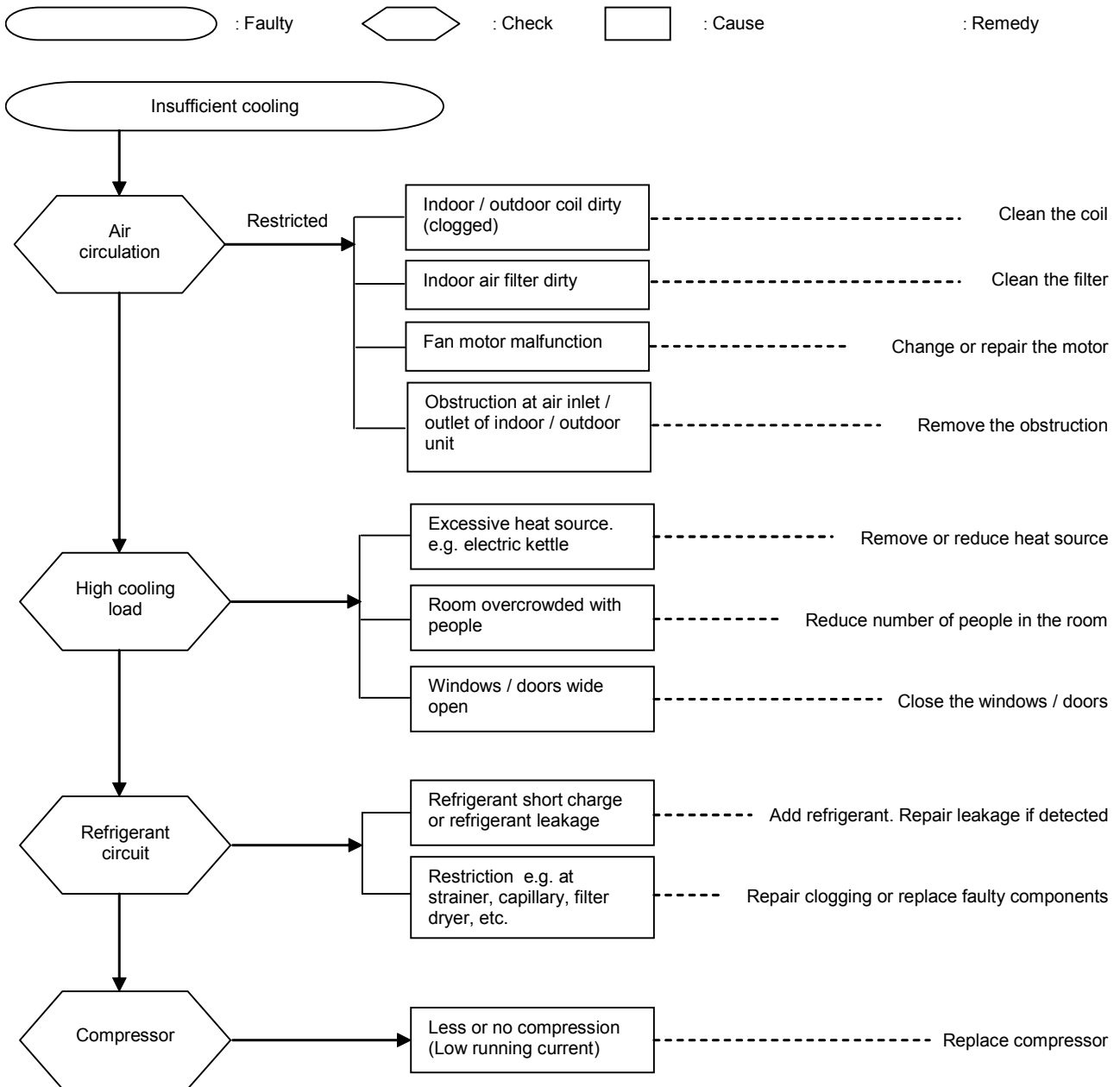

Satisfactory operation with temperature difference of air intake & discharge of indoor unit 8°C to 13°C. *
 (* value is for reference only)

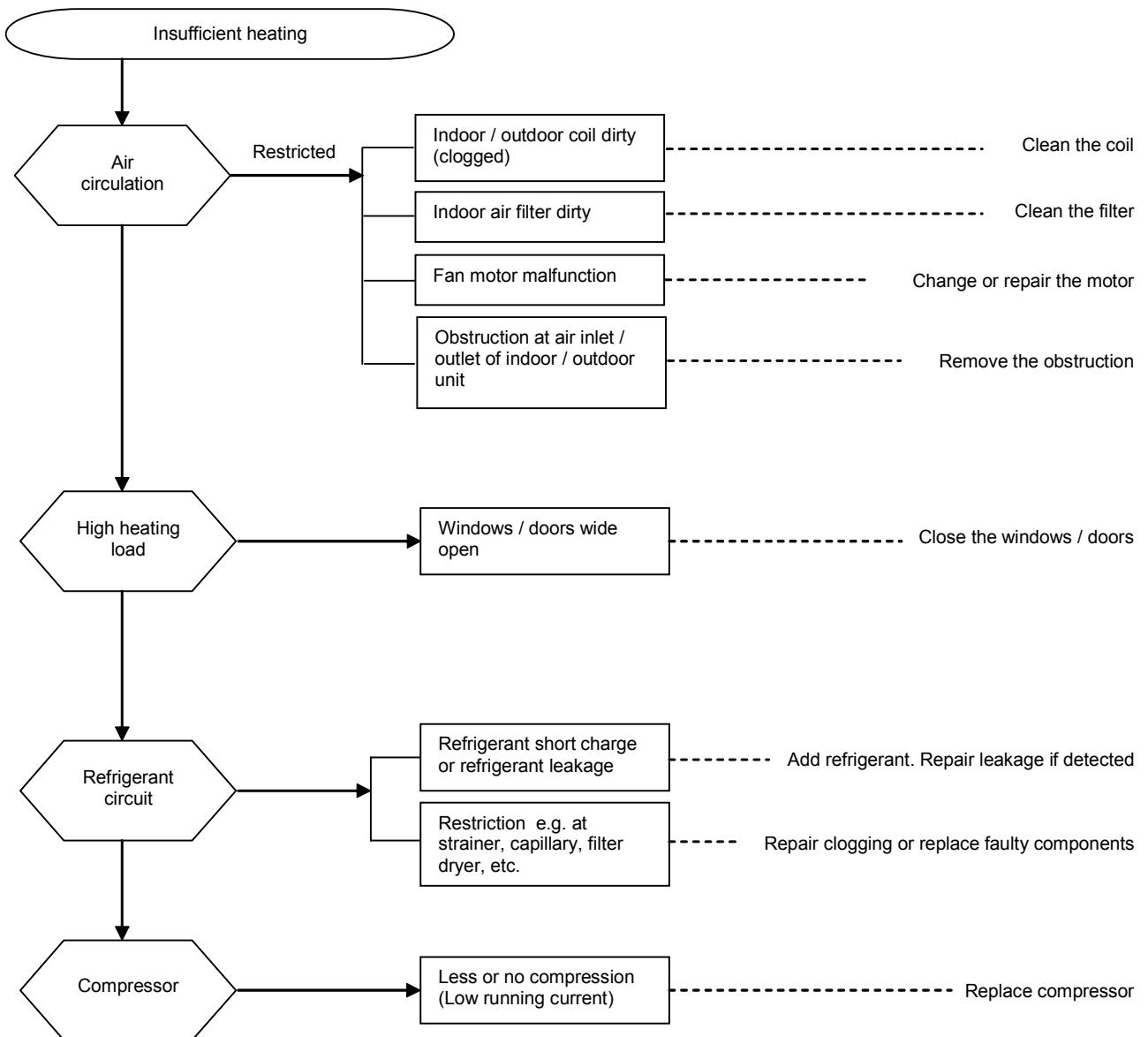

Satisfactory operation with temperature difference of air intake & discharge of indoor unit 14°C to 20°C. *
 (* value is for reference only)

Exploded View and Parts List

Model : MCC / M5LC 010C/CR

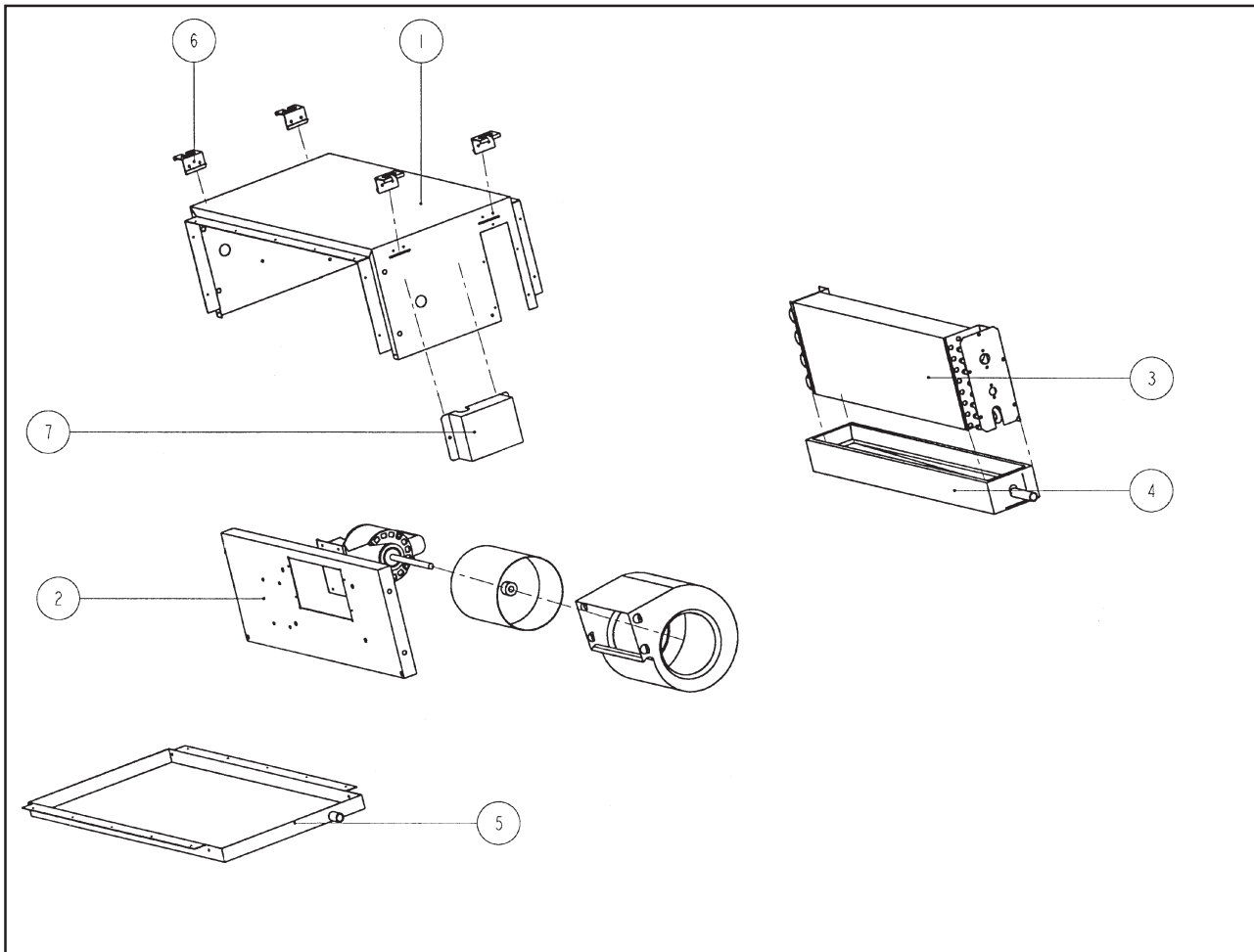

No	Description	Part No
1	Cabinet	R01013034004
2	Fan Deck	R50014032627
3	Assy., Coil MCC 010C/CR M5CC 010C/CR	R50024061750 R50024079383
4	Primary Drain Pan	R50063033907
5	Secondary Drain Pan	R50019009390
6	Hanger	R01014032372
7	-	-

No	Description	Part No
Parts Not in Diagram		
	Assy., Wheel & Housing	R50039005356
	Fan Motor	R03039004896
	Air Filter	R03084037810
	Assy., Drain Pipe Joint	R50094035451
	L2 Control Module MCC / M5CC 010C	R04089028159
	MCC / M5CC 010CR	R04089028158
	Handset SLM Cooling Only	R04089011809
	SLM Heat Pump	R04089011753

1) ALL SPECIFICATIONS ARE SUBJECT TO CHANGE BY THE MANUFACTURER WITHOUT PRIOR NOTICE

Model : MCC / M5CC 015 / 020 / 025C/CR

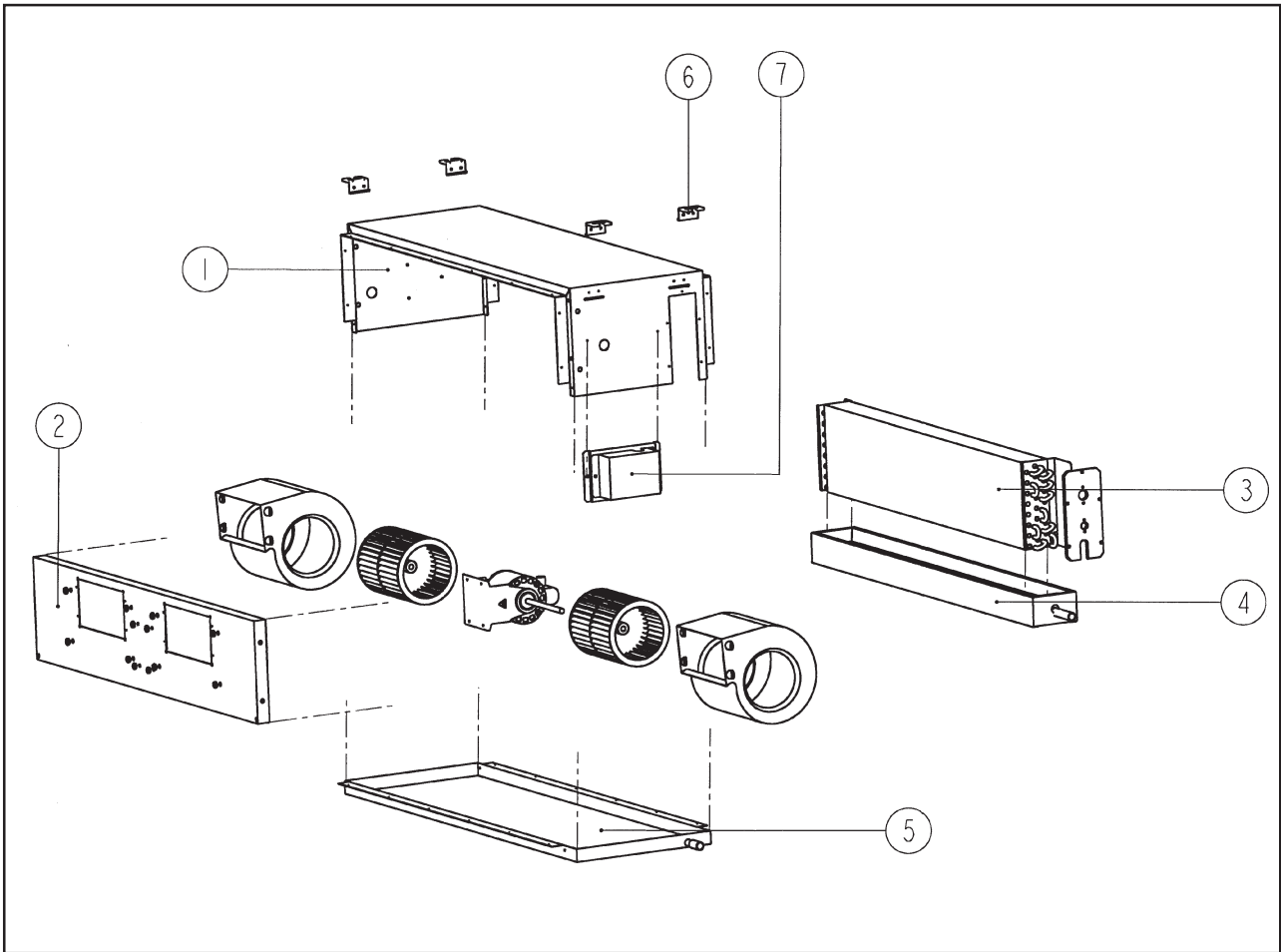

No	Description	Part No
1	Cabinet	
	MCC / M5CC 015C/CR	R01013032453
	MCC / M5CC 020C/CR	R01013034005
	MCC / M5CC 025C/CR	R01013032362
2	Fan Deck	
	MCC / M5CC 015C/CR	R50014032628
	MCC / M5CC 020C/CR	R50014035082
	MCC / M5CC 025C/CR	R50014032629
3	Assy., Coil	
	MCC 015C/CR	R50024061751
	M5CC 015C/CR	R50024079396
	MCC 020C/CR	R50024068698
	M5CC 020C/CR	R50024079268
	MCC 025C/CR	R50024061753
4	Primary Drain Pan	
	MCC / M5CC 015C/CR	R50063032460
	MCC / M5CC 020C/CR	R50063033908
	MCC / M5CC 025C/CR	R50063032369
5	Secondary Drain Pan	
	MCC / M5CC 015C/CR	R50019009402
	MCC / M5CC 020C/CR	R50019009407
	MCC / M5CC 025C/CR	R50019009420

No	Description	Part No
6	Hanger	R01014032372
7	-	-
Parts Not in Diagram		
	Assy., Wheel & Housing - Left	R50039005356
	Assy., Wheel & Housing - Right	R50039005355
	Fan Motor	
	MCC / M5CC 015C/CR	R03039004897
	MCC / M5CC 020C/CR	R03039004898
	MCC / M5CC 025C/CR	R03039004899
	Air Filter	
	MCC / M5CC 015C/CR	R03084037811
	MCC / M5CC 020C/CR	R03084037809
	MCC / M5CC 025C/CR	R03084037812
	Assy., Drain Pipe Joint	R50094035451
	L2 Control Module	
	MCC / M5CC 010C	R04089028159
	MCC / M5CC 010CR	R04089028158
	Handset	
	SLM Cooling Only	R04089011809
	SLM Heat Pump	R04089011753

1) ALL SPECIFICATIONS ARE SUBJECT TO CHANGE BY THE MANUFACTURER WITHOUT PRIOR NOTICE

Model : MCC / M5CC 028C/CR

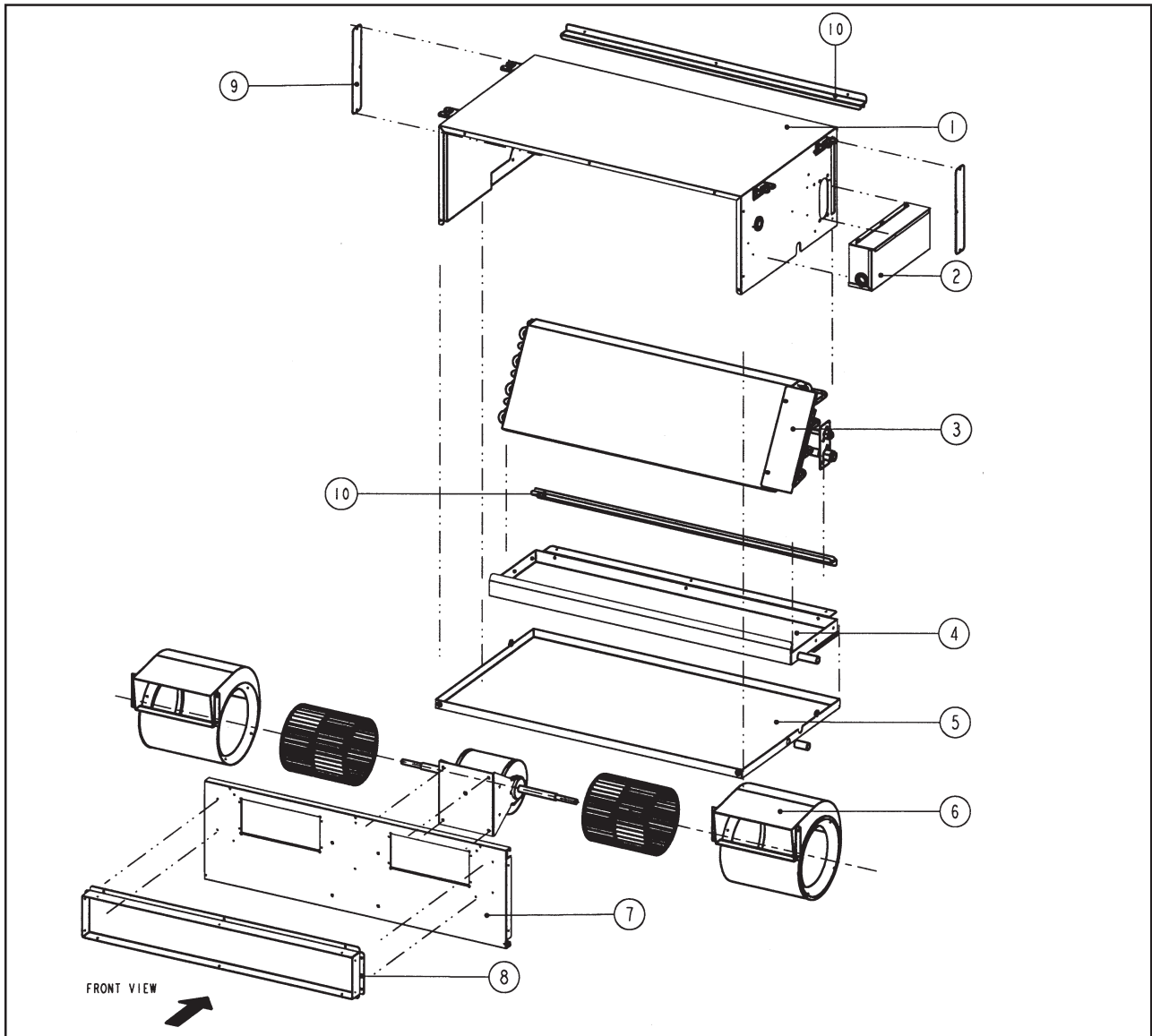

No	Description	Part No
1	Assy., Top Panel	R01014049252
2	-	-
3	Assy., Coil MCC 028C MCC 028CR M5CC 028C/CR	R50024049255 R50024052435 R50024080416
4	Assy., Drain Pan (Small)	R50015049248
5	Assy., Drain Pan (Big)	R50015049249
6	Assy., Wheel & Housing - Left Assy., Wheel & Housing - Right	R50034051182 R50034051183
7	Panel, Blower	R50014049251
8	Flange, Blower	R01014049296
9	Filter Rail, Cover	R01014049263

No	Description	Part No
10	Filter Rail	R12014070626
Parts Not in Diagram		
	Hanger	R01014032372
	Fan Motor	R03039014589
	Bracket, Motor	R01014049242
	Support, Bracket Motor	R01014072553
	Air Filter	R03084051684
	L2 Control Module MCC / M5CC 010C MCC / M5CC 010CR	R04089028159 R04089028158
	Handset SLM Cooling Only SLM Heat Pump	R04089011809 R04089011753

1) ALL SPECIFICATIONS ARE SUBJECT TO CHANGE BY THE MANUFACTURER WITHOUT PRIOR NOTICE

Model : MCC 030C/CR

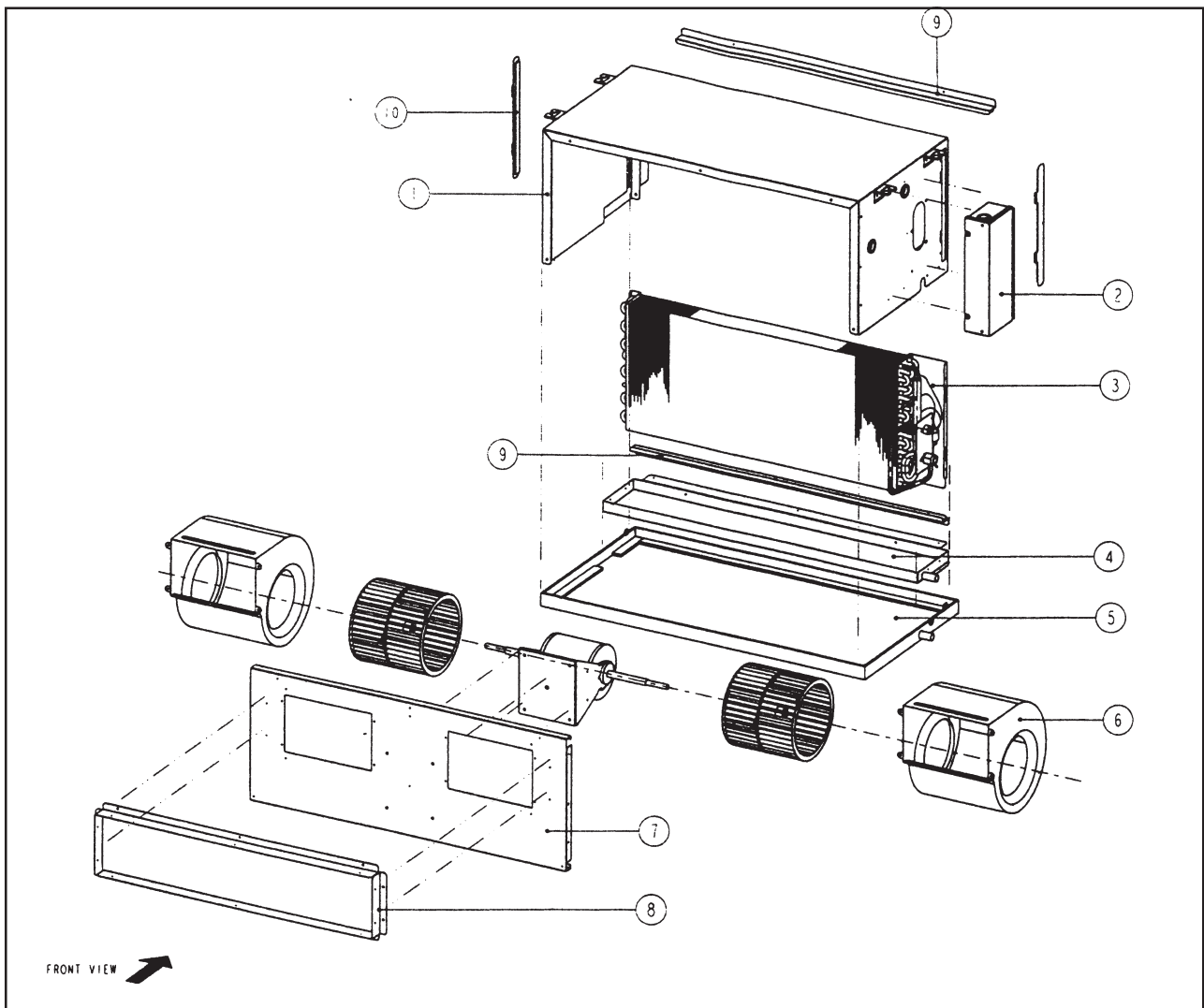

No	Description	Part No
1	Assy., Top Panel	R01014053420
2	-	-
3	Assy., Coil MCC 030C MCC 030CR	R50024053510 R50024053514
4	Assy., Drain Pan (Small)	R50019015283
5	Assy., Drain Pan (Big)	R50019015284
6	Assy., Wheel & Housing - Left Assy., Wheel & Housing - Right	R50034016257 R50034016083
7	Panel, Blower	R50014040253
8	Flange, Blower	R01014039130
9	Filter Rail, Cover	R01014039769
10	Filter Rail	R12014070627

No	Description	Part No
Parts Not in Diagram		
	Hanger	R01014032372
	Fan Motor	R03039014585
	Bracket, Motor	R01014045260
	Support, Bracket Motor	R01014072554
	Air Filter	R03084055531
	L2 Control Module MCC / M5CC 010C MCC / M5CC 010CR	R04089028159 R04089028158
	Handset SLM Cooling Only SLM Heat Pump	R04089011809 R04089011753

1) ALL SPECIFICATIONS ARE SUBJECT TO CHANGE BY THE MANUFACTURER WITHOUT PRIOR NOTICE

Model : MCC / M5CC 038C/CR

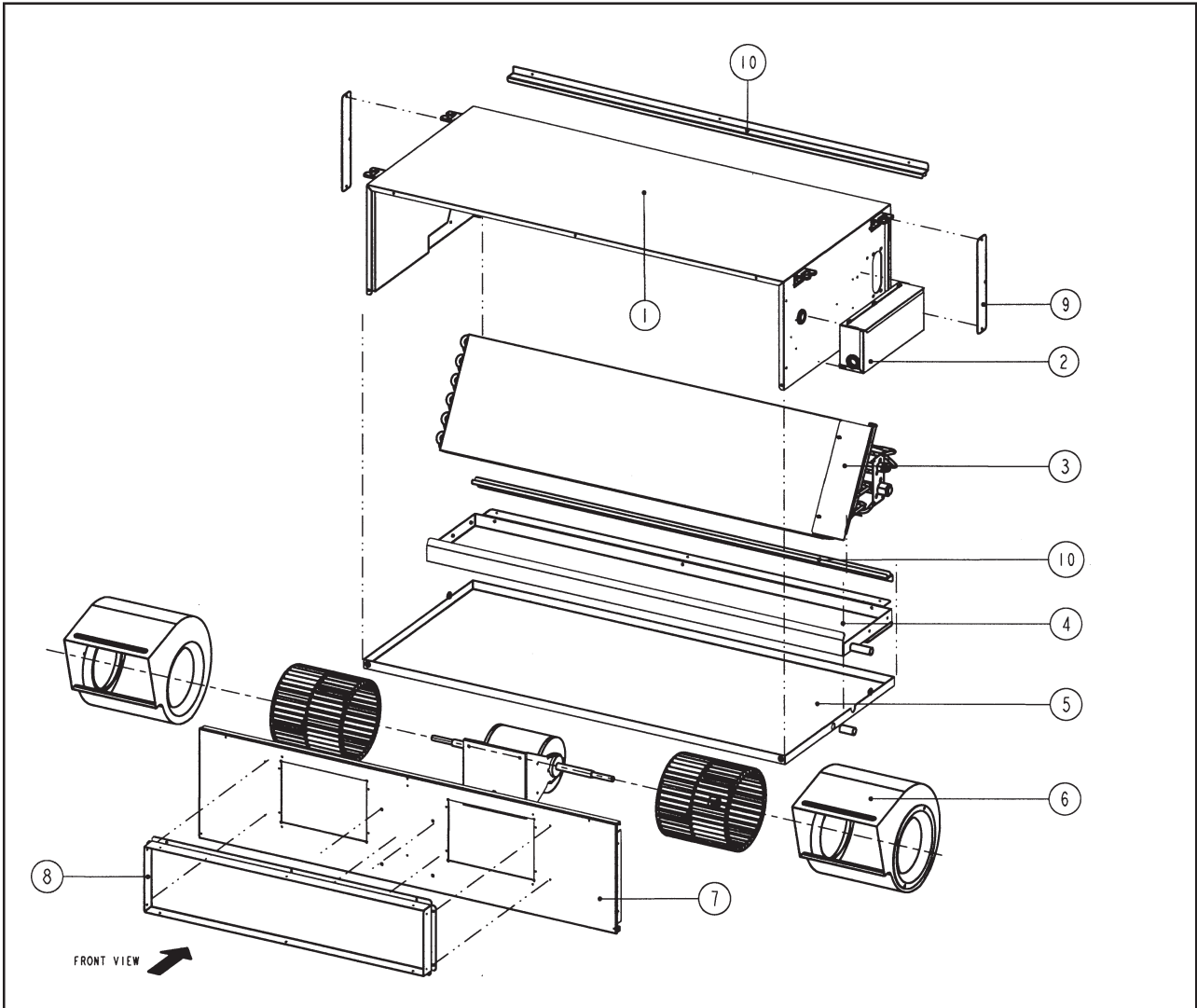

No	Description	Part No
1	Assy., Top Panel	R01014049376
2	-	-
3	Assy., Coil MCC 038C MCC 038CR M5CC 038C/CR	R50024052050 R50024052436 R50024093513
4	Assy., Drain Pan (Small)	R50015049390
5	Assy., Drain Pan (Big)	R50015049389
6	Assy., Wheel & Housing - Left Assy., Wheel & Housing - Right	R50034051693 R50034051694
7	Panel, Blower	R50014049388
8	Flange, Blower	R01014051674
9	Filter Rail, Cover	R01014049384
10	Filter Rail	R12014070628

No	Description	Part No
Parts Not in Diagram		
	Hanger	R01014032372
	Fan Motor	R03039014590
	Bracket, Motor	R01014051673
	Support, Bracket Motor	R01014045263
	Air Filter	R03084051708
	L2 Control Module MCC / M5CC 010C MCC / M5CC 010CR	R04089028159 R04089028158
	Handset SLM Cooling Only SLM Heat Pump	R04089011809 R04089011753

1) ALL SPECIFICATIONS ARE SUBJECT TO CHANGE BY THE MANUFACTURER WITHOUT PRIOR NOTICE

Model : MCC 040C/CR

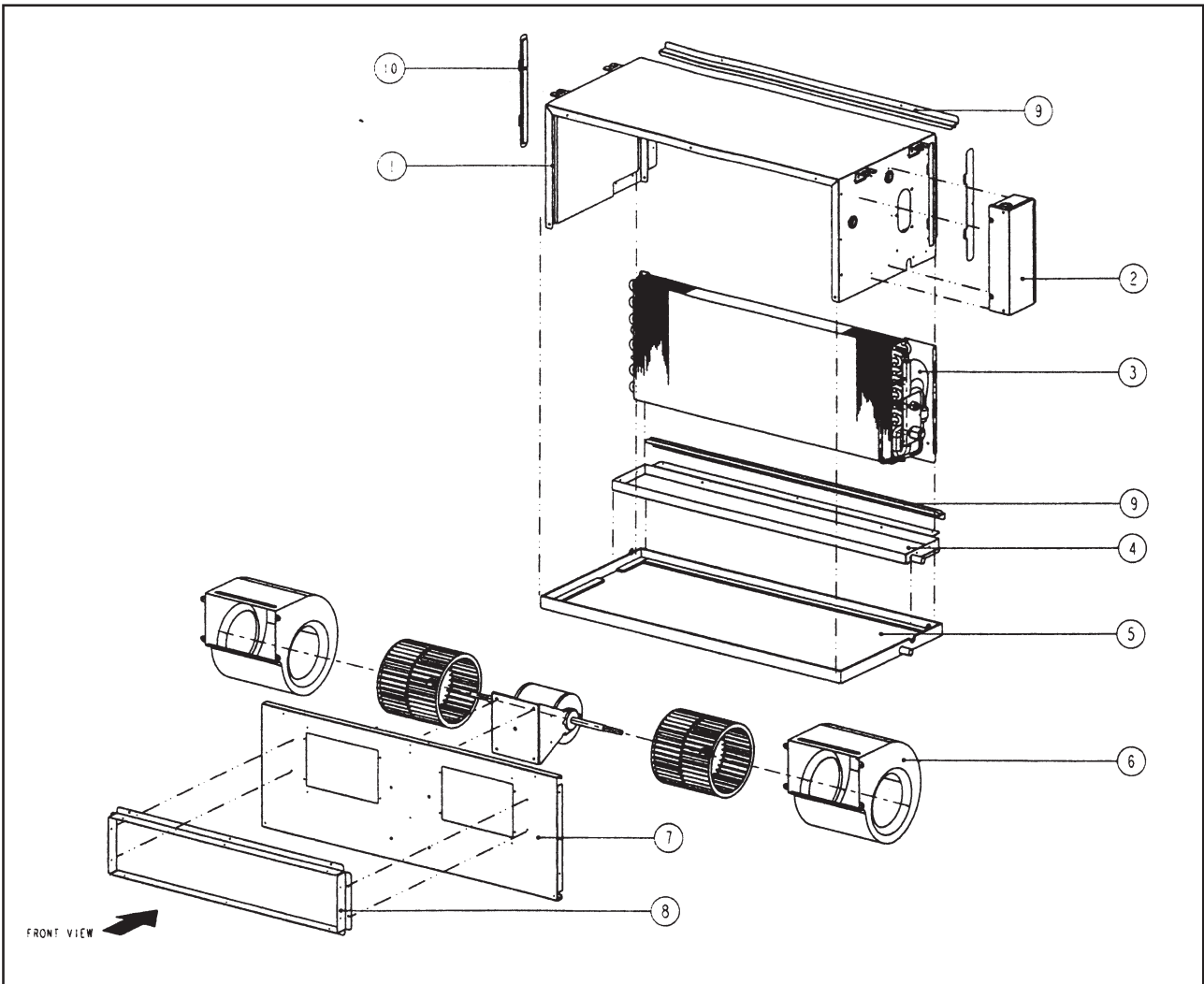

No	Description	Part No
1	Assy., Top Panel	R01014053435
2	-	-
3	Assy., Coil MCC 040C MCC 040CR	R50024053511 R50024053515
4	Assy., Drain Pan (Small)	R50019015287
5	Assy., Drain Pan (Big)	R50015049389
6	Assy., Wheel & Housing - Left Assy., Wheel & Housing - Right	R50034016257 R50034016083
7	Panel, Blower	R50014039926
8	Flange, Blower	R01014039130
9	Filter Rail, Cover	R01014039769
10	Filter Rail	R12014070629

No	Description	Part No
Parts Not in Diagram		
	Hanger	R01014032372
	Fan Motor	R03039014586
	Bracket, Motor	R01014045260
	Support, Bracket Motor	R01014072554
	Air Filter	R03084055532
	L2 Control Module MCC / M5CC 010C MCC / M5CC 010CR	R04089028159 R04089028158
	Handset SLM Cooling Only SLM Heat Pump	R04089011809 R04089011753

1) ALL SPECIFICATIONS ARE SUBJECT TO CHANGE BY THE MANUFACTURER WITHOUT PRIOR NOTICE

Model : MCC / M5CC 050C/CR

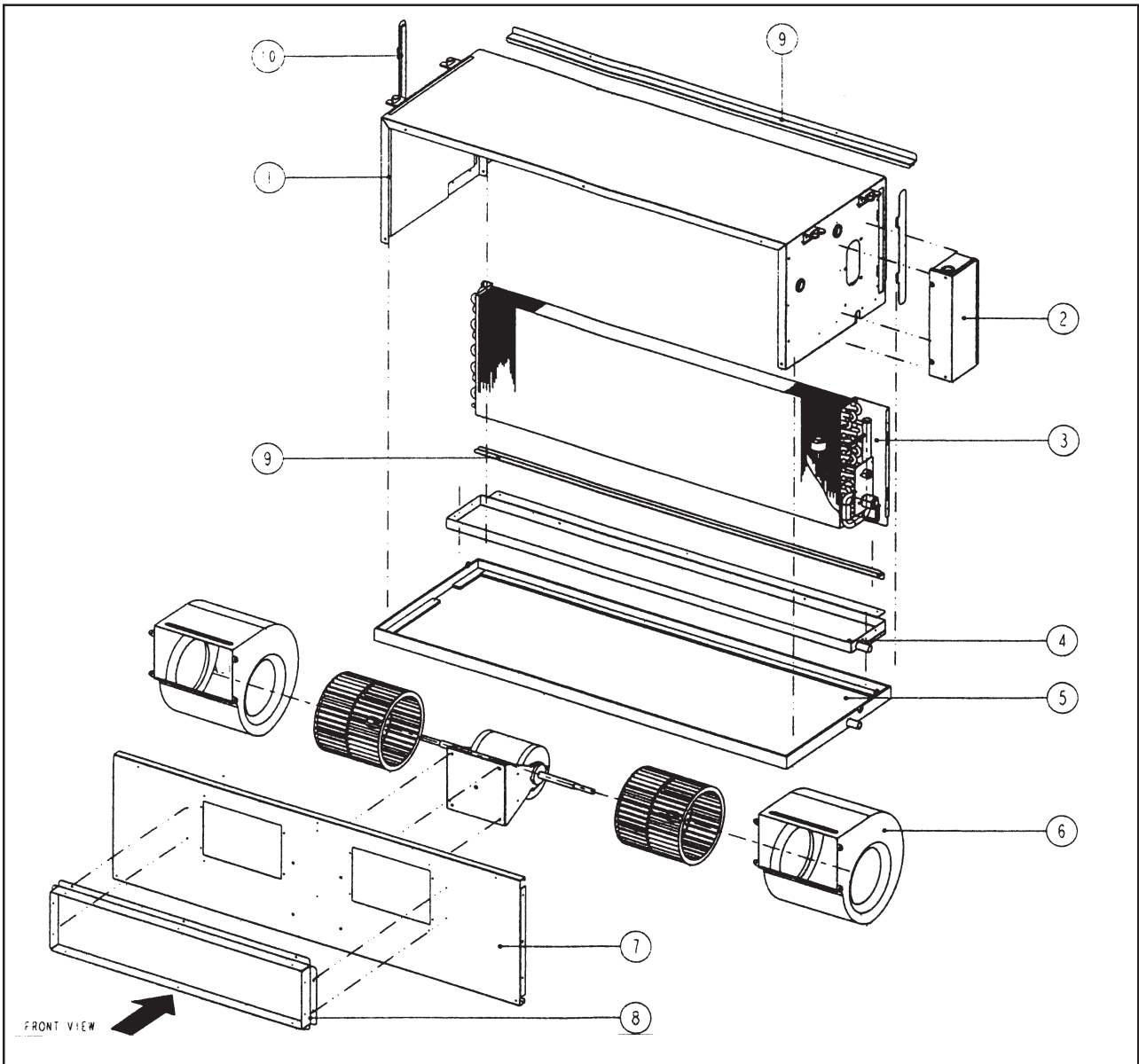

No	Description	Part No
1	Assy., Top Panel	R01014053446
2	-	-
3	Assy., Coil MCC 050C MCC 050CR M5CC 050C/CR	R50024071073 R50024053516 R50024090657
4	Assy., Drain Pan (Small)	R50019015291
5	Assy., Drain Pan (Big)	R50019015292
6	Assy., Wheel & Housing - Left Assy., Wheel & Housing - Right	R50034016258 R50034016084
7	Panel, Blower	R50014039137
8	Flange, Blower	R01014039130
9	Filter Rail, Cover	R01014039769

No	Description	Part No
10	Filter Rail	R12014070630
Parts Not in Diagram		
	Hanger	R01014032372
	Fan Motor	R03039014587
	Bracket, Motor	R01014045664
	Support, Bracket Motor	R01014072555
	Air Filter	R03084055533
	L2 Control Module MCC / M5CC 010C MCC / M5CC 010CR	R04089028159 R04089028158
	Handset SLM Cooling Only SLM Heat Pump	R04089011809 R04089011753

1) ALL SPECIFICATIONS ARE SUBJECT TO CHANGE BY THE MANUFACTURER WITHOUT PRIOR NOTICE

Model : MCC / M5CC 060C/CR

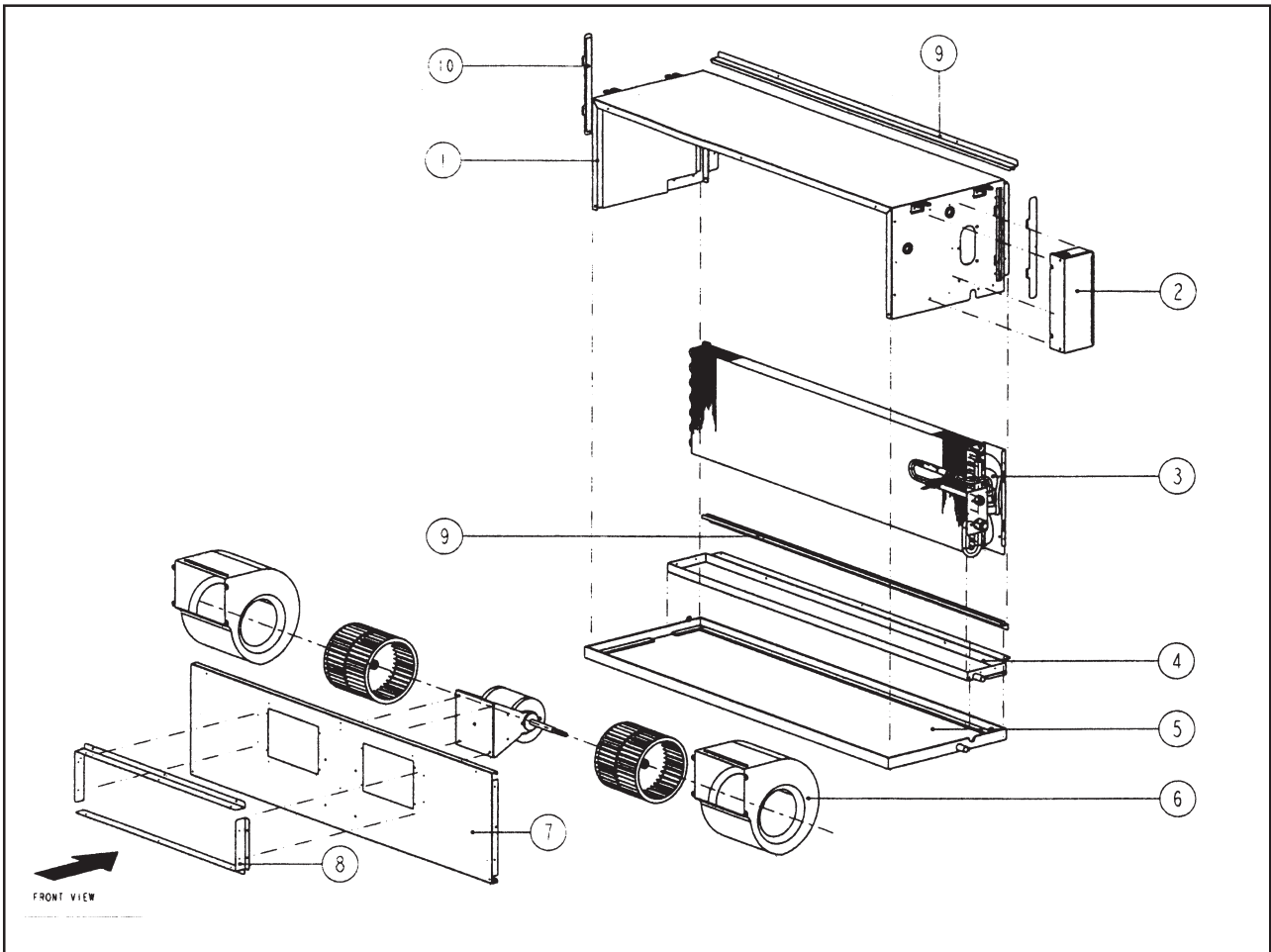

No	Description	Part No
1	Assy., Top Panel	R01014053482
2	-	-
3	Assy., Coil MCC 060C MCC 060CR M5CC 060C/CR	R50024053513 R50024053517 R50024090658
4	Assy., Drain Pan (Small)	R50019015295
5	Assy., Drain Pan (Big)	R50019015296
6	Assy., Wheel & Housing - Left Assy., Wheel & Housing - Right	R50034016258 R50034016084
7	Panel, Blower	R50014039022
8	Flange, Blower	R01014039130
9	Filter Rail, Cover	R01014039769
10	Filter Rail	R12014070631

No	Description	Part No
Parts Not in Diagram		
	Hanger	R01014032372
	Fan Motor	R03039014588
	Bracket, Motor	R01014045664
	Support, Bracket Motor	R01014072555
	Air Filter	R03084055534
	L2 Control Module MCC / M5CC 010C MCC / M5CC 010CR	R04089028159 R04089028158
	Handset SLM Cooling Only SLM Heat Pump	R04089011809 R04089011753

1) ALL SPECIFICATIONS ARE SUBJECT TO CHANGE BY THE MANUFACTURER WITHOUT PRIOR NOTICE

Model : MLC / M5LC 010 / 015C

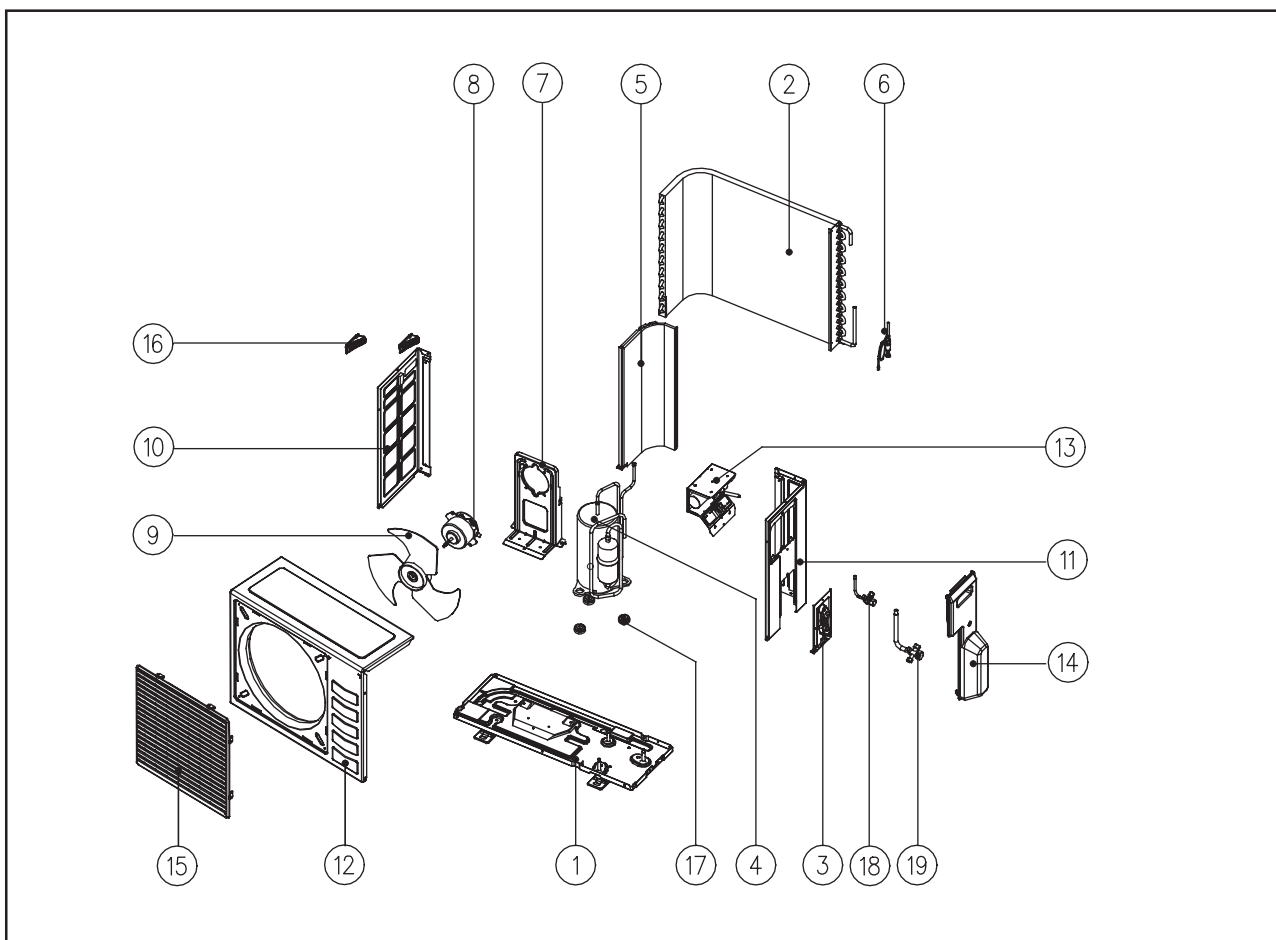

No	Description	Part No
1	Assy. Base Pan	R50014051158
2	Assy. Outdoor Coil	
	MLC 010C	A50024085384
	M5LC 010C	R50024083859
	MLC 015C	A50024087838
	M5LC 015C	R50024084998
3	Valve Bracket	R01014051164
4	Compressor	
	MLC 010C	R50049019551
	M5LC 010C	R50049019591
	MLC 015C	A04019027709
	M5LC 015C	R04019026326
5	Assy., Partition	R50064055063
6	Assy., Cap Tube	
	MLC 010C	R50024085382
	M5LC 010C	R50024084026
	MLC / M5LC 015C	R50024087757
7	Bracket, Fan Motor	R01014051162
8	Fan Motor	
	MLC / M5LC 010C	R03039016104
	MLC / M5LC 015C	R03039015323
9	Fan Blade	R03019015339
10	Left Panel	R01014051166

No	Description	Part No
11	Right Panel	R01014051167
12	Assy., Front Panel	R01014051171
13	Assy., Control Panel	R50044086056
14	Assy., Valve Cover	R50124051173
15	Assy., Front Grille	R50124056700
16	Plastic Handle	R12014057948
17	Rubber Grommet	R11054000271
18	Assy., Flare Valve 2 Ways 1/4"	
	MLC 010/015C	R50054054950
	M5LC 010/015C	R50059019453
19	Assy., Flare Valve 3 Ways 3/8"	
	MLC 010C	R50054054951
	M5LC 010C	R50059019454
	Assy., Flare Valve 3 Ways 1/2"	
	MLC 015C	R50054064042
	M5LC 015C	R50059019452
Parts Not in Diagram		
	Capacitor, Fan Motor	R04029026755
	Capacitor, Compressor	
	MLC 010C	A04024012931
	M5LC 010C	R04029026774
	MLC 015C	R04029026775
	M5LC 015C	R04029026776

1) ALL SPECIFICATIONS ARE SUBJECT TO CHANGE BY THE MANUFACTURER WITHOUT PRIOR NOTICE

Model : MLC / M5LC 010 / 015CR

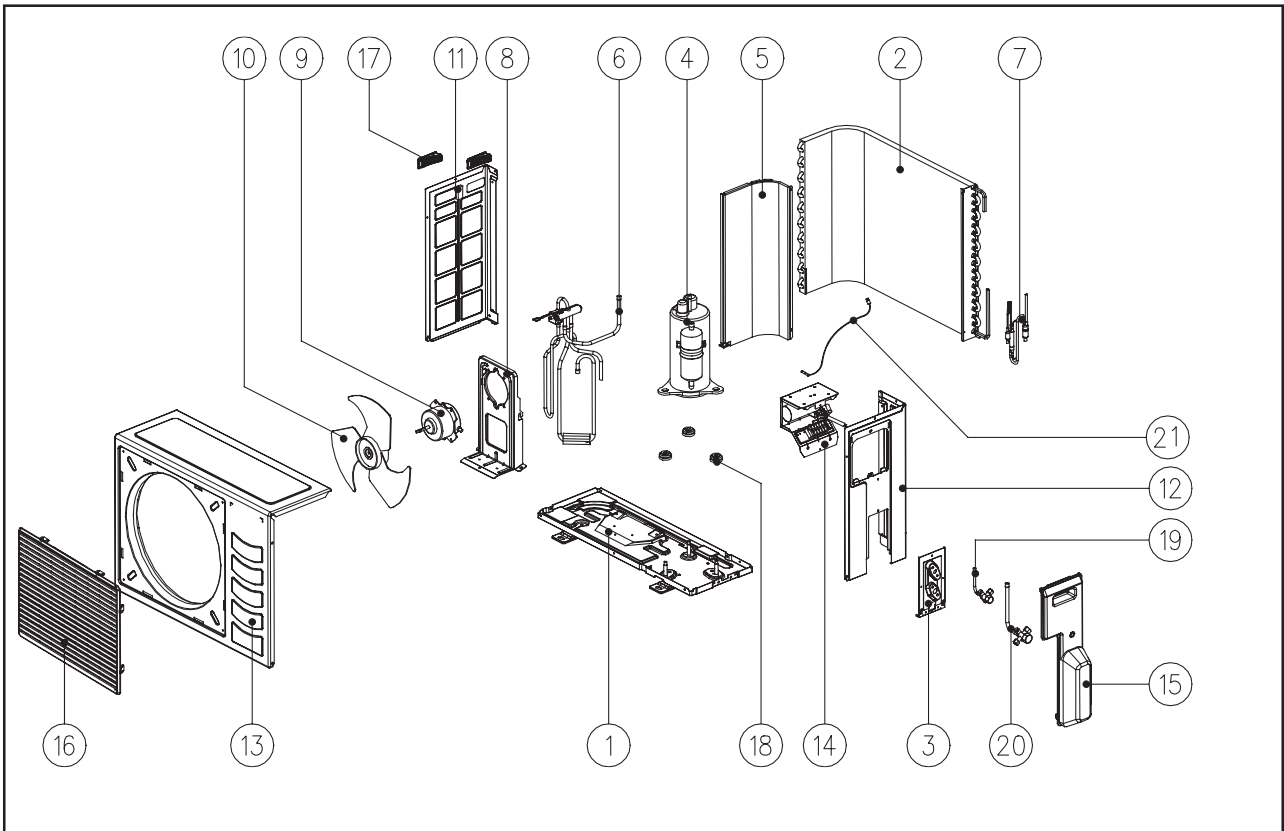

No	Description	Part No
1	Assy. Base Pan	R50014051158
2	Assy. Outdoor Coil	
	MLC 010CR	A50024085384
	M5LC 010CR	R50024083859
	MLC 015CR	A50024086953
	M5LC 015CR	R50024084998
3	Valve Bracket	R01014051164
4	Compressor	
	MLC 010CR	R50049019551
	M5LC 010CR	R50049019591
	MLC 015CR	R04019019125
	M5LC 015CR	R04019026326
5	Assy., Partition	R50064055063
6	Assy., 4 Way Valve	
	MLC 010CR	R05019004157
	M5LC 010CR	R05019016936
	MLC 015CR	A50024087158
	M5LC 015CR	R50024084737
7	Assy., Cap Tube	
	MLC 010CR	R50024085462
	M5LC 010CR	R50024083856
	MLC 015CR	A50024087023
	M5LC 015CR	R50024084738
8	Bracket, Fan Motor	R01014051162
9	Fan Motor	
	MLC / M5LC 010C	R03039016104
	MLC / M5LC 015C	R03039015323

No	Description	Part No
10	Fan Blade	R03019015339
11	Left Panel	R01014051166
12	Right Panel	R01014051167
13	Assy., Front Panel	R01014051171
14	Assy., Control Panel	R50044086063
15	Assy., Valve Cover	R50124051173
16	Assy., Front Grille	R50124056700
17	Plastic Handle	R12014057948
18	Rubber Grommet	R11054000271
19	Assy., Flare Valve 2 Ways 1/4"	
	MLC 010/015CR	R50054054950
	M5LC 010/015CR	R50059019453
20	Assy., Flare Valve 3 Ways 3/8"	
	MLC 010CR	R50054054951
	M5LC 010CR	R50059019454
	Assy., Flare Valve 3 Ways 1/2"	
	MLC 015CR	R50054064042
	M5LC 015CR	R50059019452
21	Sensor, Outdoor Defrost	R50134039416

Parts Not in Diagram

	Capacitor, Fan Motor	R04029026755
	Capacitor, Compressor	
	MLC 010C	A04024012931
	M5LC 010C	R04029026774
	MLC 015C	R04029026775
	M5LC 015C	R04029026776

1) ALL SPECIFICATIONS ARE SUBJECT TO CHANGE BY THE MANUFACTURER WITHOUT PRIOR NOTICE

Model : MLC 018 / 020C, M5LC 020C

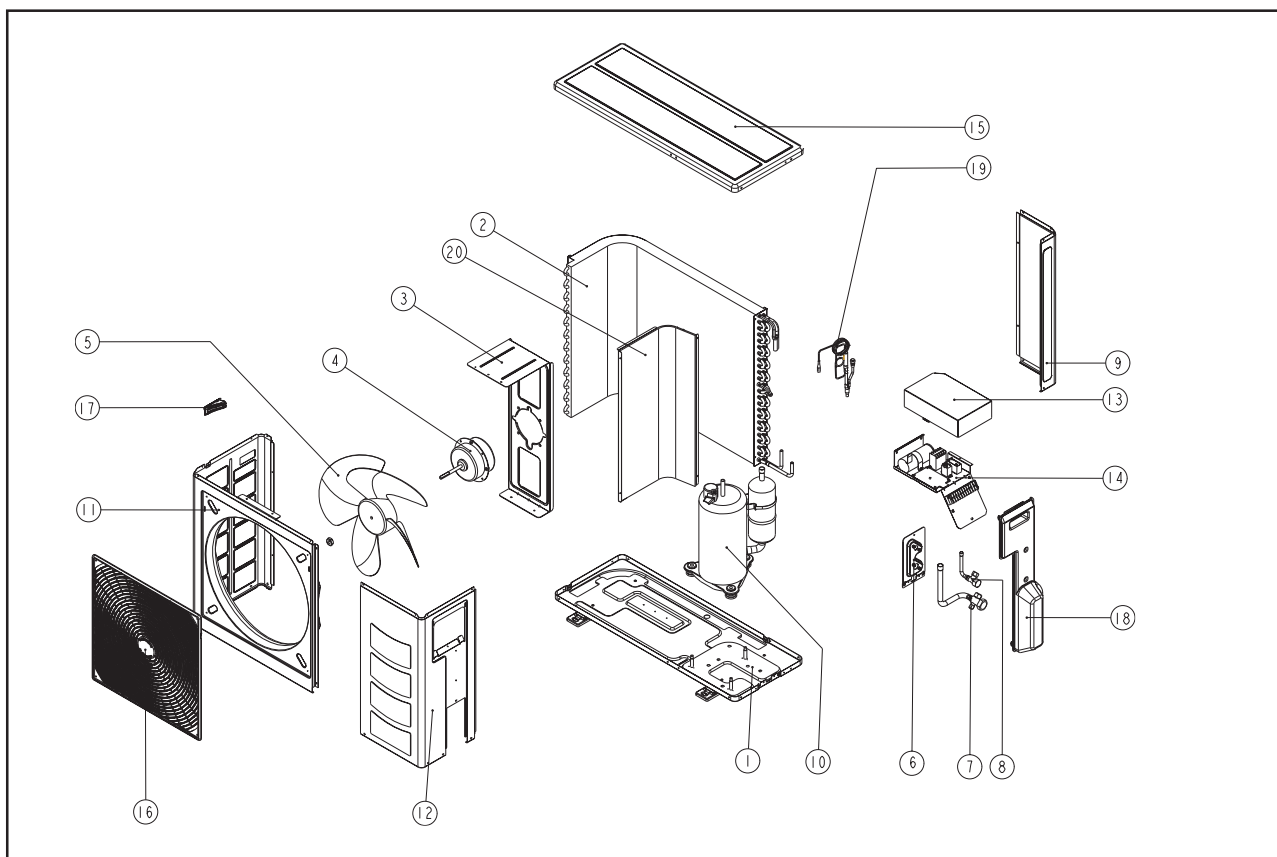

No	Description	Part No
1	Assy. Base Pan	R50014078281
2	Assy. Outdoor Coil MLC 018C MLC 020C M5LC 020C	R50024089940 A50024084570 R50024079078
3	Motor Bracket	R01014070601
4	Fan Motor	R03039024539
5	Fan Blade	R03019023393
6	Valve Bracket MLC 018/020C M5LC 020C	A50014072861 R50014078280
7	MLC 018/020C Assy. Flare Valve 3 Ways 5/8" M5LC 020C Assy. Flare Valve 3 Ways 1/2"	R50054072863 R50059023335
8	Assy. Flare Valve 2 Ways 1/4" MLC 018/020C M5LC 020C	R50059022156 R50059023334
9	Back Panel, Right	R01014070599

No	Description	Part No
10	Compressor MLC 018/020C M5LC 020C	A04019027266 R04019020625
11	Front Panel, Left	R01014070597
12	Service Panel	R01014070598
13	Terminal Cover Panel	R01014070838
14	Assy. Control Panel	R50014072877
15	Top Panel	R01014070596
16	Assy. Front Grille	R50124072880
17	Plastic Handle	R12014057948
18	Assy. Valve Cover	R50124072885
19	Assy. Cap Tube MLC 018C MLC 020C M5LC 020C	R50024089926 A50024087066 R50024081921
20	Partition	R01014070603

Parts Not in Diagram

	Capacitor, Fan Motor	R04029026759
	Capacitor, Compressor MLC 018/020C M5LC 020C	R04029026782 R04029026779

1) ALL SPECIFICATIONS ARE SUBJECT TO CHANGE BY THE MANUFACTURER WITHOUT PRIOR NOTICE

Model : MLC / M5LC 025C, MLC 028C

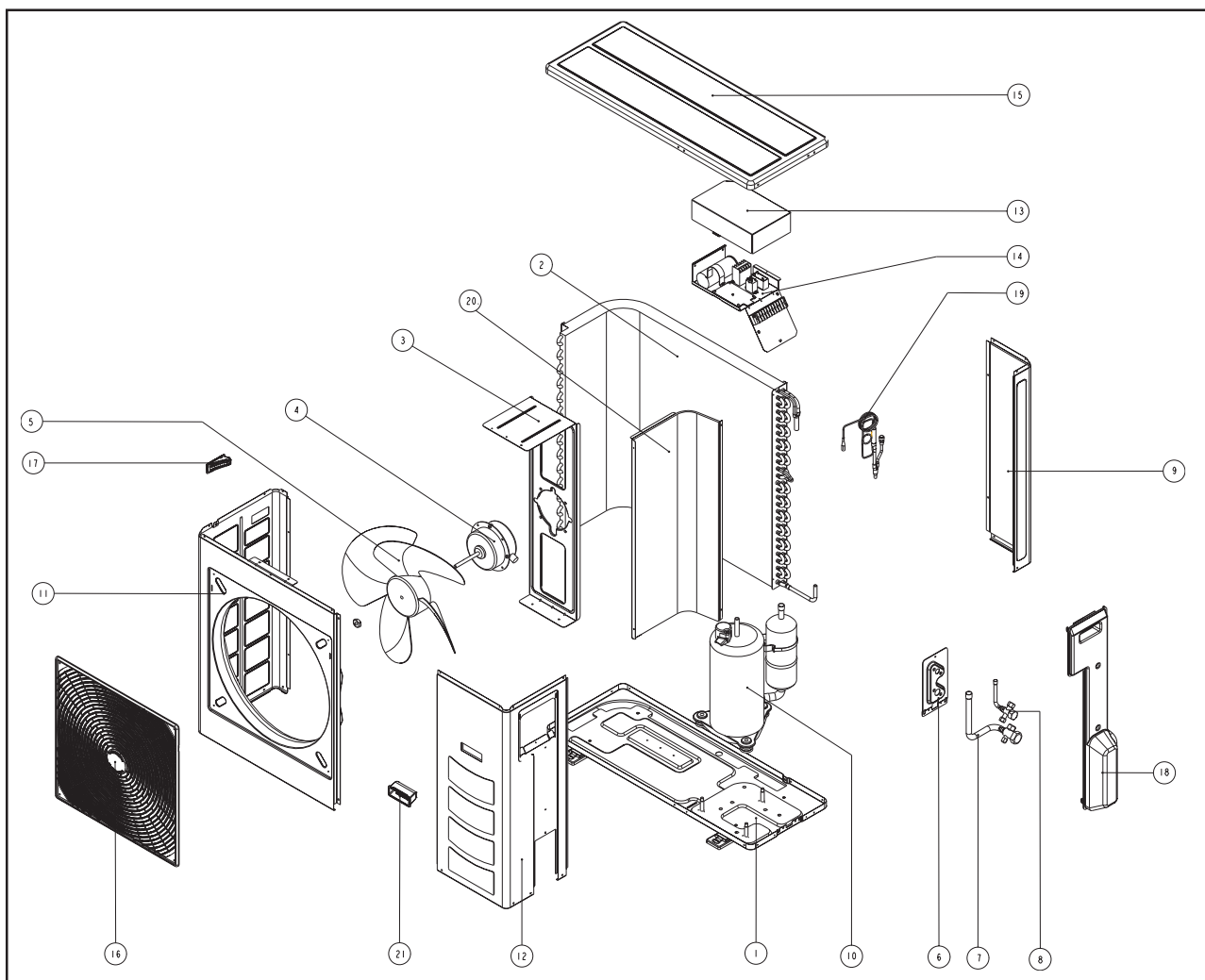

No	Description	Part No
1	Assy. Base Pan	R50014073884
2	Assy. Outdoor Coil MLC 025C M5LC 025/028C MLC 028C	R50024089206 R50024079238 A50024070959
3	Motor Bracket	R01014070948
4	Fan Motor MLC 025C M5LC 025C MLC / M5LC 028C	R03039028207 R03039023391 R03039024538
5	Fan Blade	R03019023393
6	Valve Bracket MLC 025/028C M5LC 025C M5LC 028C	A50014073890 R50014078321 R50014080371
7	Assy. Flare Valve 3 Ways 5/8" MLC 025/028C M5LC 025/028C	R50054072863 R50059023336
8	MLC 025/028C Assy. Flare Valve 3 Ways 3/8" M5LC 025C Assy. Flare Valve 2 Ways 1/4" M5LC 028C Assy. Flare Valve 3 Ways 3/8"	R50059022577 R50059023334 R50059024820
9	Back Panel, Right	R01014070950

No	Description	Part No
10	Compressor MLC 025C M5LC 025C MLC 028C M5LC 028C	A04019027570 R04019021361 R04019012828 R04019020449
11	Front Panel, Left	R01014070947
12	Service Panel	R01014070949
13	Terminal Cover Panel	A01014070838
14	Assy. Control Panel MLC / M5LC 025C MLC 028C M5LC 028C	R50044086076 R50044086137 R50044086138
15	Top Panel	R01014070596
16	Assy. Front Grille	R50124072880
17	Plastic Handle, Side	R12014057948
18	Assy. Valve Cover	R50124073905
19	Assy. Cap Tube MLC 025C M5LC 025C M5LC 028C	R50024090095 R50024081916 R50024079593
20	Partition	R01014070951
21	Plastic Handle, Front	R12014070955

Parts Not in Diagram

	Capacitor, Fan Motor MLC / M5LC 025C MLC / M5LC 028C	R04029026759 R04029026966
	Capacitor, Compressor MLC / M5LC 025C, MLC 028C M5LC 028C	R04029026779 R04029026778

1) ALL SPECIFICATIONS ARE SUBJECT TO CHANGE BY THE MANUFACTURER WITHOUT PRIOR NOTICE

Model : MLC / M5LC 020CR, MLC 018CR

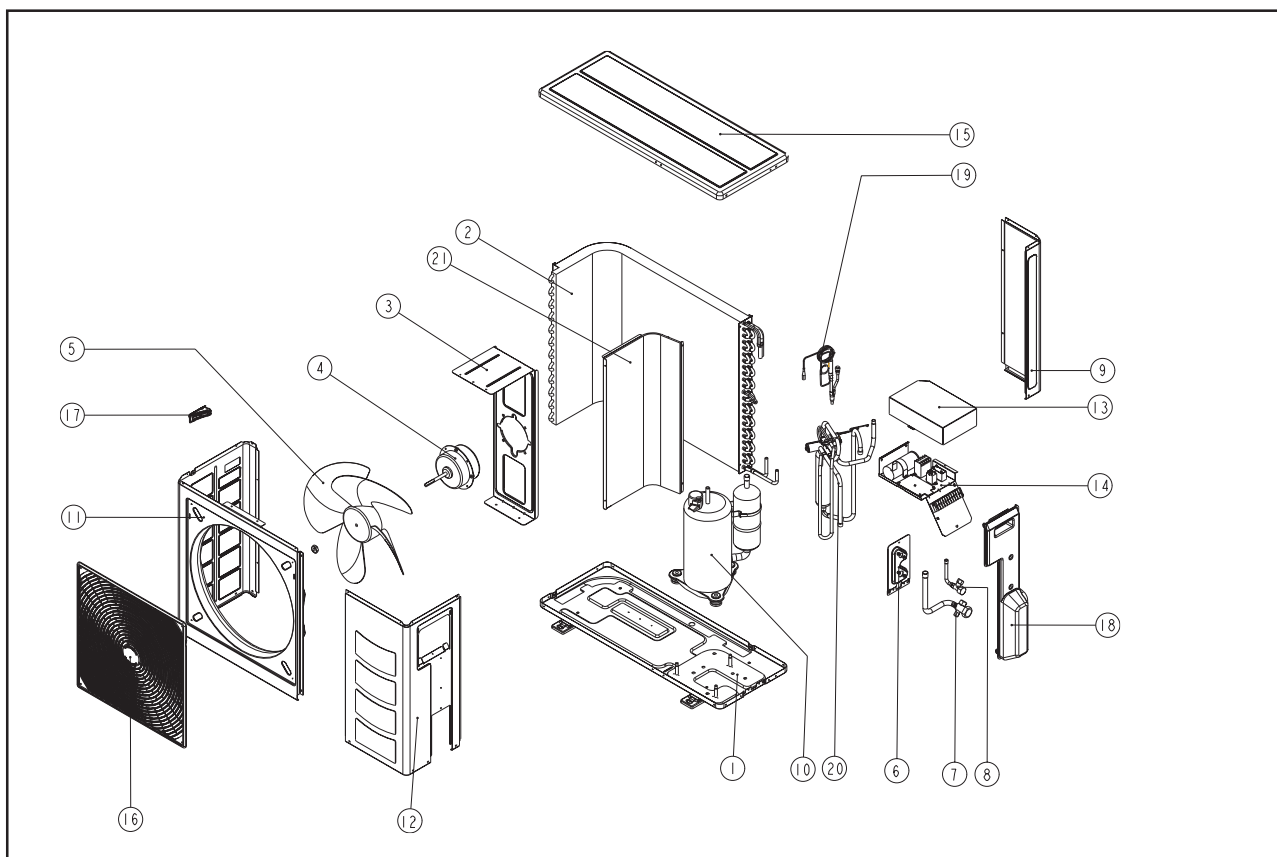

No	Description	Part No
1	Assy. Base Pan	R50014078281
2	Assy. Outdoor Coil MLC 018CR MLC / M5LC 020CR	R50024090296 R50024075143
3	Motor Bracket	R01014070601
4	Fan Motor	R03039024539
5	Fan Blade	R03019023393
6	Valve Bracket MLC 018/020CR M5LC 020CR	A50014072861 R50014078280
7	MLC 018/020CR Assy. Flare Valve 3 Ways 5/8" M5LC 020CR Assy. Flare Valve 3 Ways 1/2"	R50054072863 R50059023335
8	Assy. Flare Valve 2 Ways 1/4" MLC 018/020CR M5LC 020CR	R50059022156 R50059023334
9	Back Panel, Right	R01014070599
10	Compressor MLC 018/020CR M5LC 020CR	A04019027266 R04019020625

No	Description	Part No
11	Front Panel, Left	R01014070597
12	Service Panel	R01014070598
13	Terminal Cover Panel	R01014070838
14	Assy. Control Panel	R50014072877
15	Top Panel	R01014070596
16	Assy. Front Grille	R50124072880
17	Plastic Handle	R12014057948
18	Assy. Valve Cover	R50124072885
19	Assy. Cap Tube MLC 018CR MLC 020CR M5LC 020CR	R50024089931 R50024087058 R50024081904
20	Assy. 4 Way Valve MLC 018/020CR M5LC 020CR	R50054077222 R50059024520
21	Partition	R01014070603
Parts Not in Diagram		
	Capacitor, Fan Motor	R04029026759
	Capacitor, Compressor MLC 018/020CR M5LC 020CR	R04029026782 R04029026779

1) ALL SPECIFICATIONS ARE SUBJECT TO CHANGE BY THE MANUFACTURER WITHOUT PRIOR NOTICE

Model : MLC / M5LC 025CR, MLC 028CR

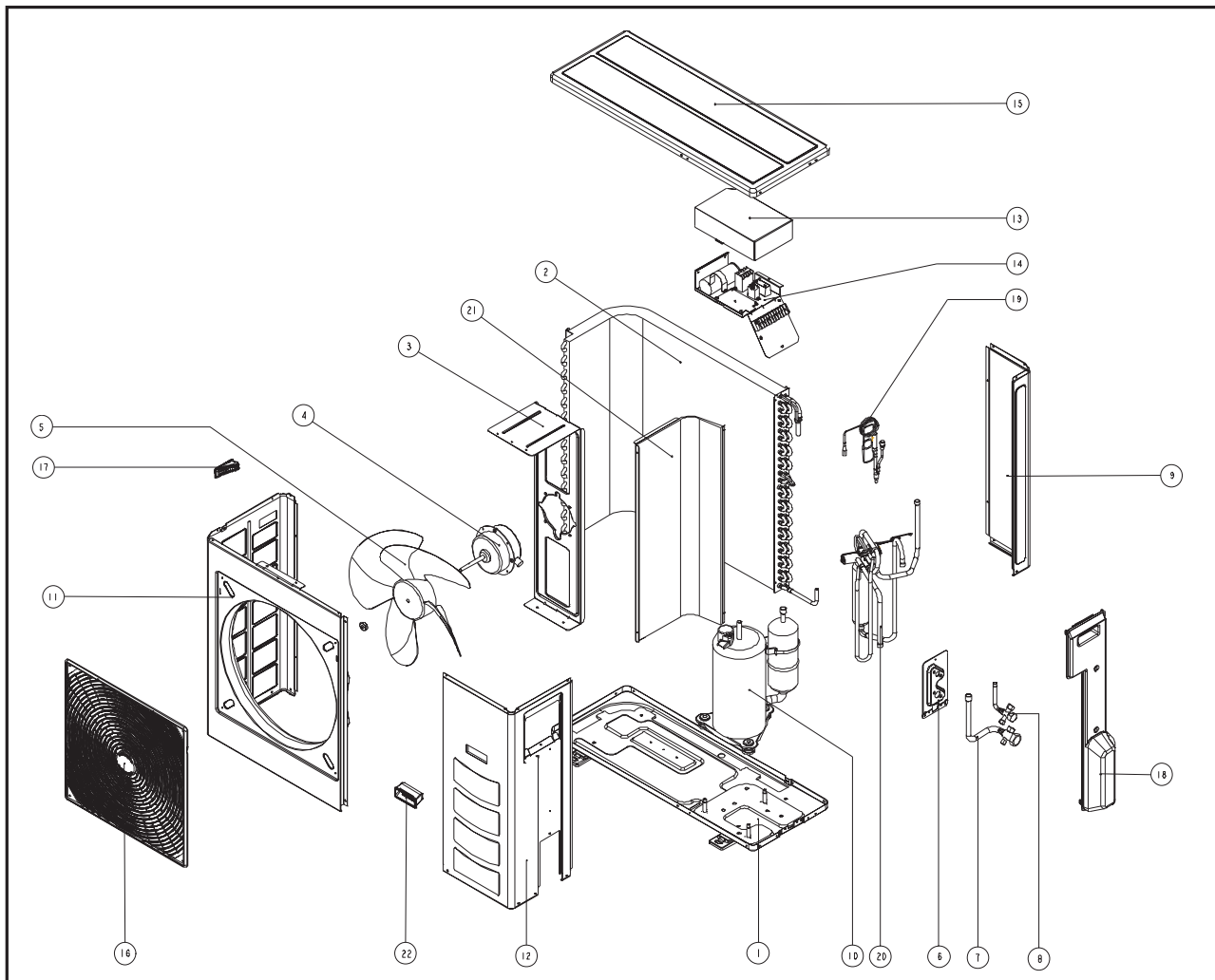

No	Description	Part No
1	Assy. Base Pan	R50014073884
2	Assy. Outdoor Coil MLC 025CR M5LC 025/028CR MLC 028CR	R50024088731 R50024075147 A50024082133
3	Motor Bracket	R01014070948
4	Fan Motor MLC 025CR M5LC 025CR MLC / M5LC 028CR	R03039028207 R03039023391 R03039024538
5	Fan Blade	R03019023393
6	Valve Bracket MLC 025/028CR M5LC 025CR M5LC 028CR	A50014073890 R50014078321 R50014080371
7	Assy. Flare Valve 3 Ways 5/8" MLC 025/028CR M5LC 025/028CR	R50054072863 R50059023336
8	MLC 025/028CR Assy. Flare Valve 3 Ways 3/8" M5LC 025CR Assy. Flare Valve 2 Ways 1/4" M5LC 028CR Assy. Flare Valve 3 Ways 3/8"	R50059022577 R50059023334 R50059024820
9	Back Panel, Right	R01014070950
10	Compressor MLC 025CR M5LC 025CR MLC 028CR M5LC 028CR	A04019027570 R04019021361 R04019012828 R04019020449

No	Description	Part No
11	Front Panel, Left	R01014070947
12	Service Panel	R01014070949
13	Terminal Cover Panel	R01014070838
14	Assy. Control Panel MLC / M5LC 025CR MLC 028CR M5LC 028CR	R50044086136 R50044086139 R50044086140
15	Top Panel	R01014070596
16	Assy. Front Grille	R50124072880
17	Plastic Handle, Side	R12014057948
18	Assy. Valve Cover	R50124073905
19	Assy. Cap Tube MLC 025CR M5LC 025CR MLC 028CR M5LC 028CR	R50024088789 R50024081899 A50024080186 R50024080312
20	Assy. 4 Way Valve MLC 025/028CR M5LC 025/028CR	R50054077222 R50059024520
21	Partition	R01014070951
22	Plastic Handle, Front	R12014070955

Parts Not in Diagram

	Capacitor, Fan Motor MLC / M5LC 025CR MLC / M5LC 028CR	R04029026759 R04029026966
	Capacitor, Compressor MLC / M5LC 025CR, MLC 028CR M5LC 028CR	R04029026779 R04029026778

1) ALL SPECIFICATIONS ARE SUBJECT TO CHANGE BY THE MANUFACTURER WITHOUT PRIOR NOTICE

Model : MLC 030 / 040C/CR

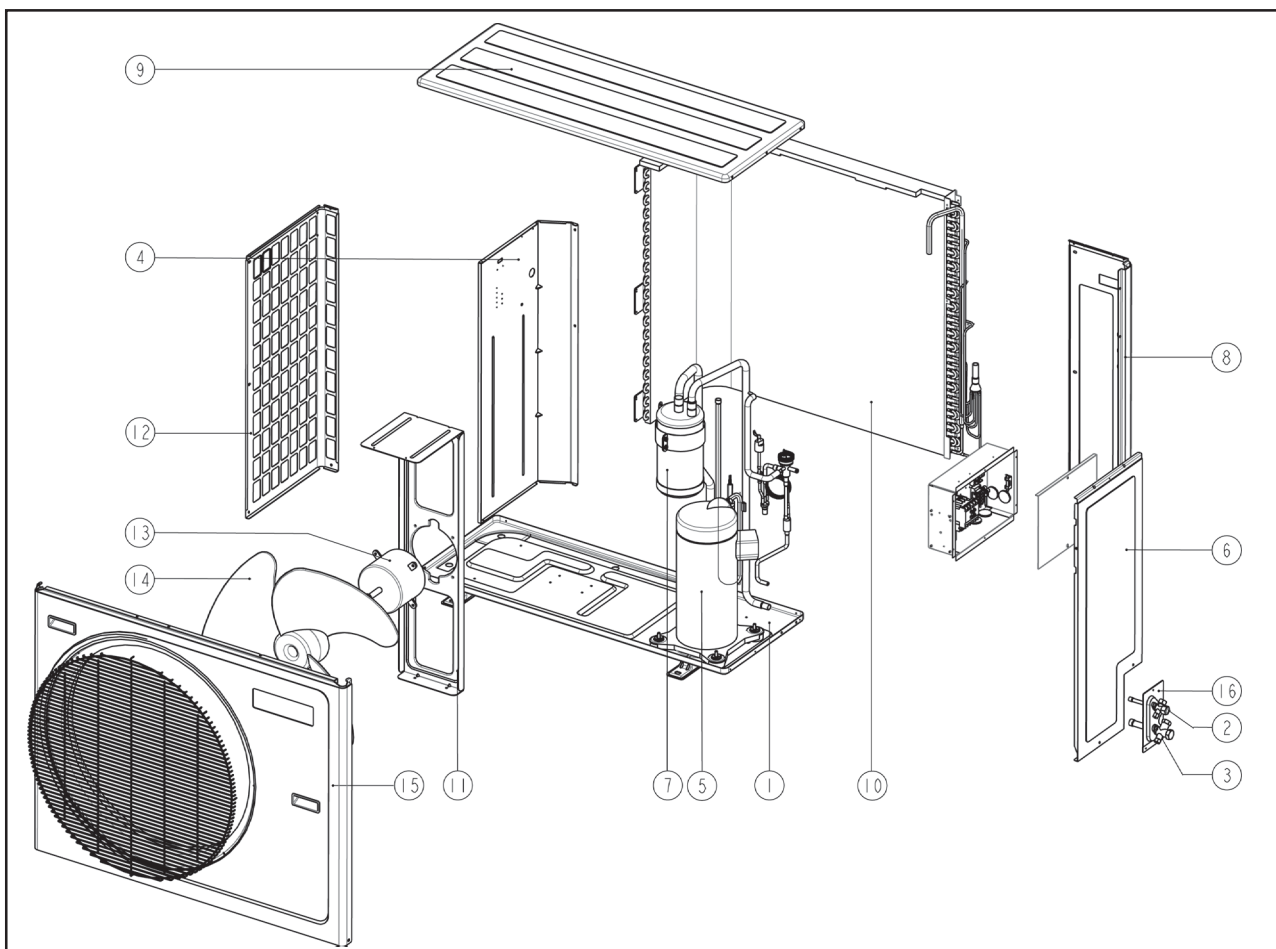

No	Description	Part No
1	Assy. Base Pan	R50014053238
2	Assy. Flare Valve 3/8" MLC 030/040C/CR	R50059000221
3	Assy. Flare Valve 5/8" MLC 030C/CR Assy. Flare Valve 3/4" MLC 040C/CR	R50059000071 R50059003794
4	Panel, Partition	R50014053277
5	Compressor MLC 030C/CR 220-240V/1PH/50Hz 380-415V/3PH/50Hz MLC 040C/CR 220-240V/1PH/50Hz 380-415V/3PH/50Hz	R50049013221 R50049019889 R50049018853 R50049013222
6	Service Panel	R01010029898
7	Accumulator MLC 030C/CR MLC 040C/CR	R02119025988 R02119002010
8	Back Panel, Right	R01014053233
9	Top Panel	R01011029900
10	Assy. Coil MLC 030C MLC 030CR MLC 040C MLC 040CR	A50024041851 A50024035282 A50024041850 A50024035281

No	Description	Part No
11	Bracket, Fan Motor	R01014053232
12	Side Panel, Left	R01010029899
13	Fan Motor	R03039004046
14	Fan Blade	R03013028160
15	Assy. Front Panel	R50014053236
16	Plate, Flare Valve	R01013034235
Parts Not in Diagram		
	Phase Sequencer	R04089017029
	High Pressure Switch	R04109015136
	Low Pressure Switch	R04109015125
	Assy. 4 Way Valve MLC 030CR MLC 040CR	R05029001991 R05019000863
	Capacitor, Fan Motor	R04029026761
	Capacitor, Compressor MLC 030C/CR MLC 040C/CR	R04029026779 R04029026782
	TXV	R05019020252
	Contactora	R04039018866

1) ALL SPECIFICATIONS ARE SUBJECT TO CHANGE BY THE MANUFACTURER WITHOUT PRIOR NOTICE

Model : MLC / M5LC 035C/CR

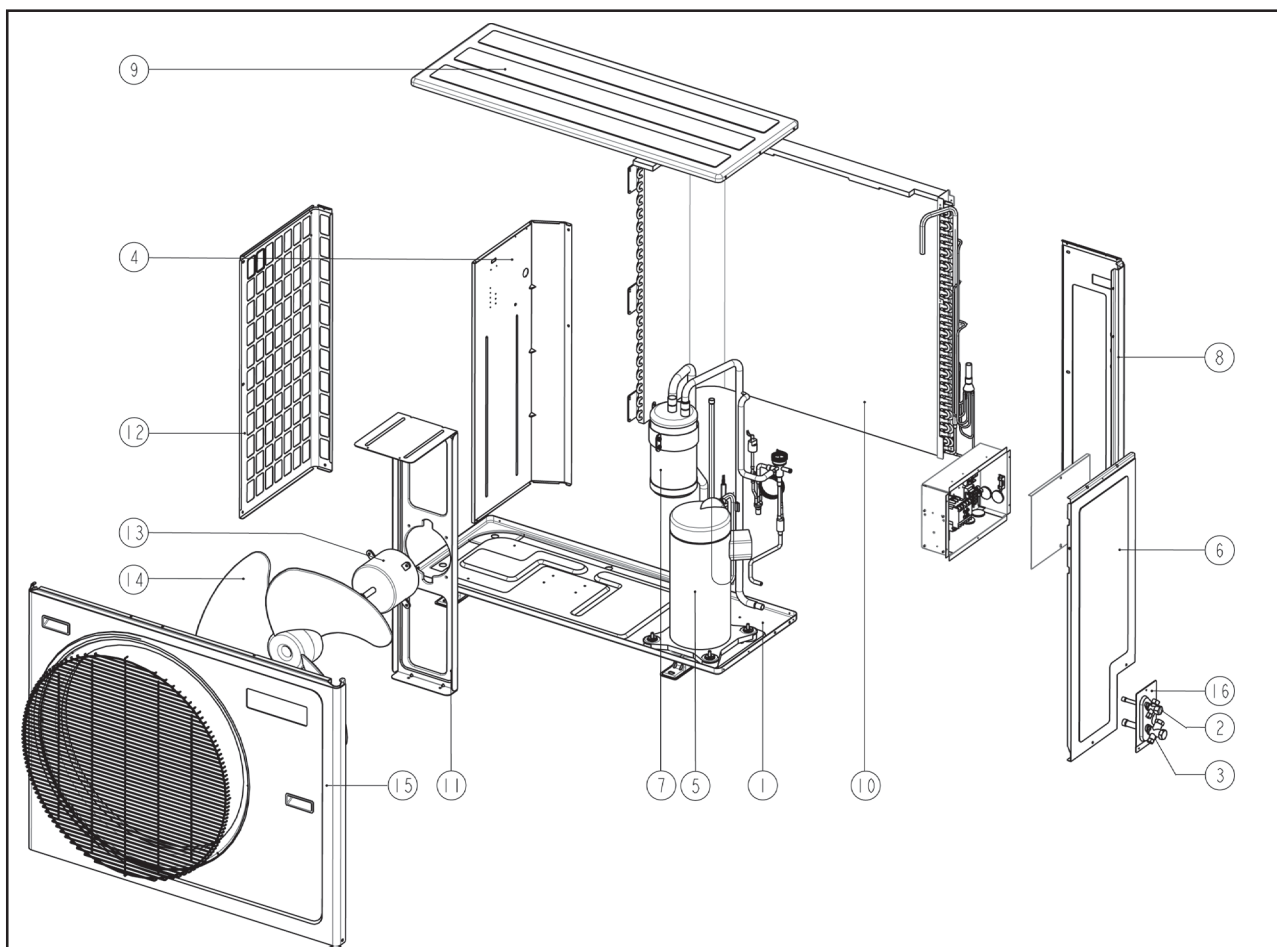

No	Description	Part No
1	Assy. Base Pan	R50014053238
2	Assy. Flare Valve 3/8" MLC 035C/CR	R50059000221
	M5LC 035C/CR	R50059017536
3	Assy. Flare Valve 3/4" MLC 035C/CR	R50059003794
	Assy. Flare Valve 5/8" M5LC 035C/CR	R50059020805
4	Panel, Partition	R50014053277
5	Compressor MLC 035C/CR	R50049013462
	M5LC 035C/CR	R50049025547
	220-240V/1PH/50Hz	R50049025336
	380-415V/3PH/50Hz	
6	Service Panel	R01010029898
7	Accumulator M5LC 035C/CR	R02119031841
8	Back Panel, Right	R01014053233
9	Top Panel	R01011029900
10	Assy. Coil M5LC 035C/CR	R50024082878
11	Bracket, Fan Motor	R01014053232
12	Side Panel, Left	R01010029899

No	Description	Part No
13	Fan Motor	R03039004046
14	Fan Blade	R03013028160
15	Assy. Front Panel	R50014053236
16	Plate, Flare Valve	R01013034235

Parts Not in Diagram

	Phase Sequencer	R04089017029
	High Pressure Switch MLC 035C/CR	R04109031314
	M5LC 035C/CR	R04104061879
	Low Pressure Switch MLC 035C	R04109015125
	M5LC 035C/CR	R04109015400
	Assy. 4 Way Valve MLC 035CR	R05019000863
	M5LC 035CR	R50024095671
	Capacitor, Fan Motor	R04029026761
	Contact	R04039018866
	Capacitor, Compressor MLC 035C/CR	R04029026761
	M5LC 035C / CR	R04029026761
	Assy. Cap. Tube M5LC 035C	R50024095667
	M5LC 035CR	R50024095666

1) ALL SPECIFICATIONS ARE SUBJECT TO CHANGE BY THE MANUFACTURER WITHOUT PRIOR NOTICE

Model : M5LC 040C/CR

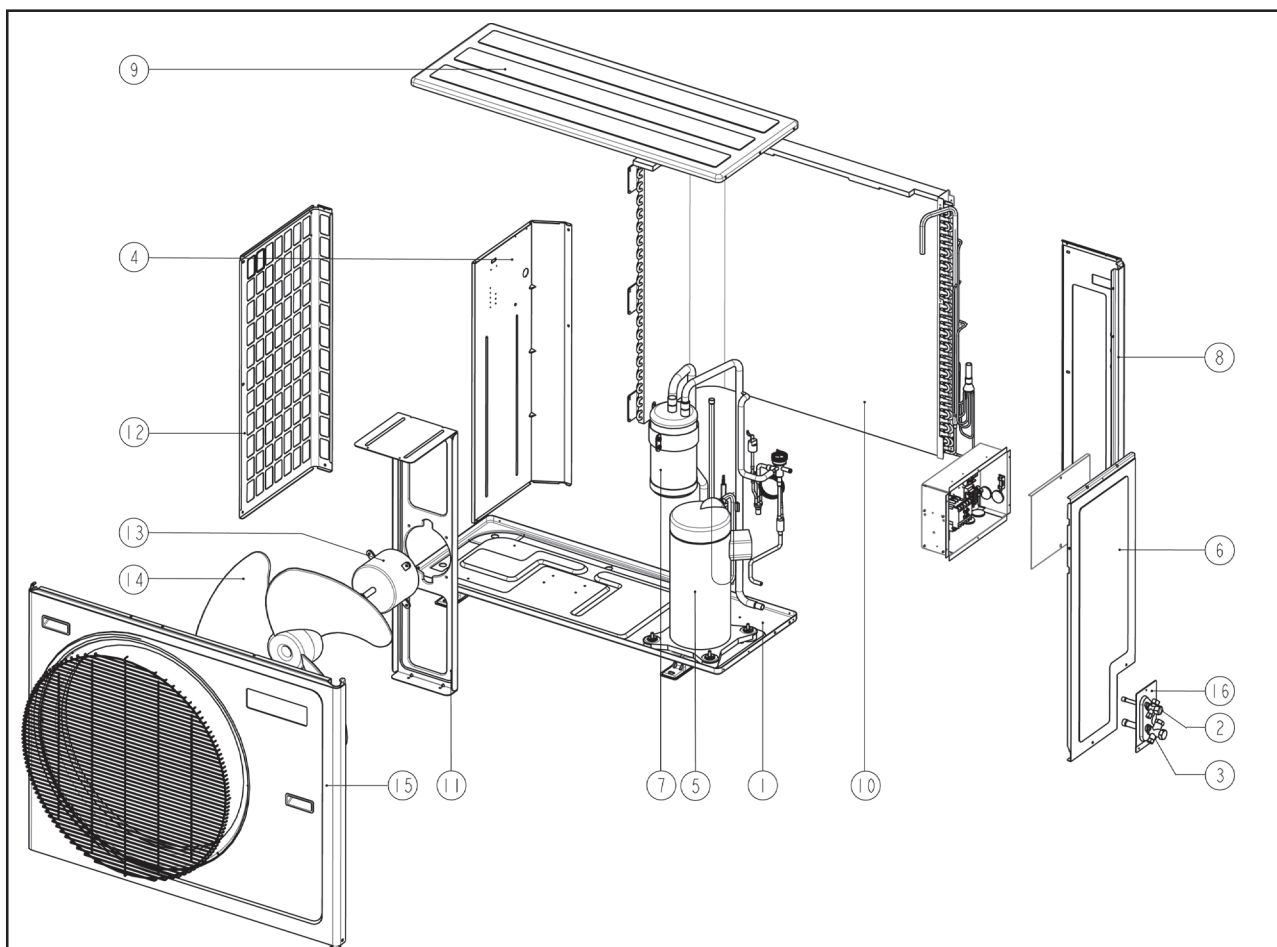

No	Description	Part No
1	Assy. Base Pan	R50014053238
2	Assy. Flare Valve 3/8"	R50059017536
3	Assy. Flare Valve 5/8"	R50059020805
4	Panel, Partition	R50014053277
5	Compressor M5LC 040C/CR 220-240V/1PH/50Hz 380-415V/3PH/50Hz	R50049028527 R50049025380
6	Service Panel	R01010029898
7	Accumulator	R02119024262
8	Back Panel, Right	R01014053233
9	Top Panel	R01011029900
10	Assy. Coil	R50024076551
11	Bracket, Fan Motor	R01014053232
12	Side Panel, Left	R01010029899

No	Description	Part No
13	Fan Motor	R03039004046
14	Fan Blade	R03013028160
15	Assy. Front Panel	R50014053236
16	Plate, Flare Valve	R01013034235

Parts Not in Diagram

17	Phase Sequencer (3 phase model only)	R04089017029
18	High Pressure Switch	R04104061879
19	Low Pressure Switch	R04109015400
20	Assy. 4 Way Valve	R05019019861
21	Capacitor, Fan Motor	R04029026761
22	Capacitor, Compressor	R04029026777
23	Assy. Cap. Tube -M5LC 040C -M5LC 040CR	R50024099890 R50024095119
24	Contacteur	R04039018866

1) ALL SPECIFICATIONS ARE SUBJECT TO CHANGE BY THE MANUFACTURER WITHOUT PRIOR NOTICE

Model : MLC 050 / 061C/CR

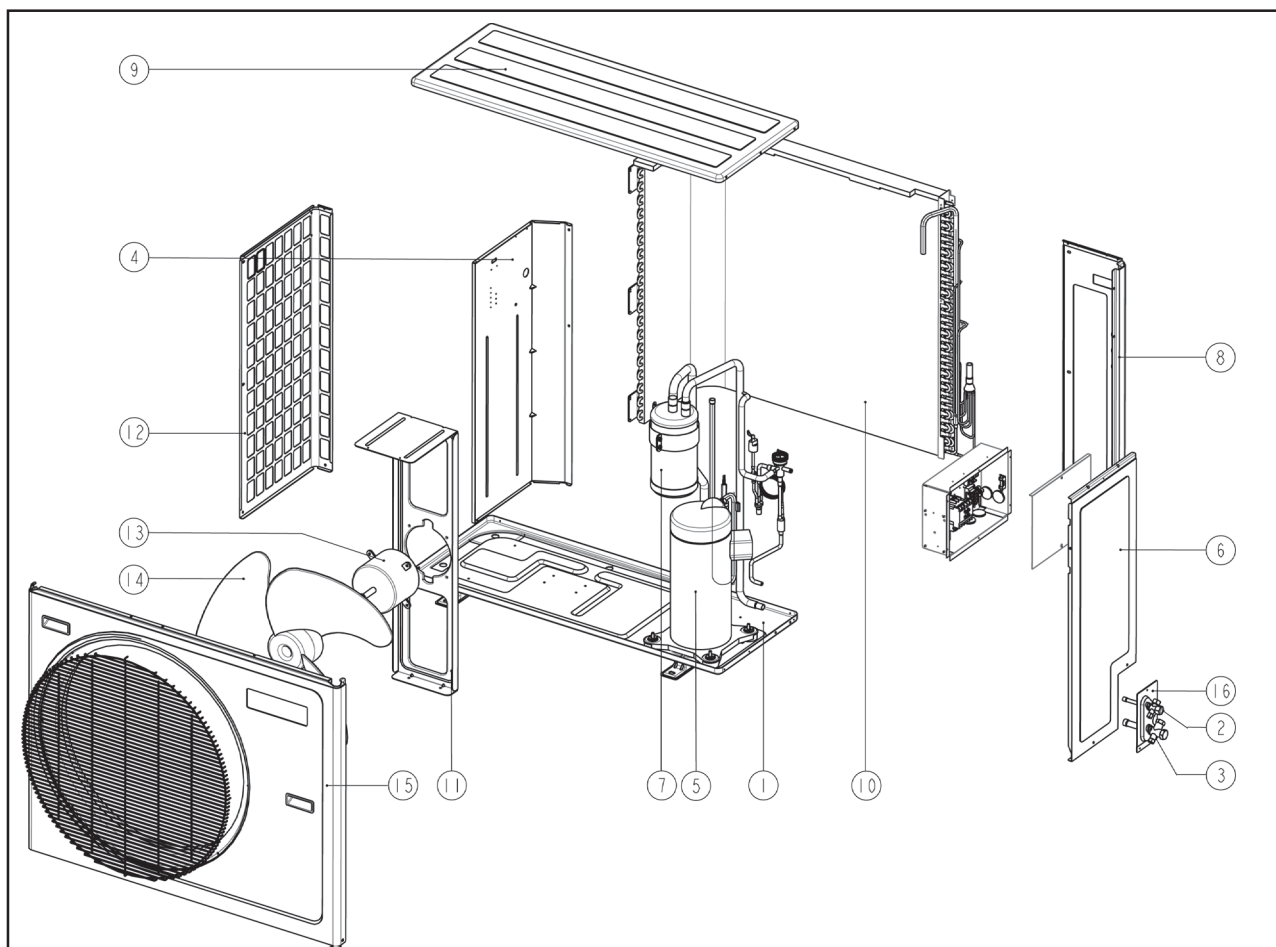

No	Description	Part No
1	Assy. Base Pan	R50014053238
2	MLC 050C/CR Assy. Flare Valve 3/8"	R50059000221
	MLC 061C/CR Assy. Flare Valve 1/2"	R50059000070
3	Assy. Flare Valve 3/4"	R50059003794
4	Panel, Partition MLC 050C/CR	R50014053277
	MLC 061C/CR	R50014051773
5	Compressor MLC 050C/CR	R50049013223
	MLC 061C/CR	R50049004675
6	Service Panel	R01010029898
7	Accumulator	R02119002010
8	Back Panel, Right	R01014053233
9	Top Panel	R01011029900
10	Assy. Coil MLC 050C	A50024041849
	MLC 050CR	A50024035281
	MLC 061C	A50024051761
	MLC 061CR	A50024052569

No	Description	Part No
11	Bracket, Fan Motor MLC 050C/CR	R01014053232
	MLC 061C/CR	R01014051775
12	Side Panel, Left	R01010029899
13	Fan Motor MLC 050C/CR	R03039004046
	MLC 061C/CR	R03039016103
14	Fan Blade	R03013028160
15	Assy. Front Panel MLC 050C/CR	R50014053236
	MLC 061C/CR	R01014051758
16	Plate, Flare Valve	R01013029901

Parts Not in Diagram

	Phase Sequencer	R04089017029
	High Pressure Switch	R04109015136
	Low Pressure Switch	R04109015125
	Assy. 4 Way Valve	R05019000863
	Capacitor, Fan Motor MLC 050C/CR	R04029026761
	MLC 061C/CR	R04029026767
	TXV MLC 050CR	R05019002020
	Contactora	R04039018866

1) ALL SPECIFICATIONS ARE SUBJECT TO CHANGE BY THE MANUFACTURER WITHOUT PRIOR NOTICE

Model : M5LC 050 / 061C/CR

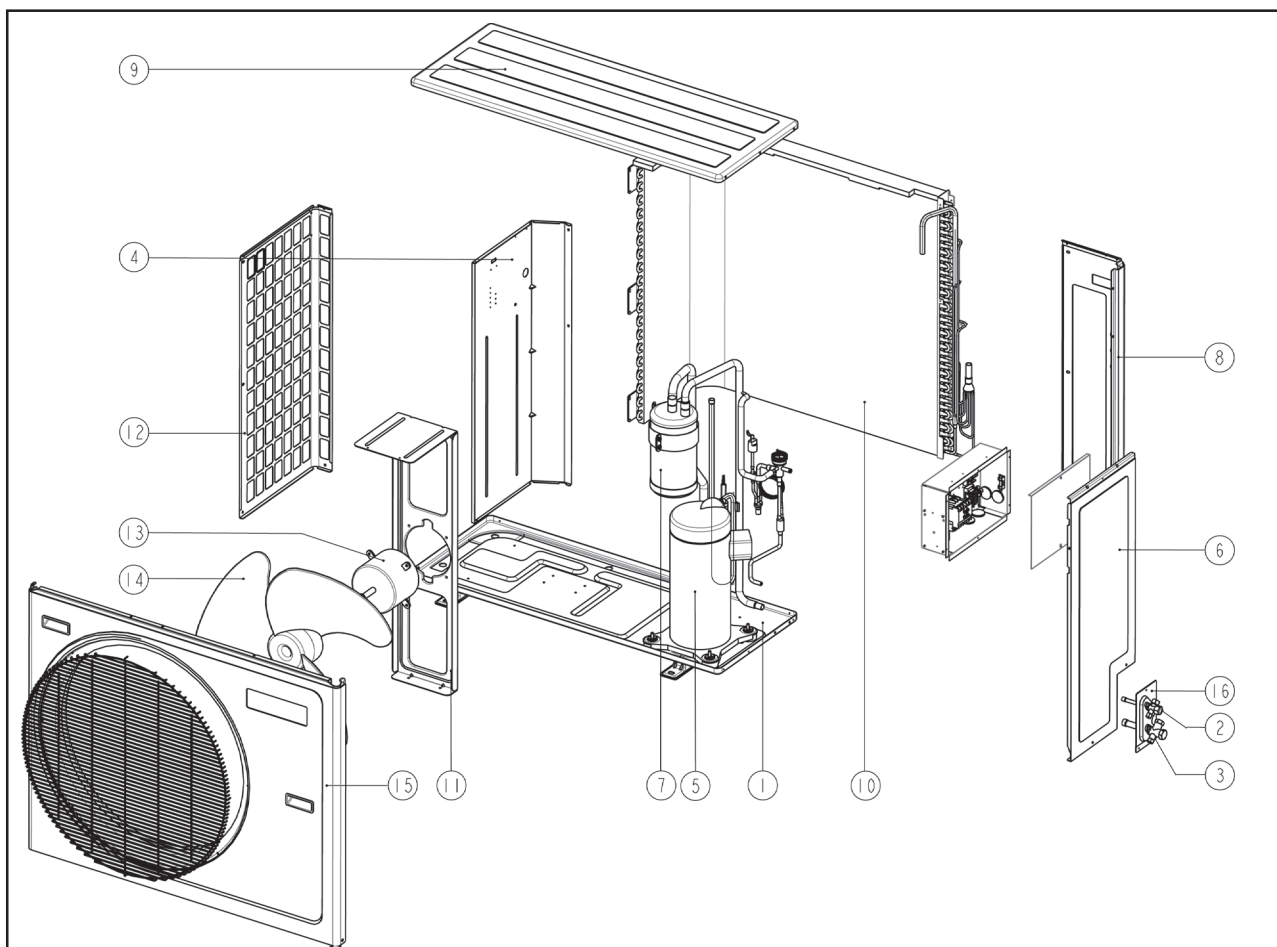

No	Description	Part No
1	Assy. Base Pan	R50014053238
2	Assy. Flare Valve 3/8"	R50059017536
3	M5LC 050C/CR Assy. Flare Valve 5/8" M5LC 061C/CR Assy. Flare Valve 3/4"	R50059020805 R50059022642
4	Panel, Partition M5LC 050C/CR M5LC 061C/CR	R50014053277 R50014051773
5	Compressor M5LC 050C/CR M5LC 061C/CR	R50049022878 R50049025385
6	Service Panel	R01010029898
7	Accumulator	R02119031841
8	Back Panel, Right	R01014053233
9	Top Panel	R01011029900
10	Assy. Coil M5LC 050C/CR M5LC 061C/CR	R50024084456 R50024081276
11	Bracket, Fan Motor M5LC 050C/CR M5LC 061C/CR	R01014053232 R01014051775

No	Description	Part No
12	Side Panel, Left	R01010029899
13	Fan Motor M5LC 050C/CR M5LC 061C/CR	R03039016103 R03039006814
14	Fan Blade	R03013028160
15	Assy. Front Panel M5LC 050C/CR M5LC 061C/CR	R50014053236 R01014051758
16	Plate, Flare Valve	R01013034235
Parts Not in Diagram		
	Phase Sequencer	R04089017029
	High Pressure Switch	R04104061879
	Low Pressure Switch	R04109015400
	Assy. 4 Way Valve	R50024098532
	Capacitor, Fan Motor	R04029026767
	Contactora	R04039018866
	Assy. Cap. Tube M5LC 050C M5LC 050CR M5LC 061C M5LC 061CR	R50024099357 R50024099359 R50024095779 R50024095780

1) ALL SPECIFICATIONS ARE SUBJECT TO CHANGE BY THE MANUFACTURER WITHOUT PRIOR NOTICE

Products manufactured in an ISO certified facility.
This document contains the most current product information as of this printing. For the most up-to-date product information, please go to www.mcquay.com.



© 2008 McQuay International

+1 (800) 432-1342

www.mcquay.com



Большая библиотека технической документации
<https://splitsystema48.ru/instrukcii-po-ekspluatácii-kondicionerov.html>
каталоги, инструкции, сервисные мануалы, схемы.